



# Installation and Owner's Manual

**Air-cooled Automatic  
Standby Generators**

**Models:**

**04758-0 (6 kW NG, 7 kW LP)**

**04759-0 (12 kW NG, 12 kW LP)**

**04760-0 (13 kW NG, 15 kW LP)**

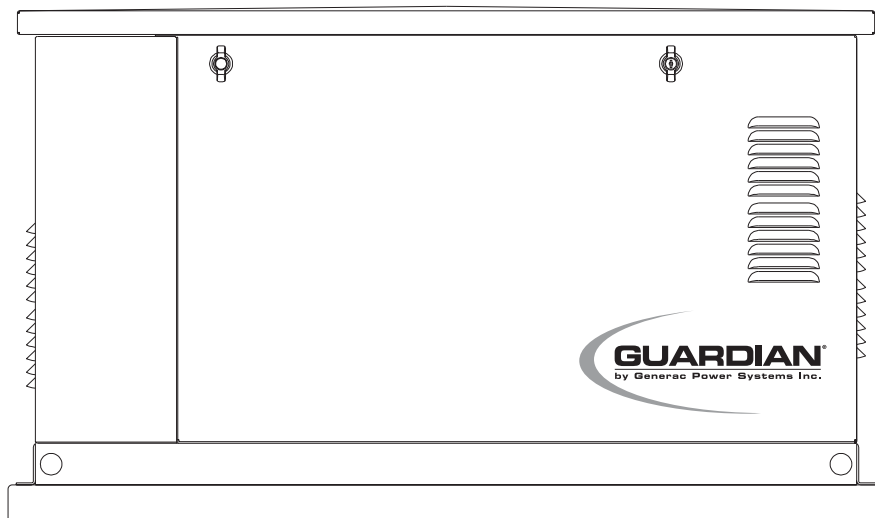

**Not intended for use as Primary Power in place of utility  
or in life-support applications.**



**—▲ DANGER ▲—**

**DEADLY EXHAUST FUMES. OUTDOOR INSTALLATION ONLY!!**

## INTRODUCTION

Thank you for purchasing this model by Generac Power Systems Inc.. This model is a compact, high performance, air-cooled, engine-driven generator designed to automatically supply electrical power to operate critical loads during a utility power failure.

This unit is factory installed in an all-weather, metal enclosure that is intended exclusively for outdoor installation. This generator will operate using either vapor withdrawn liquid propane (LP) or natural gas (NG).

**This unit meets the 1998 and later California emissions regulations. To ensure that your engine continues to meet these regulations, refer to the following information and instructions in this owner's manual.**

### ◆ ENGINE EMISSION COMPLIANCE PERIOD

For nonhandheld engines: The Emissions Compliance Period referred to on the Emissions Compliance label indicates the number of operating hours for which the engine has been shown to meet federal emission requirements.

For engines less than 225 cc displacement, Category C = 125 hours, B = 250 hours, and A = 500 hours.

For engines 225 cc or more, Category C = 250 hours, B = 500 hours, and A = 1000 hours.

### ◆ READ THIS MANUAL THOROUGHLY

If you do not understand any portion of this manual, contact Generac or your nearest Generac Authorized Dealer for starting, operating and servicing procedures.

Throughout this publication, and on tags and decals affixed to the generator, DANGER, WARNING, CAUTION and NOTE blocks are used to alert you to special instructions about a particular operation that may be hazardous if performed incorrectly or carelessly. Observe them carefully. Their definitions are as follows:



**After this heading, you can read instructions that, if not strictly complied with, will result in serious personal injury, including death, in addition to property damage.**



**After this heading, you can read instructions that, if not strictly complied with, may result in serious personal injury or property damage.**



**After this heading, you can read instructions that, if not strictly complied with, could result in damage to equipment and/or property.**

#### NOTE:

**After this heading, you can read explanatory statements that require special emphasis.**

These safety warnings cannot eliminate the hazards that they indicate. Common sense and strict compliance with the special instructions while performing the service are essential to preventing accidents.

Four commonly used safety symbols accompany the DANGER, WARNING and CAUTION blocks. The type of information each indicates follows:

 This symbol points out important safety information that, if not followed, could endanger personal safety and/or property of you and others.

 This symbol points out potential explosion hazard.

 This symbol points out potential fire hazard.

 This symbol points out potential electrical shock hazard.

The operator is responsible for proper and safe use of the equipment. We strongly recommend that the operator read this *Owner's Manual* and thoroughly understand all instructions before using this equipment. We also strongly recommend instructing other users to properly start and operate the unit. This prepares them if they need to operate the equipment in an emergency.

### ◆ CONTENTS

This manual contains pertinent owner's information, including warranty, electrical diagrams, exploded views and lists of repair parts, for three different Guardian models:

- 04758-0 – 6 kW NG, 7 kW LP, single-cylinder GH-410 Engine
- 04759-0 – 12 kW NG, 12 kW LP, V-twin GT-990 Engine
- 04760-0 – 13 kW NG, 15 kW LP, V-twin GT-990 Engine

### ◆ OPERATION AND MAINTENANCE

It is the operator's responsibility to perform all safety checks, to make sure that all maintenance for safe operation is performed promptly, and to have the equipment checked periodically by a Generac Authorized Dealer. Normal maintenance service and replacement of parts are the responsibility of the owner/operator and, as such, are not considered defects in materials or workmanship within the terms of the warranty. Individual operating habits and usage contribute to the need for maintenance service.

Proper maintenance and care of your generator ensure a minimum number of problems and keep operating expenses at a minimum. See your Generac Authorized Dealer for service aids and accessories.

### ◆ HOW TO OBTAIN SERVICE

When your generator requires servicing or repairs, simply contact a Generac Authorized Dealer for assistance. Service technicians are factory-trained and are capable of handling all of your service needs.

When contacting a Generac Authorized Dealer or the factory about parts and service, always supply the complete model number and serial number of your unit as given on its data decal, which is located on your generator. See Figure 1.1 or Figure 1.2 in Section 1.4 (Page 5) for decal location.

Model No. \_\_\_\_\_ Serial No. \_\_\_\_\_

#### AUTHORIZED DEALER LOCATION

To locate the GENERAC AUTHORIZED DEALER nearest you, please call this number:

**1-800-333-1322**

DEALER LOCATION INFORMATION  
CAN BE OBTAINED AT THIS NUMBER.

**Introduction .....Inside Front Cover**

Read This Manual Thoroughly .....IFC  
 Contents .....IFC  
 Operation and Maintenance .....IFC  
 How to Obtain Service .....IFC  
 Authorized Dealer Locator Number .....IFC

**Safety Rules .....2**

Standards Index .....3

**Section 1 – General Information .....4**

1.1 Unpacking/Inspection .....4  
 1.2 Protection Systems .....4  
 1.3 System Set LED .....4  
 1.4 Your Generator .....5  
 1.5 Specifications .....6  
     1.5.1 Generator .....6  
     1.5.2 Engine .....6  
 1.6 Fuel Requirements and Recommendations....7  
 1.7 Fuel Consumption .....7  
 1.8 Reconfiguring the Fuel System .....7  
     1.8.1 7 kW, 410CC .....7  
     1.8.2 12 kW and 15 kW, 990cc Engines .....7  
 1.9 Location .....8  
     1.9.1 Generator .....8  
     1.9.2 Transfer Switch .....8  
 1.10 Battery Installation .....9  
 1.11 The Battery .....9

**Section 2 – Post Installation Start-up and Adjustments .....10**

2.1 Before Initial Start-up .....10  
 2.2 Check Transfer Switch Operation .....10  
 2.3 Electrical Checks .....10  
 2.4 Generator Tests Under Load .....11  
 2.5 Checking Automatic Operation .....11  
 2.6 Adjusting the Regulator (Natural Gas Only) ..12  
 2.7 Engine Governor Adjustment .....12  
     2.7.1 7 kW Units .....12  
     2.7.2 12 kW and 15 kW Units .....13  
     2.7.3 Additional Corrosion Protection .....13  
 2.8 Voltage Regulator Adjustment .....13

**Section 3 – Operation .....13**

3.1 Break-in Procedure .....13  
 3.2 Using the Auto/Off/Manual Switch .....14  
     3.2.1 “Auto” Position .....14

3.2.2 “Off” Position .....14  
 3.2.3 “Manual” Position .....14  
 3.3 Automatic Transfer Operation .....14  
 3.4 Sequence of Automatic Operation .....14  
 3.5 Manual Transfer Operation .....15  
     3.5.1 Transfer to Generator Power Source .....15  
     3.5.2 Transfer Back to Utility Power Source .....15  
 3.6 Setting the Exercise Timer .....16  
 3.7 Protection Systems .....16  
     3.7.1 Low Oil Pressure Switch .....16  
     3.7.2 High Temperature Switch .....16  
     3.7.3 Overcrank .....16  
     3.7.4 Overspeed .....16

**Section 4 – Maintenance .....17**

4.1 Fuse .....17  
 4.2 Checking the Engine Oil Level .....17  
 4.3 Changing the Engine Oil .....17  
     4.3.1 Engine Oil Recommendations .....17  
     4.3.2 Oil Change Procedure .....18  
 4.4 Changing the Oil Filter .....18  
 4.5 Changing the Engine Air Cleaner .....18  
     4.5.1 7 kW, 12 kW and 15 kW Generators .....18  
 4.6 Spark Plug(s) .....19  
 4.7 Battery Maintenance .....19  
 4.8 Adjusting Valve Clearance .....20  
 4.9 Cooling System .....20  
 4.10 Attention After Submersion .....21  
 4.11 Corrosion Protection .....21  
 4.12 Out of Service Procedure .....21  
     4.12.1 Removal From Service .....21  
     4.12.2 Return to Service .....21  
 4.13 Service Schedule .....22

**Section 5 – Troubleshooting .....23**

5.1 Troubleshooting Guide .....23

**Section 6 – Electrical Data .....24**

**Section 7 – Exploded Views and Parts Lists .....32**

**Section 8 – Mounting Dimensions .....50**

**Section 9 – Notes .....51**

**Section 10 – Warranty .....52**



## IMPORTANT SAFETY INSTRUCTIONS

Guardian Air-cooled 7 kW, 12 kW and 15 kW Generators

**SAVE THESE INSTRUCTIONS** – The manufacturer suggests that these rules for safe operation be copied and posted near the unit's installation site. Safety should be stressed to all operators and potential operators of this equipment.



### WARNING:



The engine exhaust from this product contains chemicals known to the state of California to cause cancer, birth defects or other reproductive harm.



### WARNING:



This product contains or emits chemicals known to the state of California to cause cancer, birth defects or other reproductive harm.

Study these SAFETY RULES carefully before installing, operating or servicing this equipment. Become familiar with this *Owner's Manual* and with the unit. The generator can operate safely, efficiently and reliably only if it is properly installed, operated and maintained. Many accidents are caused by failing to follow simple and fundamental rules or precautions.

Generac cannot possibly anticipate every possible circumstance that might involve a hazard. The warnings in this manual, and on tags and decals affixed to the unit are, therefore, not all-inclusive. If you use a procedure, work method or operating technique Generac does not specifically recommend, you must satisfy yourself that it is safe for you and others. You also must make sure the procedure, work method or operating technique that you choose does not render the generator unsafe.



### DANGER



Despite the safe design of this generator, operating this equipment imprudently, neglecting its maintenance or being careless can cause possible injury or death. Permit only responsible and capable persons to operate or maintain this equipment.



Potentially lethal voltages are generated by these machines. Ensure all steps are taken to render the machine safe before attempting to work on the generator.



Parts of the generator are rotating and/or hot during operation. Exercise care near running generators.



### GENERAL HAZARDS



- For safety reasons, Generac recommends that the installation, initial start-up and maintenance of this equipment is carried out by a Generac Authorized Dealer.
- The engine exhaust fumes contain carbon monoxide, which can be DEADLY. This dangerous gas, if breathed in sufficient concentrations, can cause unconsciousness or even death. This exhaust system must be installed properly, in strict compliance with applicable codes and standards. Following installation, you must do nothing that might render the system unsafe or in noncompliance with such codes and standards.
- Keep hands, feet, clothing, etc., away from drive belts, fans, and other moving or hot parts. Never remove any drive belt or fan guard while the unit is operating.
- Adequate, unobstructed flow of cooling and ventilating air is critical to correct generator operation. Do not alter the installation or permit even partial blockage of ventilation provisions, as this can seriously affect safe operation of the generator. The generator MUST be installed outdoors.
- When working on this equipment, remain alert at all times. Never work on the equipment when you are physically or mentally fatigued.
- Inspect the generator regularly, and contact your nearest Generac Authorized Dealer for parts needing repair or replacement.
- Before performing any maintenance on the generator, disconnect its battery cables to prevent accidental start up. Disconnect the cable from the battery post indicated by a NEGATIVE, NEG or (-) first. Reconnect that cable last.
- Never use the generator or any of its parts as a step. Stepping on the unit can stress and break parts, and may result in dangerous operating conditions from leaking exhaust gases, fuel leakage, oil leakage, etc.



 **ELECTRICAL HAZARDS** 

- All generators covered by this manual produce dangerous electrical voltages and can cause fatal electrical shock. Utility power delivers extremely high and dangerous voltages to the transfer switch as does the standby generator when it is in operation. Avoid contact with bare wires, terminals, connections, etc., while the unit is running. Ensure all appropriate covers, guards and barriers are in place before operating the generator. If you must work around an operating unit, stand on an insulated, dry surface to reduce shock hazard.
- Do not handle any kind of electrical device while standing in water, while barefoot, or while hands or feet are wet. **DANGEROUS ELECTRICAL SHOCK MAY RESULT.**
- The National Electrical Code (NEC) requires the frame and external electrically conductive parts of the generator to be connected to an approved earth ground. Local electrical codes also may require proper grounding of the generator electrical system.
- After installing this home standby electrical system, the generator may crank and start at any time without warning. When this occurs, load circuits are transferred to the STANDBY (generator) power source. To prevent possible injury if such a start and transfer occur, always set the generator's Auto/Off/Manual switch to its OFF position before working on equipment and remove the 5A and 15A fuses from the generator control panel.
- In case of accident caused by electric shock, immediately shut down the source of electrical power. If this is not possible, attempt to free the victim from the live conductor. **AVOID DIRECT CONTACT WITH THE VICTIM.** Use a nonconducting implement, such as a rope or board, to free the victim from the live conductor. If the victim is unconscious, apply first aid and get immediate medical help.
- Never wear jewelry when working on this equipment. Jewelry can conduct electricity resulting in electric shock, or may get caught in moving components causing injury.

 **FIRE HAZARDS** 

- For fire safety, the generator must be installed and maintained properly. Installation always must comply with applicable codes, standards, laws and regulations. Adhere strictly to local, state and national electrical and building codes. Comply with regulations the Occupational Safety and Health Administration (OSHA) has established. Also, ensure that the generator is installed in accordance with the manufacturer's instructions and recommendations. Following proper installation, do nothing that might alter a safe installation and render the unit in noncompliance with the aforementioned codes, standards, laws and regulations.

- Keep a fire extinguisher near the generator at all times. Extinguishers rated "ABC" by the National Fire Protection Association are appropriate for use on the standby electric system. Keep the extinguisher properly charged and be familiar with its use. If you have any question pertaining to fire extinguishers, consult your local fire department.

 **EXPLOSION HAZARDS** 

- Do not smoke around the generator. Wipe up any fuel or oil spills immediately. Ensure that no combustible materials are left in the generator compartment, or on or near the generator, as FIRE or EXPLOSION may result. Keep the area surrounding the generator clean and free from debris.
- Gaseous fluids such as natural gas and liquid propane (LP) gas are extremely EXPLOSIVE. Install the fuel supply system according to applicable fuel-gas codes. Before placing the home standby electric system into service, fuel system lines must be properly purged and leak tested according to applicable code. After installation, you must inspect the fuel system periodically for leaks. No leakage is permitted.

**◆ STANDARDS INDEX**

In the absence of pertinent standards, codes, regulations and laws, the published information listed below may be used as installation guide for this equipment.

1. NFPA No. 37, STATIONARY COMBUSTION ENGINES AND GAS TURBINES, available from the National Fire Protection Association, 470 Atlantic Avenue, Boston, MA 02210.
2. NFPA No. 76A, ESSENTIAL ELECTRICAL SYSTEMS FOR HEALTH CARE FACILITIES, available same as Item 1.
3. NFPA No. 54, NATIONAL FUEL GAS CODE, available same as Item 1.
4. NFPA No. 58, AMERICAN NATIONAL STANDARD FOR STORAGE AND HANDLING OF LIQUEFIED PETROLEUM GAS, available same as Item 1.
5. NFPA No. 70, NFPA HANDBOOK OF NATIONAL ELECTRIC CODE, available same as Item 1.
6. Article X, NATIONAL BUILDING CODE, available from the American Insurance Association, 85 John Street, New York, N.Y. 10038.
7. AGRICULTURAL WIRING HANDBOOK, available from the Food and Energy Council, 909 University Avenue, Columbia, MO 65201.
8. ASAE EP-3634, INSTALLATION AND MAINTENANCE OF FARM STANDBY ELECTRICAL SYSTEMS, available from the American Society of Agricultural Engineers, 2950 Niles Road, St. Joseph, MI 49085.
9. NFPA No. 30, FLAMMABLE AND COMBUSTIBLE LIQUIDS CODE, available same as Item 1.

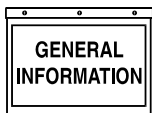

## Section 1 – General Information

### Guardian Air-cooled 7 kW, 12 kW and 15 kW Generators



- ⚠️ **Only qualified electricians or contractors should attempt such installations, which must comply strictly with applicable codes, standards and regulations.**

### 1.1 UNPACKING/INSPECTION

After unpacking, carefully inspect the contents for damage.

- This standby generator set has been factory supplied with a weather protective enclosure that is intended for **outdoor installation only**.



- ⚠️ **If this generator is used to power electrical load circuits normally powered by a utility power source, you are required by code to install a transfer switch. The transfer switch must effectively isolate the electrical system from the utility distribution system when the generator is operating (NEC 700, 701 and 702). Failure to isolate an electrical system by such means will result in damage to the generator and also may result in injury or death to utility power workers due to backfeed of electrical energy.**

If any loss or damage is noted at time of delivery, have the person(s) making the delivery note all damage on the freight bill or affix his or her signature under the consignor's memo of loss or damage.

If you note loss or damage after delivery, separate the damaged materials and contact the carrier for claim procedures.

“Concealed damage” is understood to mean damage to the contents of a package that is not in evidence at the time of delivery, but is discovered later.

### 1.2 PROTECTION SYSTEMS

Unlike an automobile engine, the generator may have to run for long periods of time with no operator present to monitor engine conditions. For that reason, the engine is equipped with the following systems that protect it against potentially damaging conditions:

1. Low Oil Pressure Sensor
2. High Temperature Sensor
3. Overcrank
4. Overspeed

There are LED readouts on the control panel to notify you that one of these faults has occurred. There is also a “System Set” LED that is described below.

### 1.3 SYSTEM SET LED

The “System Set” LED is lit when all of the following conditions are true:

1. The Auto/Off/Manual switch is set to the AUTO position.
2. The utility voltage being supplied to the unit is being sensed by the Control PCB. If the utility sense voltage is not connected to the unit or if it is below 168 volts AC, then the system set light will flash rapidly. This indicates that if the Auto/Off/Manual switch is placed in the Auto position, the generator will start.
3. The “Not In Auto” dip switch is set to the OFF position on the control board.
4. No alarms are present, for example, low oil pressure, high temperature, etc.

## 1.4 YOUR GENERATOR

Figure 1.1 – 7 kW, Single Cylinder GH-410 Engine

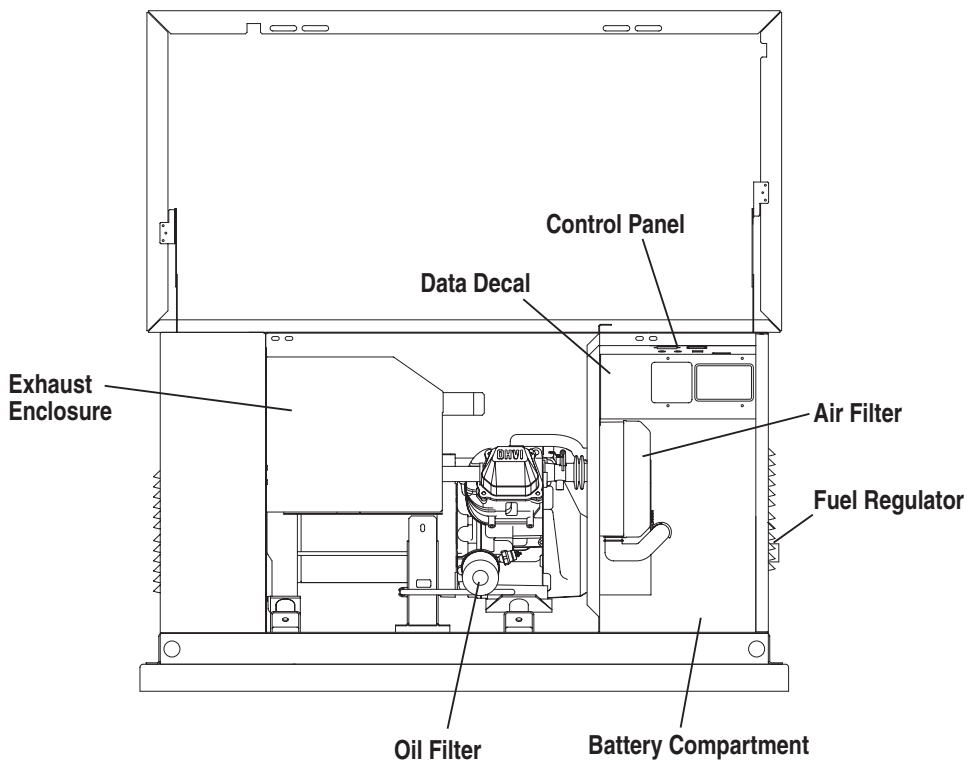
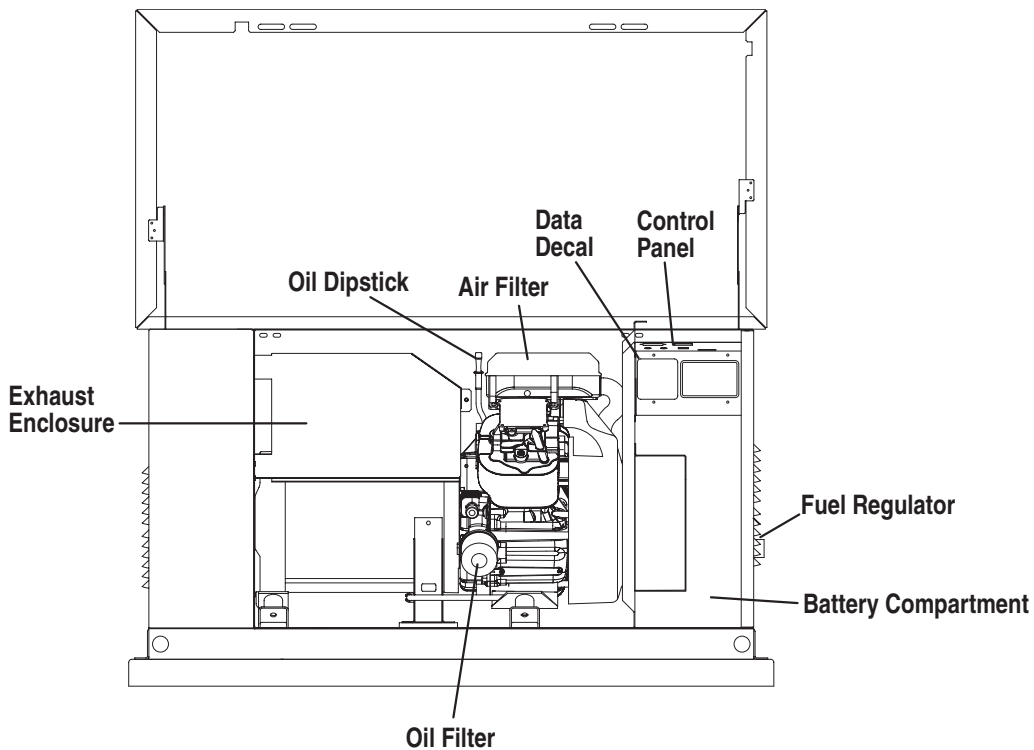
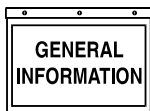

Figure 1.2 – 12 kW/15 kW, V-twin GT-990 Engine





## Section 1 – General Information

### Guardian Air-cooled 7 kW, 12 kW and 15 kW Generators

## 1.5 SPECIFICATIONS

### ◆ 1.5.1 GENERATOR

	<b>Model 04758</b>	<b>Model 04759</b>	<b>Model 04760</b>
Rated Max. Continuous Power Capacity (Watts*)	6,000 NG/7,000 LP	12,000 NG/12,000 LP	13,000 NG/15,000 LP+
Rated Voltage	120/240	120/240	120/240
Rated Max. Continuous Load Current (Amps)			
120 Volts +	50.0 NG/58.3 LP	100.0 NG/100.0 LP	108.3 NG/125.0 LP
240 Volts	25.0 NG/29.2 LP	50.0 NG/50.0 LP	54.2 NG/62.5 LP
Main Line Circuit Breaker	30 Amp	50 Amp	70 Amp
Phase	1	1	1
Number of Rotor Poles	2	2	2
Rated AC Frequency	60 Hz	60 Hz	60 Hz
Power Factor	1	1	1
Recommended Air Filter	Generac Part # C8127	Generac Part # C8127	Generac Part # C8127
Battery Requirement	Group 26/26R 12 Volts and 350 Cold-cranking Amperes Minimum	Group 26/26R 12 Volts and 550 Cold-cranking Amperes Minimum	Group 26/26R 12 Volts and 550 Cold-cranking Amperes Minimum
Weight	452 Pounds	470 Pounds	487 Pounds
Output Sound Level @ 23 ft (7m) at full load	68 db (A)	70.5db (A)	71.5 db (A)
Normal Operating Range	-20°F (-28.8°C) to 104°F (40°C)		

\* Maximum wattage and current are subject to and limited by such factors as fuel Btu content, ambient temperature, altitude, engine power and condition, etc. Maximum power decreases about 3.5 percent for each 1,000 feet above sea level; and also will decrease about 1 percent for each 6° C (10° F) above 16° C (60° F).

+ Total current in TWO separate circuits. Current in each circuit must not exceed the value stated for 240V.

### ◆ 1.5.2 ENGINE

	<b>Model 04758</b>	<b>Model 04759</b>	<b>Model 04760</b>
Type of Engine	GH-410	GT-990	GT-990
Number of Cylinders	1	2	2
Rated Horsepower	14.5 @ 3,600 rpm	30 @ 3,600 rpm	30 @ 3,600 rpm
Displacement	410cc	992cc	992cc
Cylinder Block	Aluminum w/Cast Iron Sleeve	Aluminum w/Cast Iron Sleeve	Aluminum w/Cast Iron Sleeve
Valve Arrangement	Overhead Valves	Overhead Valves	Overhead Valves
Ignition System	Solid-state w/Magneto	Solid-state w/Magneto	Solid-state w/Magneto
Recommended Spark Plug	RC12YC	RC12YC	RC12YC
Spark Plug Gap	0.76 mm (0.030 inch)	0.508 mm (0.020 inch)	0.508 mm (0.020 inch)
Compression Ratio	8.6:1	9.5:1	9.5:1
Starter	12 Vdc	12 Vdc	12Vdc
Oil Capacity Including Filter	Approx. 1.5 Qts	Approx. 1.7 Qts	Approx. 1.7 Qts
Recommended Oil Filter	Generac Part # 70185	Generac Part # 70185	Generac Part # 70185
Recommended Air Filter	Generac Part # 0C8127	Generac Part # 0C8127	Generac Part # 0C8127
Operating RPM	3,600	3,600	3,600



## 1.6 FUEL REQUIREMENTS AND RECOMMENDATIONS

With LP gas, use only the vapor withdrawal system. This type of system uses the vapors formed above the liquid fuel in the storage tank.

The engine has been fitted with a fuel carburetion system that meets the specifications of the 1997 California Air Resources Board for tamper-proof dual fuel systems. The unit will run on natural gas or LP gas, but it has been factory set to run on natural gas. Should the primary fuel need to be changed to LP gas, the fuel system needs to be reconfigured. See Section 1.8 for instructions on reconfiguration of the fuel system.

Recommended fuels should have a Btu content of at least 1,000 BTU's per cubic foot for natural gas; or at least 2,520 BTU's per cubic foot for LP gas. Ask your fuel supplier for the BTU content of your fuel.

Fuel pressure for both natural gas and liquid propane set ups should be **11 inches to 14 inches of water column (0.6 psi)** at all load ranges.

**NOTE:**

**A separate gas line and regulator may be needed to assure proper gas pressure (11-14") to the generator. Low gas pressure can cause hard starting and could affect engine durability.**

## 1.7 FUEL CONSUMPTION

Model #	Nat. Gas (*)		LP Vapor (**)	
	1/2 Load	Full Load	1/2 Load	Full Load
04758	74	105	0.91/33	1.21/44.1
04759	114	185	1.34/48.9	2.17/79.0
04760	148.5	240	1.73/63.2	2.80/102.3

\*Natural gas is in cubic feet per hour.

\*\*LP is in gallons per hour/cubic feet per hour.



**⚠ Gaseous fuels such as natural gas and liquid propane (LP) gas are highly explosive. Even the slightest spark can ignite such fuels and cause an explosion. No leakage of fuel is permitted. Natural gas, which is lighter than air, tends to collect in high areas. LP gas is heavier than air and tends to settle in low areas.**

## 1.8 RECONFIGURING THE FUEL SYSTEM

### ◆ 1.8.1 7 KW, 410CC

To reconfigure the fuel system from NG to LP, follow these steps:

1. Turn the main gas supply off.
2. Remove the carburetor fuel hose from the outlet port of the demand regulator (Figure 1.3).

3. Disconnect wire #0 and wire #14 from the gas solenoid located on the top of the demand regulator.
4. Remove the demand regulator by rotating counterclockwise.
5. Remove the brass hose fitting from the outlet port of the demand regulator.
6. Remove the brass metering jet (loosen counterclockwise) from the housing port of the demand regulator located on the side of the regulator.
7. Install new LP metering jet (tighten clockwise) in the outlet port of the demand regulator.
8. Refit the brass hose fittings to the outlet port of the demand regulator.
9. Reverse procedure steps 1-4 to reinstall demand regulator.
10. Reverse the procedure to convert back to natural gas.

**Figure 1.3 – Demand Regulator**

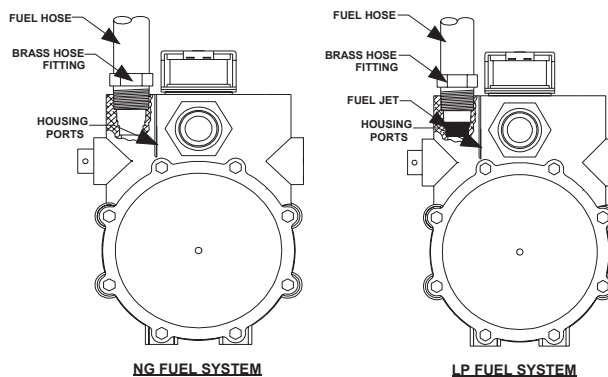

**NOTE:**

**The natural gas adjustment screw is preset during installation and should not need any further adjustment.**

### ◆ 1.8.2 12KW AND 15KW, 990CC ENGINES

To reconfigure the fuel system from NG to LP, follow these steps:

**NOTE:**

**The primary regulator for the propane supply is NOT INCLUDED with the generator. A fuel pressure of 11 to 14 inches of water column (0.6 psi) to the fuel inlet of the generator MUST BE SUPPLIED.**

1. Turn OFF the main gas supply.
2. Remove the engine air in baffle located on the left hand side of the battery compartment. Two M6 screws are located on top of the baffle and two M6 screws are located on the inside of the baffle towards the back.

3. Remove the small hose clamp and hose from the fuel regulator. It may be necessary to pry the hose off of the brass fitting using a screw driver to gently lift up the hose edge.
4. Remove the brass hose fitting screwed into the fuel regulator.
5. Locate and identify the brass idle jet. This will be located in the fuel regulator casting facing the front of the unit.
6. Remove the idle jet from its holding location.
7. Place the idle jet, thread side first, into the threaded hole originally occupied by the brass hose fitting.
8. Using a short No. 2 Phillips screw driver, thread the idle jet into the regulator casting. **DO NOT OVER TIGHTEN.**
9. Apply thread sealant to the threads of the hose fitting and replace it into the regulator body.
10. Re-attach the small hose and hose clamp and tighten as necessary.
11. Replace the engine air in baffle using the four M6 screws.
12. Identify both brass adjustment screws on the regulator.

**NOTE:**

**One adjustment screw can be accessed from the front of the unit and the second can be accessed from the back of the unit enclosure by removing the plastic hole plug.**

13. To adjust the system to run on LP fuel, turn the adjuster screw that can be accessed from inside the front of the unit,  $\frac{1}{4}$  TURN CLOCKWISE. This should now set the system for maximum power and best performance.
14. It may be necessary to make minor adjustments to the preset adjustment screw settings to achieve maximum power. If experiencing problems with the unit producing maximum power, follow the procedure in Section 2.6 (Adjusting the Fuel Regulator).

**Figure 1.4 - Demand Regulator**

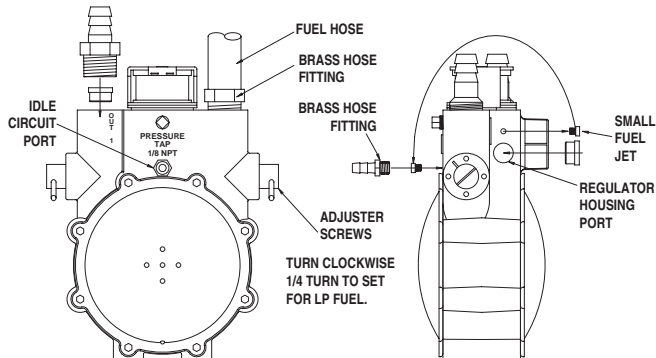

## 1.9 LOCATION

### ◆ 1.9.1 GENERATOR

Install the generator set, in its protective enclosure, outdoors, where adequate cooling and ventilating air is always available. Consider these factors:

- Install the unit where air inlet and outlet openings will not become obstructed by leaves, grass, snow, etc. If prevailing winds will cause blowing or drifting, you may need to consider using a windbreak to protect the unit.
- Install the generator on high ground where water levels will not rise and endanger it.
- Allow sufficient room on all sides of the generator for maintenance and servicing. A good rule is to allow three feet of space on all sides.
- Where strong prevailing winds blow from one direction, face the generator air inlet openings to the prevailing winds.
- Install the generator as close as possible to the fuel supply, to reduce the length of piping.
- Install the generator as close as possible to the transfer switch. **HOWEVER, REMEMBER THAT LAWS OR CODES MAY REGULATE THE DISTANCE.**

### ◆ 1.9.2 TRANSFER SWITCH

#### 1.9.2.1 7 kW, 12 kW and 15 kW Units

Transfer switches for use with these generators are sold separately and can be purchased from Generac Authorized Dealers.

- Install the transfer switch on a firm, sturdy supporting structure.
- To prevent switch distortion, level the switch if necessary. This can be done by placing washers between the switch enclosure and mounting surface.
- Never install the switch where water or any corrosive substance might drip onto the enclosure.
- Protect the switch at all times against excessive moisture, dust, dirt, lint, construction grit and corrosive vapors.
- Failure to utilize a Generac/Guardian transfer switch with this generator will void the warranty.

Transfer switches available for these generators are:

- Model 004678-0 — 100 Amp, 2 Pole, 250 Volt NEMA 1 (indoor rated) or
- Model 004635-0 — 200 Amp, 2 Pole, 250 Volt NEMA 3R (outdoor rated)

## 1.10 BATTERY INSTALLATION

Fill the battery with the proper electrolyte fluid if necessary and have the battery fully charged before installing it.

Before installing and connecting the battery, complete the following steps:

1. Set the generator's Auto/Off/Manual switch to OFF.
2. Turn off utility power supply to the transfer switch.
3. Remove the 5 amp and 15 amp fuses from the generator control panel.

### ⚠ WARNING ⚠

⚠ If the Auto/Off/Manual switch is not set to its OFF position, the generator can crank and start as soon as the battery cables are connected. If the utility power supply is not turned off, sparking can occur at the battery posts and cause an explosion.

Battery cables were factory connected at the generator (Figure 1.5). Connect cables to battery posts as follows:

4. Connect the red battery cable (from starter contactor) to the battery post indicated by a positive, POS or (+).
5. Connect the black battery cable (from frame ground) to the battery post indicated by a negative, NEG or (—).
6. Replace the 5 amp and 15 amp fuses in the generator control panel.

### NOTE:

Damage will result if battery connections are made in reverse.

Figure 1.5 – Battery Cable Connections

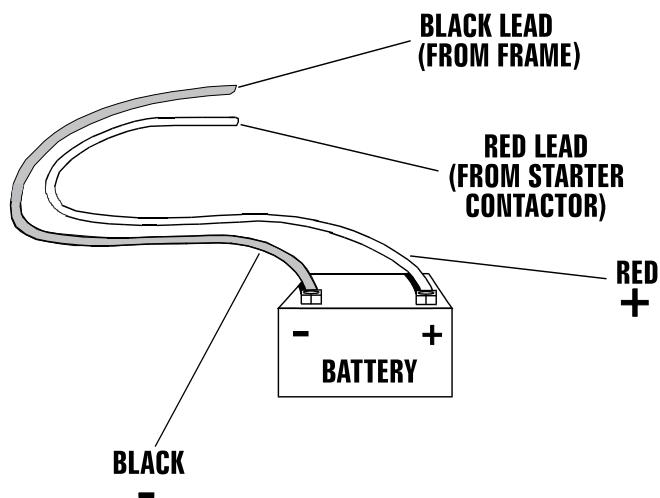

### NOTE:

Your generator is equipped with a battery trickle charger that is active when your unit is set up for automatic operation. With the battery installed and utility power source voltage available to the transfer switch, the battery receives a trickle charge while the engine is not running, to prevent self-discharge. The trickle charger is designed to help extend the life of your battery by maintaining the battery when the unit is not running. The trickle charge feature cannot be used to recharge a discharged battery.

## 1.11 THE BATTERY

Servicing of the battery is to be performed or supervised by personnel knowledgeable of batteries and the required precautions. Keep unauthorized personnel away from batteries.

When replacing the battery, use the following type of battery: Group 26/26R 12-volt battery with a rating of 350 cold-cranking amps minimum for 7 kW; 550 cold-cranking amps minimum for 12 and 15 kW at -18° C (0° F) minimum. When using a maintenance-free battery, it is not necessary to check the specific gravity or electrolyte level. Have these procedures performed at the intervals specified in the "Service Schedule." A negative ground system is used. Battery connections are shown on the wiring diagrams. Make sure the battery is correctly connected and terminals are tight. Observe battery polarity when connecting the battery to the generator set.

### ⚠ DANGER ⚠

⚠ Do not dispose of the battery in a fire. The battery is capable of exploding.

⚠ A battery presents a risk of electrical shock and high short circuit current. The following precautions are to be observed when working on batteries:

- Remove watches, rings or other metal objects;
- Use tools with insulated handles;
- Wear rubber gloves and boots;
- Do not lay tools or metal parts on top of the battery; and
- Disconnect charging source prior to connecting or disconnecting battery terminals.

### ⚠ WARNING ⚠

⚠ Do not open or mutilate the battery. Released electrolyte has been known to be harmful to the skin and eyes, and to be toxic.

⚠ The electrolyte is a dilute sulfuric acid that is harmful to the skin and eyes. It is electrically conductive and corrosive.

The following procedures are to be observed:

- Wear full eye protection and protective clothing;
- Where electrolyte contacts the skin, wash it off immediately with water;
- Where electrolyte contacts the eyes, immediately flush thoroughly with water and seek medical attention; and
- Spilled electrolyte is to be washed down with an acid neutralizing agent. A common practice is to use a solution of 1 pound (500 grams) bicarbonate of soda to 1 gallon (4 liters) or water. The bicarbonate of soda solution is to be added until the evidence of reaction (foaming) has ceased. The resulting liquid is to be flushed with water and the area dried.

 Lead-acid batteries present a risk of fire because they generate hydrogen gas. The following procedures are to be followed:

- DO NOT SMOKE when near the battery;
- DO NOT cause flame or spark in battery area; and
- Discharge static electricity from your body before touching the battery by first touching a grounded metal surface.

 Be sure the Auto/Off/Manual switch is set to the OFF position before connecting the battery cables. If the switch is set to AUTO or MANUAL, the generator can crank and start as soon as the battery cables are connected.

 Be sure the utility power supply is turned off, or sparking may occur at the battery posts as you attach the cables and cause an explosion.

## 2.1 BEFORE INITIAL START-UP

Before starting, complete the following:

1. Set the generator's main circuit breaker to its OFF (or open) position.
2. Set the generator's Auto/Off/Manual switch to the OFF position.
3. Turn OFF the utility power supply to the transfer switch using the means provided (such as the utility main line circuit breaker).
4. Check the engine crankcase oil level and, if necessary, fill to the dipstick FULL mark with the recommended oil. Do not fill above the FULL mark.
5. Check the fuel supply. Gaseous fuel lines must have been properly purged and leak tested in accordance with applicable fuel-gas codes. All fuel shutoff valves in the fuel supply lines must be open.

 CAUTION 

 Never operate the engine with the oil level below the "Add" mark on the dipstick. Doing this could damage the engine.

## 2.2 CHECK TRANSFER SWITCH OPERATION

Refer to Section 3.5 (Page 15), of the owner's manual for manual operation procedures.

 **DANGER** 

 Do not attempt manual transfer switch operation until all power voltage supplies to the transfer switch have been positively turned off. Failure to turn off all power voltage supplies will result in extremely hazardous and possibly fatal electrical shock.

## 2.3 ELECTRICAL CHECKS

Complete electrical checks as follows:

1. Turn on the utility power supply to the transfer switch using the means provided (such as a utility main line circuit breaker).

 **DANGER** 

 The transfer switch is now electrically "hot." Contact with "hot" parts will result in extremely hazardous and possibly fatal electrical shock. Proceed with caution.

2. Use an accurate AC voltmeter to check utility power source voltage across terminals N1 and N2. Nominal line-to-line voltage should be 240 volts AC.
3. Check utility power source voltage across terminals N1 and the transfer switch neutral lug; then across terminal N2 and neutral. Nominal line-to-neutral voltage should be 120 volts AC.
4. When certain that utility supply voltage is compatible with transfer switch and load circuit ratings, turn OFF the utility power supply to the transfer switch.
5. Set the generator's main circuit breaker to its OFF (or open) position. Initial tests will be conducted at no-load condition.
6. On the generator panel, set the Auto/Off/Manual switch to MANUAL. The engine should crank and start.
7. Let the engine warm up for about five minutes to allow internal temperatures to stabilize. Then, set the generator's main circuit breaker to its ON (or closed) position.

 **DANGER** 

 Proceed with caution! Generator power voltage is now supplied to the transfer switch. Contact with live transfer switch parts will result in dangerous and possibly fatal electrical shock.

8. Connect an accurate AC voltmeter and a frequency meter across transfer switch terminal lugs E1 and E2. Voltage should be 242-252 volts; frequency should read about 61-63 Hertz.
9. Connect the AC voltmeter test leads across terminal lug E1 and neutral; then across E2 and neutral. In both cases, voltage reading should be 121-126 volts AC.
10. Set the generator's main circuit breaker to its OFF (or open) position. Let the engine run at no-load for a few minutes to stabilize internal engine generator temperatures.
11. Set the generator's Auto/Off/Manual switch to OFF. The engine should shut down.

**NOTE:**

**It is important that you do not proceed until you are certain that generator AC voltage and frequency are correct and within the stated limits. Generally, if both AC frequency and voltage are high or low, the engine governor requires adjustment. If frequency is correct, but voltage is high or low, the generator's voltage regulator requires adjustment.**

## 2.4 GENERATOR TESTS UNDER LOAD

To test the generator set with electrical loads applied, proceed as follows:

1. Set generator's main circuit breaker to its OFF (or open) position.
2. Set the generator's Auto/Off/Manual switch to OFF.
3. Turn OFF the utility power supply to the transfer switch, using the means provided (such as a utility main line circuit breaker).

**WARNING**

**Do not attempt manual transfer switch operation until all power voltage supplies to the transfer switch have been positively turned off. Failure to turn off all power voltage supplies will result in extremely hazardous and possibly fatal electrical shock.**

4. Manually set the transfer switch to the STANDBY position, i.e., load terminals connected to the generator's E1/E2 terminals. The transfer switch operating lever should be down.
5. Set the generator's Auto/Off/Manual switch to MANUAL. The engine should crank and start immediately.
6. Let the engine stabilize and warm up for a few minutes.
7. Set the generator's main circuit breaker to its ON (or closed) position. Loads are now powered by the standby generator.

8. Turn ON electrical loads. Apply an electrical load equal to the full rated wattage/amperage capacity of the installed generator.
9. Connect an accurate AC voltmeter and a frequency meter across terminal lugs E1 and E2. Voltage should be greater than 230 volts; frequency should be greater than 58 Hertz.
10. Let the generator run at full rated load for 20-30 minutes. Listen for unusual noises, vibration or other indications of abnormal operation. Check for oil leaks, evidence of overheating, etc.
11. When testing under load is complete, turn OFF electrical loads.
12. Set the generator's main circuit breakers to their OFF (or open) positions.
13. Let the engine run at no-load for a few minutes.
14. Set the Auto/Off/Manual switch to OFF. The engine should shut down.

## 2.5 CHECKING AUTOMATIC OPERATION

To check the system for proper automatic operation, proceed as follows:

1. Set the generator's main circuit breaker to its OFF (or open) position.
2. Check that the Auto/Off/Manual switch is set to OFF.
3. Turn OFF the utility power supply to the transfer switch using the means provided (such as a utility main line circuit breaker).
4. Manually set the transfer switch to the UTILITY position, i.e., load terminals connected to the utility power source side.
5. Turn ON the utility power supply to the transfer switch, using the means provided (such as a utility main line circuit breaker).
6. Set the Auto/Off/Manual switch to AUTO. Then set the generator's main circuit breaker to its ON (or closed) position. The system is now ready for automatic operation.
7. Turn OFF the utility power supply to the transfer switch.

With the Auto/Off/Manual switch at AUTO, the engine should crank and start when the utility source power is turned OFF. After starting, the transfer switch should connect load circuits to the standby side. Let the system go through its entire automatic sequence of operation.

With the generator running and loads powered by generator AC output, turn ON the utility power supply to the transfer switch. The following should occur:

- After about six seconds, the switch should transfer loads back to the utility power source.
- About one minute after retransfer, the engine should shut down.

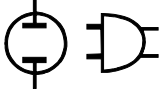

## 2.6 ADJUSTING THE REGULATOR (NATURAL GAS ONLY)

Although the generator has been factory set to provide maximum power, it may be necessary in some areas to adjust this setting. Because natural gas has different BTU or power content across the country the engine may not perform as designed.

If you experience engine problems at high or full load conditions follow these steps. It will require a frequency meter to perform this procedure.

1. Turn off utility power to the main distribution panel in the house. This can be done by switching the service main breaker to the off or open position.
2. Allow the generator to start before loading the generator. Confirm the no-load frequency with the roof open and door off is set at 63-63.5 Hz. Transfer load to emergency circuits.
3. Turn on appliances, lights, pumps, etc., that are on the emergency circuits in an attempt to fully load the generator. Be cautious not to overload the generator. Use the following chart as a guide:

Unit	120 Volts	240 Volts
7 kW	50.0 amps	25.0 amps
12 kW	100.0 amps	50.0 amps
15 kW	108.3 amps	54.2 amps

4. When full load has been achieved. Connect a frequency meter to the output lugs of the generator's main line circuit breaker.
5. The fuel regulator is fitted with one (7 kW), or two (12 & 15 kW) adjustment screws. While watching the frequency meter, slowly turn the adjustment screw clockwise or counterclockwise one at a time until highest frequency is read on the meter. Only limited adjustment is available between the set pins. Under no circumstances should any of the pins be removed (Figures 2.1 and 2.2).

Figure 2.1 — Dual Fuel Regulators

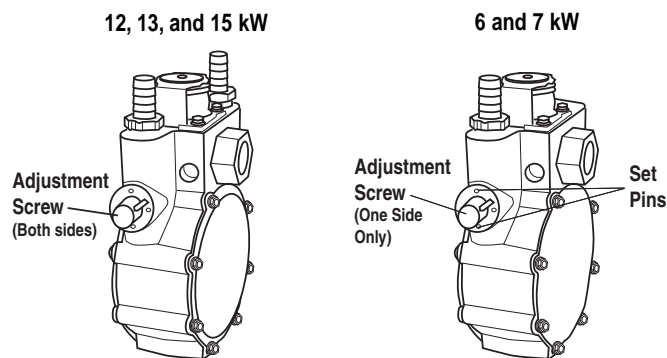

6. When the highest frequency is reached maximum power has been set. Then turn both adjustment screws 1/4 turn counterclockwise. Regulator is now set.

Figure 2.2 — Placement of Regulator

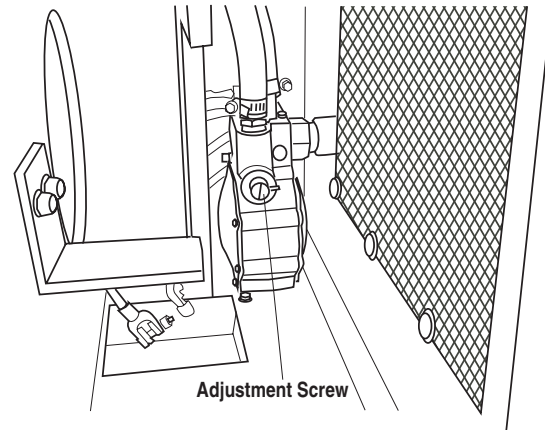

7. Turn utility power to the main distribution panel back on. This can be done by switching the service main breaker to the on or closed position. Allow the generator to shut down.

### ⚠ WARNING ⚠

- ⚠ Do not make any unnecessary adjustments. Factory settings are correct for most applications. However, when making adjustments, be careful to avoid overspeeding the engine.

If this procedure or equipment are not available to you, locate the Generac Guardian Dealer nearest you and they can perform the adjustments.

### NOTE:

A service fee may be charged for this adjustment.

## 2.7 ENGINE GOVERNOR ADJUSTMENT

If both AC frequency and voltage are correspondingly high or low, adjust the engine governor as follows:

### ◆ 2.7.1 7 KW UNITS

1. Loosen the governor clamp bolt (Figure 2.3 on page 13).
2. Hold the governor lever at its wide open throttle position, and rotate the governor shaft clockwise as far as it will go. Then, tighten the governor lever clamp bolt to 70 inch-pounds (8 N-m).
3. Start the generator; let it stabilize and warm up at no-load.
4. Connect a frequency meter across the generators AC output leads.
5. Turn the speed adjust nut to obtain a frequency reading of 63 Hz.
6. When frequency is correct at no load, check the AC voltage reading. If voltage is incorrect, the voltage regulator may require adjustment.

Figure 2.3 — Engine Governor Adjustment

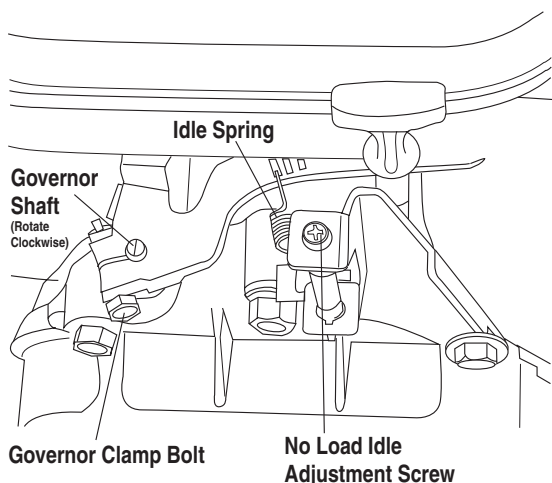

◆ 2.7.2 12 KW AND 15 KW UNITS

1. Loosen governor clamp bolt (See Figure 2.3).
2. Completely remove the idle spring.
3. With governor arm at wide open throttle position, rotate governor shaft fully clockwise. Tighten clamp bolt to 84 inch-pounds.
4. Start unit and apply full load. Use full load speed adjust screw (Figure 2.4) to adjust frequency to 58 Hz.
5. Remove load, stop engine, loosen the idle adjust screw and reconnect the idle spring.
6. Using your hand, push the governor arm to the closed throttle position. Make sure the idle spring does not stretch at all.
7. Restart the unit.
8. Slowly turn the idle adjust screw to adjust the no-load idle frequency to 63-63.5 Hz.
9. The governor is now set.

Figure 2.4 — Full Load Speed Adjust Screw

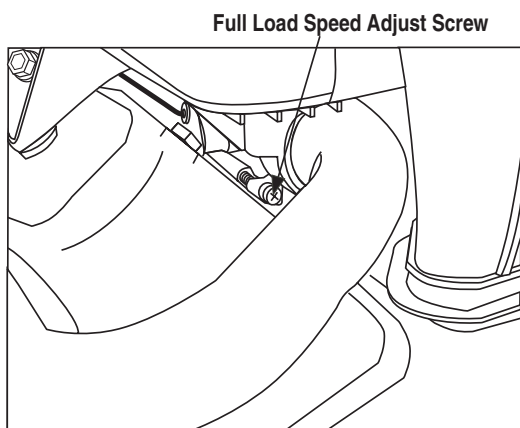

◆ 2.7.3 ADDITIONAL CORROSION PROTECTION

Periodically spray all engine linkage parts and brackets with corrosion inhibiting spray such as WD-40 or a comparable product.

2.8 VOLTAGE REGULATOR ADJUSTMENT

With the frequency between 62-63.5 Hertz, slowly turn the slotted potentiometer (Figure 2.5) until line voltage reads 244-252 volts.

NOTE:

**You must remove the access panel on top of the control panel to adjust the voltage regulator.**

Figure 2.5 – Voltage Adjustment Potentiometer

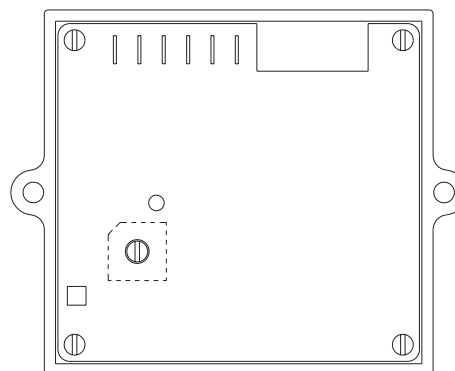

NOTE:

**The voltage regulator is housed above the generator's control panel. The regulator maintains a voltage in direct proportion to frequency. For example, at 62 Hertz, line-to-neutral voltage will be 124 volts.**

3.1 BREAK-IN PROCEDURE

Once the unit has been installed, with utility power connected to the transfer switch, and all electrical checks have been made, it is strongly recommended that the following "Break-in Procedure" be completed to ensure correct generator operation in the future.

1. Set the generator's Auto/Off/Manual switch to AUTO.
2. Turn OFF the utility power supply to the transfer switch using the means provided (such as a utility main line circuit breaker).
3. The unit will start, and the transfer switch will transfer to standby.
4. Run the unit for one hour at 25 percent load.
5. Run the unit for one hour at 50 percent load.
6. Run the unit for one hour at 75 percent load.
7. Run the unit for one hour at 100 percent load.

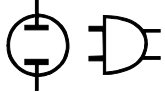

8. Turn ON the utility power supply to the transfer switch, which will allow the transfer switch to transfer back to utility power. The unit will continue to run for one minute and then shut down.
9. Allow the unit to cool.
10. Drain the oil and remove the oil filter. Replace the oil filter according to Section 4.4, “Changing the Oil Filter” (Page 18). Replace the oil with synthetic oil as recommended in Section 4.3, “Changing the Engine Oil” (Page 17).
11. The generator is now ready for service.

## 3.2 USING THE AUTO/OFF/MANUAL SWITCH (FIGURE 3.1)

### ◆ 3.2.1 “AUTO” POSITION

Selecting this switch position activates fully automatic system operation. It also allows you to start and exercise the engine every seven days with the setting of the exercise timer (see Section 3.6, Page 16). This position also is used for remote starting, when it is set up.

### ◆ 3.2.2 “OFF” POSITION

This switch position shuts down the engine. This position also prevents automatic operation.

### ◆ 3.2.3 “MANUAL” POSITION

Set the switch to MANUAL to crank and start the engine. Transfer to standby power will not occur unless there is a utility failure.

Figure 3.1 – Generator Control Panel

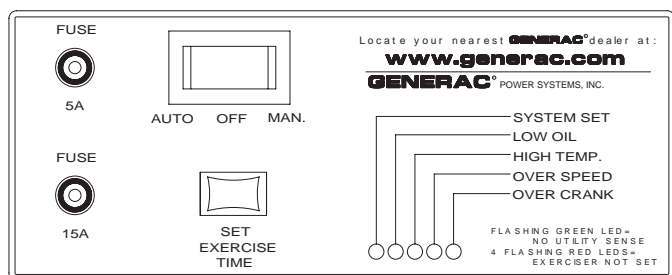

## ⚠ WARNING ⚠

⚠ With the switch set to AUTO, the engine may crank and start at any time without warning. Such automatic starting normally occurs when utility power source voltage drops below a preset level or during the normal exercise cycle. To prevent possible injury that might be caused by such sudden starts, always set the switch to OFF and remove both fuses before working on or around the generator or transfer switch. Then, place a “Do Not Operate” tag on the generator panel and on the transfer switch.

## 3.3 AUTOMATIC TRANSFER OPERATION

To select automatic operation, do the following:

1. Make sure the transfer switch main contacts are set to their “Utility” position, i.e., loads connected to the utility power source (Figure 3.2, Page 15).
2. Be sure that normal utility power source voltage is available to transfer switch terminal lugs N1 and N2.
3. Set the generator’s Auto/Off/Manual switch to AUTO.
4. Set the generator’s main circuit breaker to its ON (or closed) position.

With the preceding steps complete, the generator will start automatically when utility source voltage drops below a preset level. After the unit starts, loads are transferred to the standby power source. Refer to Section 3.4, “Sequence of Automatic Operation.”

## 3.4 SEQUENCE OF AUTOMATIC OPERATION

The generator’s control panel houses a control logic circuit board. This board constantly monitors utility power source voltage. Should that voltage drop below a preset level, circuit board action will signal the engine to crank and start. After the engine starts, the circuit board signals the transfer switch to activate and connect load circuits to the standby power supply (load terminal lugs T1/T2 connect to terminal lugs E1/E2).

Upon restoration of utility source voltage above a preset level, generator circuit board action signals the transfer switch to transfer loads back to that power supply. After retransfer, the engine is signalled to shut down.

The actual sequence of operation is controlled by sensors and timers on a control logic circuit board, as follows:

- A. Utility Voltage Dropout Sensor
  - This sensor monitors utility source voltage.
  - If utility source voltage drops below about 70 percent of the nominal supply voltage, the sensor energizes a 15-second timer.
  - Once the timer has expired, the engine will crank and start.
- B. Engine Warm-up Time Delay
  - This mechanism lets the engine warm up for about 10 seconds before the load is transferred to a standby source.
- C. Standby Voltage Sensor
  - This sensor monitors generator AC output voltage. When the voltage has reached 50 percent of the nominal rated voltage, transfer to standby can occur.



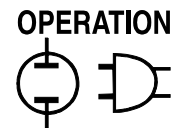

#### D. Utility Voltage Pickup Sensor

- This sensor monitors utility power supply voltage. When that voltage is restored to above 70 percent of the nominal source voltage, a retransfer time delay starts timing.

#### E. Retransfer Time Delay

- This timer runs for about 15 seconds.
- At end of a 15-second delay, circuit board action de-energizes the transfer relay in the transfer switch.
- Retransfer to utility power source then occurs.

#### F. Engine Cool-down Timer

- When the load is transferred back to utility power source, the engine cool-down timer starts timing.
- The timer will run for about one minute, and the generator will then shut down.

## 3.5 MANUAL TRANSFER OPERATION

### ◆ 3.5.1 TRANSFER TO GENERATOR POWER SOURCE

To start the generator and activate the transfer switch manually, proceed as follows:

1. Set the generator's main circuit breaker to its OFF (or open) position.
2. Set the generator's Auto/Off/Manual switch to OFF.
3. Turn OFF the utility power supply to the transfer switch using the means provided (such as a utility main line circuit breaker).



- ⚠ Do not attempt to activate the transfer switch manually until all power voltage supplies to the switch have been positively turned off. Failure to turn off all power voltage supplies may result in extremely hazardous and possibly fatal electrical shock.**

4. Use the manual transfer handle inside the transfer switch to move the main contacts to their "Standby" position, i.e., loads connected to the standby power source (Figure 3.2).
5. To crank and start the engine, set the Auto/Off/Manual switch to MANUAL.
6. Let the engine stabilize and warm up for a few minutes.
7. Set the generator's main circuit breaker to its ON (or closed) position. The standby power source now powers the loads.

**Figure 3.2 – Manual Transfer Switch Operation**

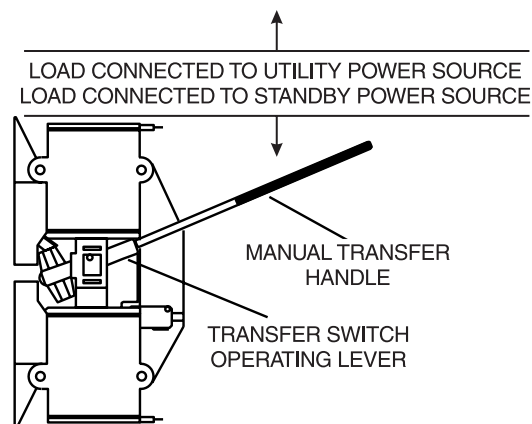

### ◆ 3.5.2 TRANSFER BACK TO UTILITY POWER SOURCE

When utility power has been restored, you will want to transfer back to that source and shut down the generator. This can be accomplished as follows:

1. Set the generator's main circuit breaker to its OFF (or open) position.
2. Let the engine run for a minute or two at no-load to stabilize the internal temperatures.
3. Set the generator's Auto/Off/Manual switch to its OFF (or open) position. The engine should shut down.
4. Check that utility power supply to the transfer switch is turned OFF.



- ⚠ Do not attempt to activate the transfer switch manually until all power voltage supplies to the switch have been positively turned off. Failure to turn off all power voltage supplies may result in extremely hazardous and possibly fatal electrical shock.**

5. Use the manual transfer handle inside the transfer switch to move the main contacts back to their "Utility" position, i.e., loads connected to the utility power source (Figure 3.2).
6. Turn ON the utility power supply to the transfer switch using the means provided.
7. Set the system to automatic operation as outlined in "Automatic Transfer Operation," Section 3.3 (Page 14).

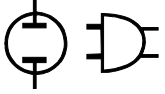

### 3.6 SETTING THE EXERCISE TIMER

Your generator is equipped with an exercise timer. Once it is set, the generator will start and exercise once every seven days, on the day of the week and at the time of day you complete the following sequence. During this exercise period, the unit runs for approximately 12 minutes and then shuts down. Transfer of loads to the generator output does not occur during the exercise cycle.

A switch on the control panel (see Figure 3.1, Page 14) allows you to select the day and time for system exercise. To select the desired day and time of day, you must perform the following sequence at that time.

1. Verify that the Auto/Off/Manual switch is set to AUTO.
2. Hold down the set timer switch until the generator starts (approximately 10 seconds) and then release.
3. The generator will start and run for approximately 12 minutes and then shut down on its own. The exerciser will then be set to run at that time of day every week.

**NOTE:**

**The exerciser will only work in the AUTO mode and will not work unless this procedure is performed. The exerciser will need to be reset every time the 12-volt battery is disconnected and then reconnected. The exerciser WILL NOT work if dip switch 2 (Remote Not Auto) on the controller printed circuit board is ON.**

### 3.7 PROTECTION SYSTEMS

#### ◆ 3.7.1 LOW OIL PRESSURE SWITCH

This switch (Figure 3.3) has normally closed contacts that are held open by engine oil pressure during cranking and operating. Should oil pressure drop below the 8 psi range, switch contacts close, and the engine shuts down. The unit should not be restarted until oil is added, and the Auto/Off/Manual switch must be turned to OFF and then back to AUTO.

#### ◆ 3.7.2 HIGH TEMPERATURE SWITCH

This switch's contacts (Figure 3.3) close if the temperature should exceed approximately 140° C (284° F), initiating an engine shutdown. Your generator will automatically restart and the LED will reset once the temperature has returned to a safe operating level.

**Figure 3.3 – Low Oil Pressure and High Temperature Switches**

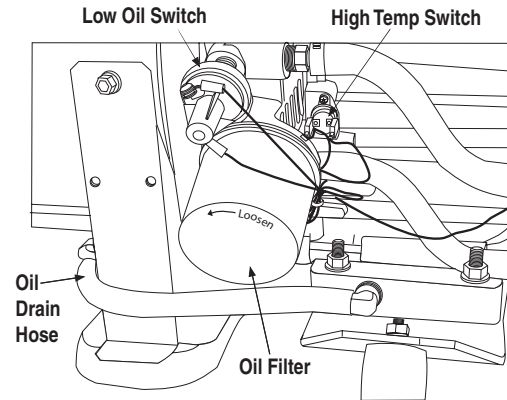

#### ◆ 3.7.3 OVERCRANK

This feature prevents the generator from damaging itself when it continually attempts to start and another problem, such as no fuel supply, prevents it from starting. The unit will crank and rest for a preset time limit. Then, it will stop cranking, and the LED will light indicating an overcrank failure. The Auto/Off/Manual switch will need to be set to OFF and then back to AUTO to reset the generator control board.

**NOTE:**

**If the fault is not repaired, the overcrank feature will continue to activate.**

##### 3.7.3.1 Approximate Crank Cycle Times

- 15 seconds ON
- 7 seconds OFF
- 7 seconds ON
- 7 seconds OFF
- Repeat for 45 seconds
- Approximately 90 seconds total

#### ◆ 3.7.4 OVERSPEED

This feature protects the generator from damage by shutting it down if it happens to run faster than the preset limit. This protection also prevents the generator from supplying an output that could potentially damage appliances connected to the generator circuit. Contact your nearest Generac Authorized Dealer if this failure occurs.

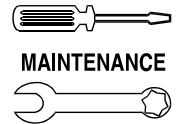

MAINTENANCE

## 4.1 FUSE

The generator panel's 15 amp fuse (Figure 4.1) protects the DC control circuit against overload. The fuse is wired in series with the battery output lead to the panel. If the fuse element has melted open, you cannot crank or start the engine. You should replace the fuse using only an identical 15-amp replacement.

The generator panel's 5 amp fuse protects the battery charge circuit against overload. If the fuse element has melted open, you will not have battery charging capability. You should replace the fuse using only an identical 5 amp replacement. To remove fuse, push cap down and rotate counterclockwise.

Figure 4.1 – Generator Control Panel

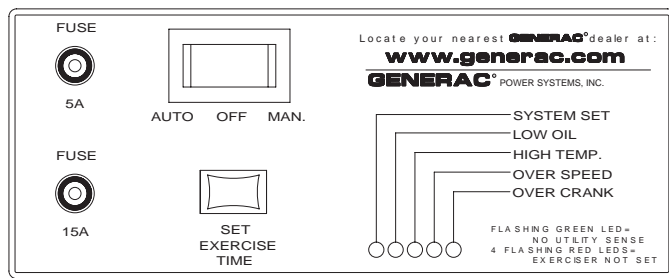

## 4.2 CHECKING THE ENGINE OIL LEVEL

For oil capacities, see “Specifications,” Section 1.5 (Page 6). For engine oil recommendations, see Section 4.3.1. To check the engine oil level, proceed as follows (Figure 4.2):

1. Start the generator by moving the Auto/Off/Manual switch to the MANUAL position. Allow it to run for a short while and then shut it down by moving the switch to the OFF position.
2. Remove the dipstick and wipe it dry with a clean cloth.
3. Install the dipstick; then, remove it again. The oil level should be at the dipstick “Full” mark. If necessary, add oil to the “Full” mark only. **DO NOT FILL ABOVE THE “FULL” MARK.**



CAUTION

⚠ Never operate the engine with the oil level below the “Add” mark on the dipstick. Doing this could damage the engine.

4. Install the dipstick.
5. Reset the Auto/Off/Manual switch to its original position.

Figure 4.2 — Oil Dipstick and Fill, 7 kW

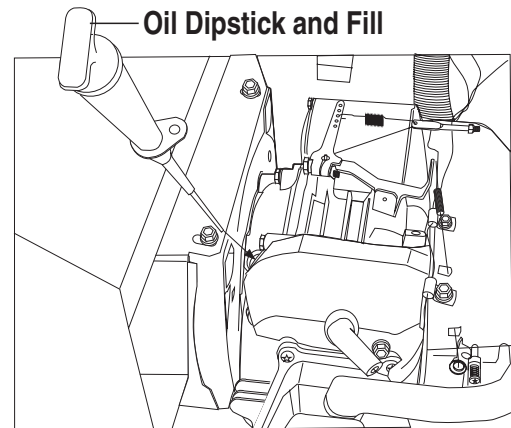
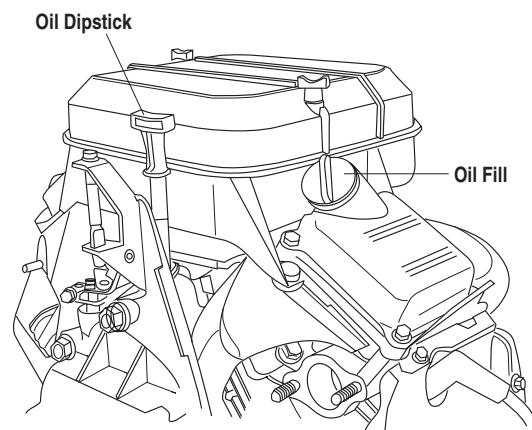

Figure 4.3 — Oil Dipstick and Fill, 12 kW and 15 kW



## 4.3 CHANGING THE ENGINE OIL

### ◆ 4.3.1 ENGINE OIL RECOMMENDATIONS

Use oil of American Petroleum Institute (API) Service Class SG, SH or SJ. Use all season SAE 5W-30 Synthetic oil. Organic break-in oil is required before using synthetic oil.

#### NOTE:

The unit is supplied with “break-in” oil. See the “Break-in Procedure,” Section 3.1 (Page 12), for the first required oil change.



CAUTION

⚠ Any attempt to crank or start the engine before it has been properly serviced with the recommended oil may result in an engine failure.

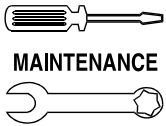

### ◆ 4.3.2 OIL CHANGE PROCEDURE

To change the oil, proceed as follows:

1. Run the engine until it is thoroughly warmed up then shut OFF the engine.
2. Immediately after the engine shuts OFF, pull the oil drain hose (Figure 4.4) free of its retaining clip. Remove the cap from the hose and drain the oil into a suitable container.

**Figure 4.4 – Oil Drain Hose and Filter**

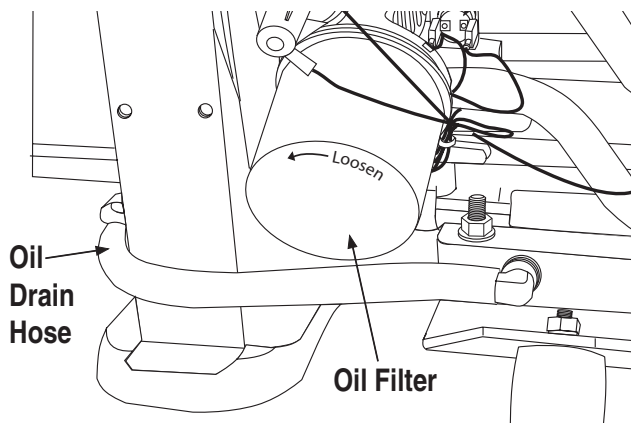

3. After the oil has drained, replace the cap onto the end of the oil drain hose. Retain the hose in the clip.
4. Refill with the proper recommended oil (see Section 4.3.1). See Section 1.5.2 (Page 6) for oil capacities.

### 4.4 CHANGING THE OIL FILTER

Change the engine oil filter as follows:

1. With the oil drained, remove the old oil filter by turning it counterclockwise.
2. Apply a light coating of clean engine oil to the gasket of the new filter. See Section 1.5.1 (Page 6) for recommended filter.
3. Screw the new filter on by hand until its gasket lightly contacts the oil filter adapter. Then, tighten the filter an additional 3/4 to one turn (Figure 4.4).
4. Refill with the proper recommended oil (see Section 4.3.1, Page 17). See Section 1.5.2 (Page 6) for oil capacities.
5. Start the engine and check for leaks.

## 4.5 CHANGING THE ENGINE AIR CLEANER

### ◆ 4.5.1 7 kW, 12 kW AND 15 kW GENERATORS

See Figures 1.1 and 1.2, (Page 5), for the location of your air cleaner. Use the following procedure (Figure 4.6):

1. Turn the two screws counterclockwise to loosen.
2. Remove the cover and air filter.
3. Wipe away dust or debris from inside of the air box and around edges.
4. Install the new air cleaner into the air box.
5. Install the cover. Turn the two cover screws clockwise to tighten.

See the “Service Schedule,” Section 4.13 (Page 22) for air cleaner maintenance. See Section 1.5.1 (Page 6) for air filter replacement part number.

**Figure 4.6 — 7 kW, Engine Air Cleaner Location**

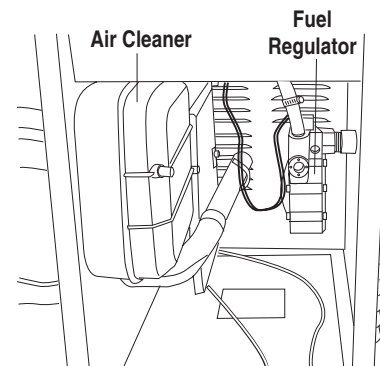

**Figure 4.7 — 12 kW and 15 kW Engine Air Cleaner**

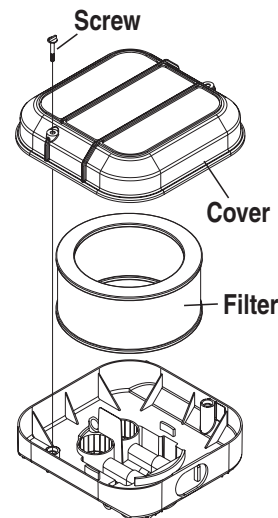

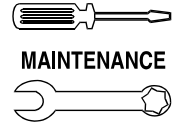

MAINTENANCE

## 4.6 SPARK PLUG(S)

Reset the spark plug(s) gap or replace the spark plug(s) as necessary. See Section 4.13 (Page 22) for maintenance requirements.

1. Clean the area around the base of the spark plug(s) to keep dirt and debris out of the engine. Clean by scraping or washing using a wire brush and commercial solvent. Do not blast the spark plug(s) to clean.
2. Remove the spark plug(s) and check the condition. Replace the spark plug(s) if worn or if reuse is questionable. See Section 4.13 (Page 22) for recommended inspection.
3. Check the spark plug gap using a wire feeler gauge. Adjust the gap to 0.76 mm (0.030 inch) for 7 kW and 0.50 mm (0.020 inch) for 12/15 kW by carefully bending the ground electrode (Figure 4.8).

**Figure 4.8 – Setting the Spark Plug Gap**

SET PLUG GAP AT 0.76 mm/0.50 mm  
(0.030 inch/0.020 inch)

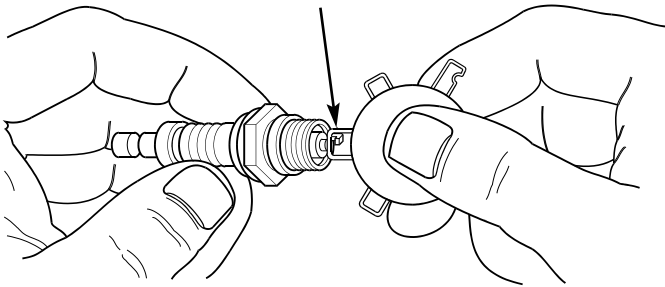

## 4.7 BATTERY MAINTENANCE

The battery should be inspected per the “Service Schedule,” Section 4.13 (Page 22). The following procedure should be followed for inspection:

1. Inspect the battery posts and cables for tightness and corrosion. Tighten and clean as necessary.
2. Check the battery fluid level of unsealed batteries and, if necessary, fill with **DISTILLED WATER ONLY. DO NOT USE TAP WATER IN BATTERIES.**
3. Have the state of charge and condition checked. This should be done with an automotive-type battery hydrometer.

**⚠ DANGER ⚠**

**⚠ Do not dispose of the battery in a fire. The battery is capable of exploding.**

**⚠ A battery presents a risk of electrical shock and high short circuit current. The following precautions are to be observed when working on batteries:**

- Remove watches, rings or other metal objects;
- Use tools with insulated handles;
- Wear rubber gloves and boots;
- Do not lay tools or metal parts on top of the battery; and
- Disconnect charging source prior to connecting or disconnecting battery terminals.

**⚠ WARNING ⚠**

**⚠ Do not open or mutilate the battery. Released electrolyte has been known to be harmful to the skin and eyes, and to be toxic.**

**⚠ The electrolyte is a dilute sulfuric acid that is harmful to the skin and eyes. It is electrically conductive and corrosive. The following procedures are to be observed:**

- Wear full eye protection and protective clothing;
- Where electrolyte contacts the skin, wash it off immediately with water;
- Where electrolyte contacts the eyes, immediately flush thoroughly with water and seek medical attention; and
- Spilled electrolyte is to be washed down with an acid neutralizing agent. A common practice is to use a solution of 1 pound (500 grams) bicarbonate of soda to 1 gallon (4 liters) or water. The bicarbonate of soda solution is to be added until the evidence of reaction (foaming) has ceased. The resulting liquid is to be flushed with water and the area dried.

**⚠ Lead-acid batteries present a risk of fire because they generate hydrogen gas. The following procedures are to be followed:**

- **DO NOT SMOKE** when near the battery;
- **DO NOT** cause flame or spark in battery area; and
- **Discharge static electricity from your body before touching the battery by first touching a grounded metal surface.**

**⚠ Be sure the Auto/Off/Manual switch is set to the OFF position before connecting the battery cables. If the switch is set to AUTO or MANUAL, the generator can crank and start as soon as the battery cables are connected.**

**⚠ Be sure the utility power supply is turned off, and the 5A fuse is removed from the generator control panel, or sparking may occur at the battery posts as you attach the cables causing an explosion.**

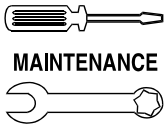

## Section 4 – Maintenance

### Guardian Air-cooled 7 kW, 12 kW and 15 kW Generators

#### 4.8 ADJUSTING VALVE CLEARANCE

After the first 50 hours of operation, you should adjust the valve clearance in the engine.

**Important:** If you feel uncomfortable about doing this procedure or you don't have the proper tools, please contact your Generac Authorized dealer for service assistance. This is a very important step to insure longest life for your engine.

##### To adjust valve clearance:

- Make sure the engine is at room temperature.
- Make sure that the spark plug wire is removed from the spark plug and out of the way.
- Remove the four screws attaching the valve cover with a #2 or #3 phillips screwdriver.
- Make sure the piston is at Top Dead Center (TDC) of its compression stroke (both valves closed). To get the piston at TDC, remove the intake screen at the front of the engine to gain access to the flywheel nut. Use a large socket and socket wrench to rotate the nut and hence the engine. While watching the piston through the spark plug hole. The piston should move up and down. The piston is at TDC when it is up as high as it can go.
- Loosen the rocker jam nut. Use an 10mm allen wrench to turn the pivot ball stud while checking clearance between the rocker arm and the valve stem with a feeler gauge. Correct clearance is 0.002-0.004 inch (0.05-0.1 mm).

##### NOTE:

**You must hold the rocker arm jam nut in place as you turn the pivot ball stud.**

When valve clearance is correct, hold the pivot ball stud in place with the allen wrench and tighten the rocker arm jam nut. Tighten the jam nut to 174 in/lbs. torque. After tightening the jam nut, recheck valve clearance to make sure it did not change.

Figure 4.10 - Valve Clearance Adjustment

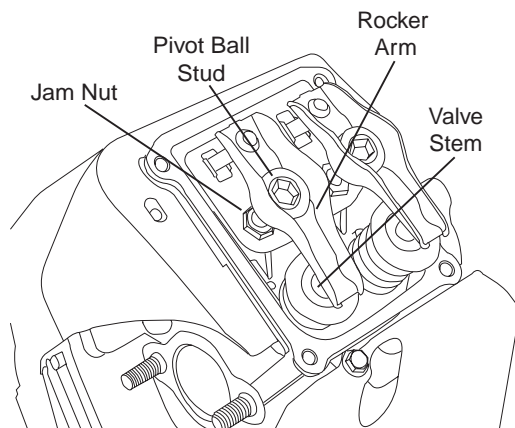

- Install new valve cover gasket.
- Re-attach the valve cover.

##### NOTE:

**Start all four screws before tightening or you will not be able to get all the screws in place. Make sure the valve cover gasket is in place.**

- Re-attach the spark plug wire to the spark plug.
- Repeat the process for the other cylinder.

#### 4.9 COOLING SYSTEM

Air inlet and outlet openings in the generator compartment must be open and unobstructed for continued proper operation. This includes such obstructions as high grass, weeds, brush, leaves and snow.

Without sufficient cooling and ventilating air flow, the engine/generator quickly overheats, which causes it to quickly shut down. (See Figure 4.9 for vent locations.)

Figure 4.9 – Cooling Vent Locations

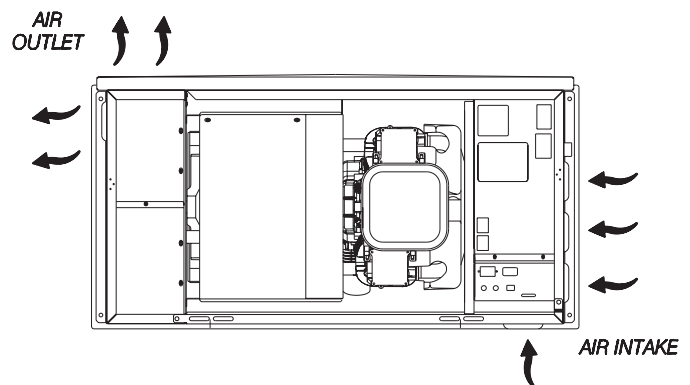

##### WARNING

- ⚠ The exhaust from this product gets extremely hot and remains hot after shutdown. High grass, weeds, brush, leaves, etc. must remain clear of the exhaust. Such materials may ignite and burn from the heat of the exhaust system.

##### CAUTION

- ⚠ The maximum ambient temperature for your generator is 48.9° C (104° F).

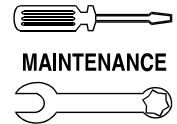

## 4.10 ATTENTION AFTER SUBMERSION

If the generator has been submerged in water, it **MUST NOT** be started and operated. Following any submersion in water, have a Generac Authorized Dealer thoroughly clean and dry the generator.

## 4.11 CORROSION PROTECTION

Periodically wash and wax the enclosure using automotive type products. Frequent washing is recommended in salt water/coastal areas. Spray engine linkages with a light oil such as WD-40.

## 4.12 OUT OF SERVICE PROCEDURE

### ◆ 4.12.1 REMOVAL FROM SERVICE

If you cannot exercise the generator every seven days, and it is to be out of service longer than 90 days, prepare the generator for storage as follows:

1. Start the engine and let it warm up.
2. Close the fuel shutoff valve in the fuel supply line and allow the unit to shut down.
3. Once the unit has shut down, it will signal a low oil fault.
4. Set the Auto/Off/Manual switch to OFF and turn off the utility power to the transfer switch. Remove both fuses from the generator control panel.
5. While the engine is still warm from running, drain the oil completely. Refill the crankcase with oil. See "Engine Oil Recommendations," Section 4.3.1 (Page 17).
6. Attach a tag to the engine indicating the viscosity and classification of the oil in the crankcase.
7. Remove the spark plug(s) and spray fogging agent into the spark plug(s) threaded openings. Reinstall and tighten the spark plug(s).
8. Remove the battery and store it in a cool, dry room on a wooden board. Never store the battery on any concrete or earthen floor.
9. Clean and wipe the entire generator.

### ◆ 4.12.2 RETURN TO SERVICE

To return the unit to service after storage, proceed as follows:

1. Set the generator's main circuit breaker to its OFF (or open) position.
2. Verify that utility power is turned off and that the Auto/Off/Manual switch is set to OFF.
3. Check the tag on the engine for oil viscosity and classification. Verify that the correct recommended oil is used in the engine (see Section 4.3.1, Page 17). If necessary, drain and refill with the proper oil.
4. Check the state of the battery. Fill all cells of unsealed batteries to the proper level with distilled water. **DO NOT USE TAP WATER IN THE BATTERY.** Recharge the battery to 100 percent state of charge, or, if defective, replace the battery. See "Specifications," Section 1.5 (Page 6), for type and size.
5. Clean and wipe the entire generator.
6. Remove both fuses from the generator control panel.
7. Reconnect the battery. Observe battery polarity. Damage may occur if the battery is connected incorrectly. Replace the fuses in the generator control panel.
8. Open the fuel shutoff valve.
9. Start the unit by moving the Auto/Off/Manual switch to MANUAL. Allow the unit to warm up thoroughly.
10. Stop the unit and set the Auto/Off/Manual switch to AUTO. Set the generator's main circuit breaker to its ON (or closed) position.
11. Turn on the utility power to the transfer switch.
12. Your generator is now ready for service.

#### **NOTE:**

**If the battery was dead or disconnected, you must reset the exercise timer.**

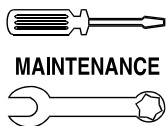

MAINTENANCE

**Section 4 – Maintenance**

**Guardian Air-cooled 7 kW, 12 kW and 15 kW Generators**

**4.13 SERVICE SCHEDULE**

**ATTENTION: It is recommended that all service work be performed by your nearest Generac Authorized Dealer.**

<b>SYSTEM/COMPONENT</b>	<b>PROCEDURE</b>			<b>FREQUENCY</b>
X = Action R = Replace as Necessary * = Notify Dealer if Repair is Needed.	Inspect	Change	Clean	W = Weekly M = Monthly Y = Yearly
<b>FUEL</b>				
Fuel lines and connections*	X			M
<b>LUBRICATION</b>				
Oil level	X			M
Oil		X		AFTER BREAK-IN, AND Y
Oil filter		X		AFTER BREAK-IN, AND Y
<b>COOLING</b>				
Enclosure louvers	X		X	W
<b>BATTERY</b>				
Remove corrosion, ensure dryness	X		X	M
Clean and tighten battery terminals	X		X	M
Check charge state	X	R		EVERY 6 M
Electrolyte level (unsealed batteries only)*	X	R		EVERY 6 M
<b>ENGINE AND MOUNTING</b>				
Air cleaner	X	R		Y
Spark plug(s)	X	R		Y
<b>GENERAL CONDITION</b>				
Vibration, Noise, Leakage, Temperature*	X			M
<b>COMPLETE TUNE-UP*</b>	TO BE COMPLETED BY A GENERAC AUTHORIZED DEALER			Y





## 5.1 TROUBLESHOOTING GUIDE

PROBLEM	CAUSE	CORRECTION
The engine will not crank.	<ol style="list-style-type: none"> <li>1. Fuse blown</li> <li>2. Loose, corroded or defective battery cables</li> <li>3. Defective starter contactor (7 kW)</li> <li>4. Defective starter motor</li> <li>5. Dead Battery</li> </ol>	<ol style="list-style-type: none"> <li>1. Replace 15A fuse on generator control panel.</li> <li>2. Tighten, clean or replace as necessary.</li> <li>3. *</li> <li>4. *</li> <li>5. Charge or replace battery.</li> </ol>
The engine cranks but will not start.	<ol style="list-style-type: none"> <li>1. Out of fuel</li> <li>2. Defective fuel solenoid (FS)</li> <li>3. Open #14 wire from engine control board</li> <li>4. Defective spark plug(s)</li> <li>5. Valve lash out of adjustment.</li> </ol>	<ol style="list-style-type: none"> <li>1. Replenish fuel.</li> <li>2. *</li> <li>3. *</li> <li>4. Clean, re-gap or replace plug(s).</li> <li>5. Reset valve lash.</li> </ol>
The engine starts hard and runs rough.	<ol style="list-style-type: none"> <li>1. Air cleaner plugged or damaged</li> <li>2. Defective spark plug(s)</li> <li>3. Fuel regulator not set.</li> <li>4. Fuel pressure incorrect.</li> </ol>	<ol style="list-style-type: none"> <li>1. Check, replace air cleaner.</li> <li>2. Clean, re-gap or replace plug(s).</li> <li>3. Set fuel regulator.</li> <li>4. Confirm fuel pressure is at 11"-14" water column (0.4 psi - 0.5 psi).</li> </ol>
The Auto/Off/Manual switch is set to OFF, but the engine continues to run.	<ol style="list-style-type: none"> <li>1. Defective switch</li> <li>2. Auto/Off/Manual switch wired incorrectly</li> <li>3. Defective control board</li> </ol>	<ol style="list-style-type: none"> <li>1. *</li> <li>2. *</li> <li>3. *</li> </ol>
There is no AC output from the generator.	<ol style="list-style-type: none"> <li>1. Main line circuit breaker open</li> <li>2. Generator internal failure</li> </ol>	<ol style="list-style-type: none"> <li>1. Reset circuit breaker to ON (or closed).</li> <li>2. *</li> </ol>
There is no transfer to standby after utility source failure.	<ol style="list-style-type: none"> <li>1. Defective transfer switch coil</li> <li>2. Defective transfer relay</li> <li>3. Transfer relay circuit open</li> <li>4. Defective control logic board</li> </ol>	<ol style="list-style-type: none"> <li>1. *</li> <li>2. *</li> <li>3. *</li> <li>4. *</li> </ol>
Unit consumes large amounts of oil.	<ol style="list-style-type: none"> <li>1. Break-in procedure not followed (see Section 3.1)</li> </ol>	<ol style="list-style-type: none"> <li>1. *</li> </ol>

**\*Contact your nearest Generac Authorized Dealer for assistance.**

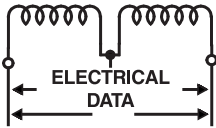

## Section 6 – Electrical Data

### Guardian Air-cooled 7 kW, 12 kW and 15 kW Generators Wiring Diagram – 12 & 15 kW – Drawing No. 0D8500-B

#### DIAGRAM KEY

- BA - BRUSH ASSEMBLY
- BCR - BATTERY CHARGE RELAY
- CB1 - MAIN OUTPUT BREAKER
- CB2 - CIRCUIT BREAKER, ALTERNATOR EXCITATION
- D - DIODE
- DSW - PCB MOUNTED DIP SWITCH
- FS - FUEL SOLENOID
- F1 - FUSE 15 AMP
- F2 - FUSE 5 AMP
- GRD - CONTROL PANEL GROUND
- HTO - HIGH OIL TEMPERATURE SWITCH
- IC - IN-LINE CONNECTOR
- ICT - INTERCONNECTION TERMINALS
- IM1 - IGNITION MODULE, CYLINDER #1
- IM2 - IGNITION MODULE, CYLINDER #2
- LOP - LOW OIL PRESSURE SWITCH
- SC - STARTER CONTACTOR
- SCR - STARTER CONTACTOR RELAY
- SP1, SP2 - SPARK PLUGS
- SW1 - AUTO / OFF / MANUAL SWITCH
- SW2 - SET EXERCISE SWITCH
- SM - STARTER MOTOR
- TB - INSULATED TERMINAL BLOCK
- TX - TRANSFORMER, 16 Vac 56 VA & 16 Vac 1 VA (DUAL SEC.)

#### ENGINE WIRING

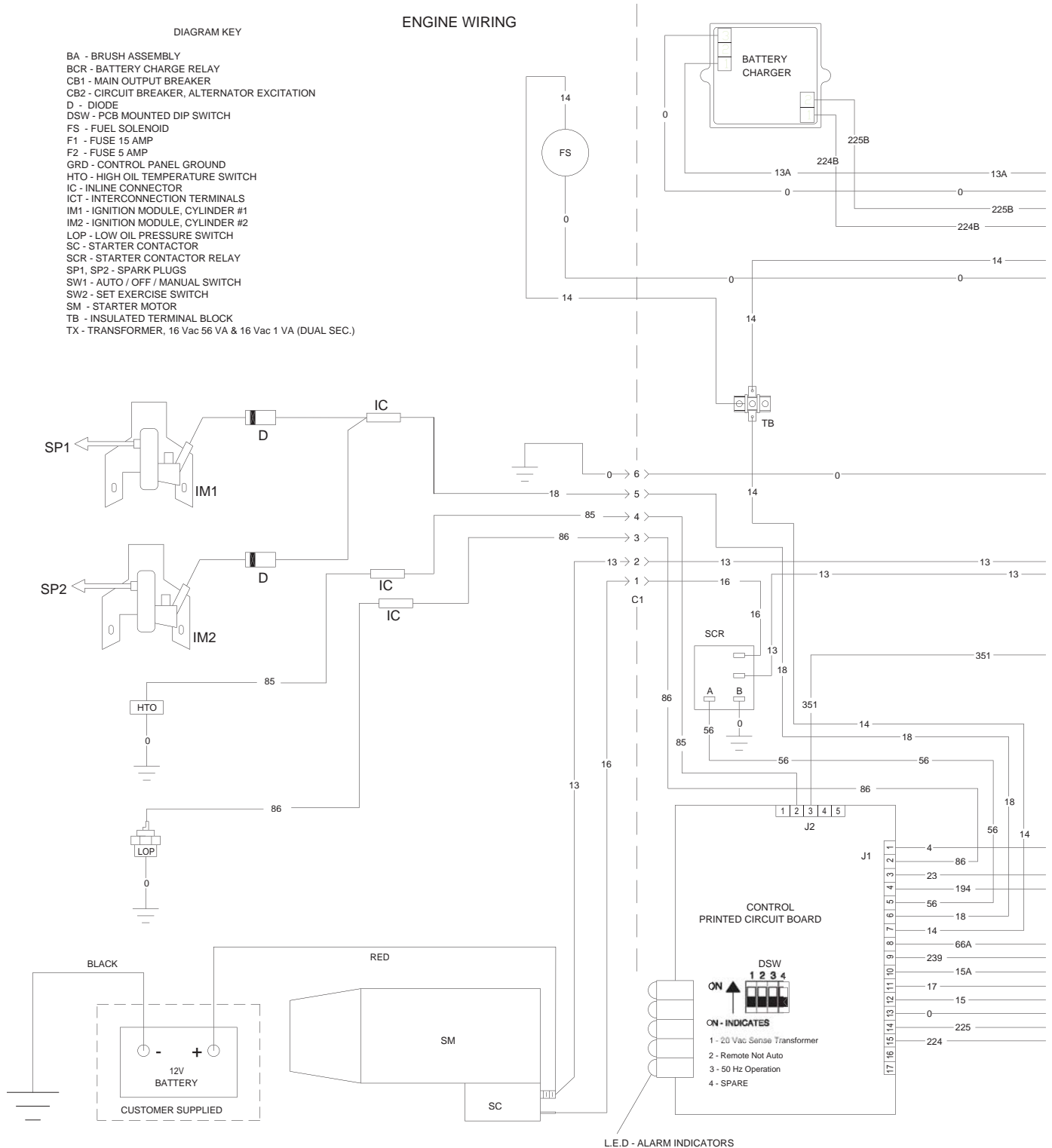

**Section 6 – Electrical Data**  
**Guardian Air-cooled 7 kW, 12 kW and 15 kW Generators**  
**Wiring Diagram – 12 & 15 kW – Drawing No. 0D8500-B**

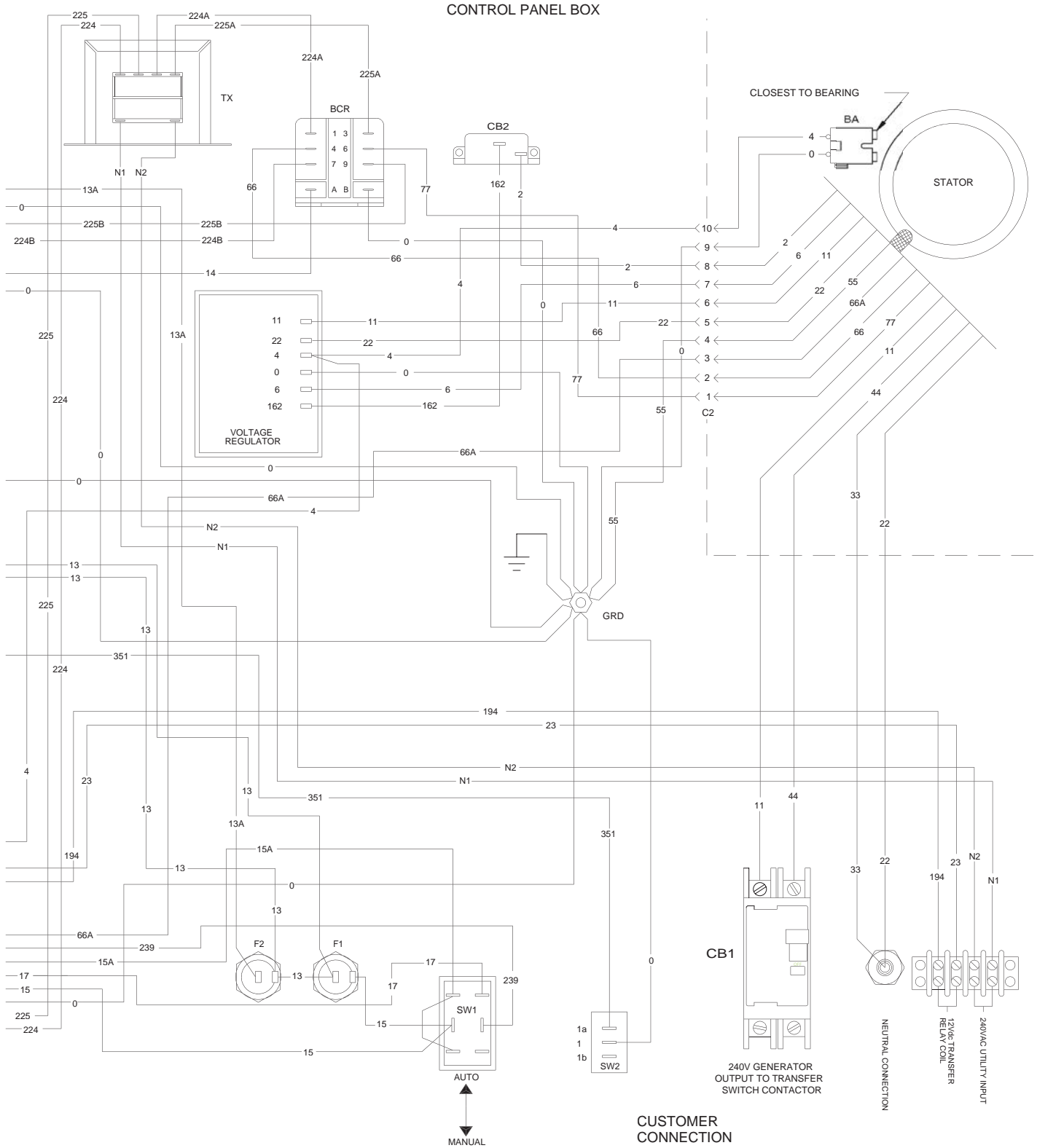
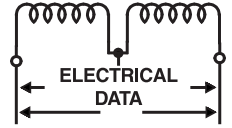

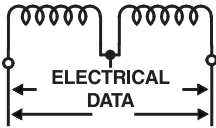

## Section 6 – Electrical Data

### Guardian Air-cooled 7 kW, 12 kW and 15 kW Generators Electrical Schematic – 12 & 15 kW – Drawing No. OD8501-B

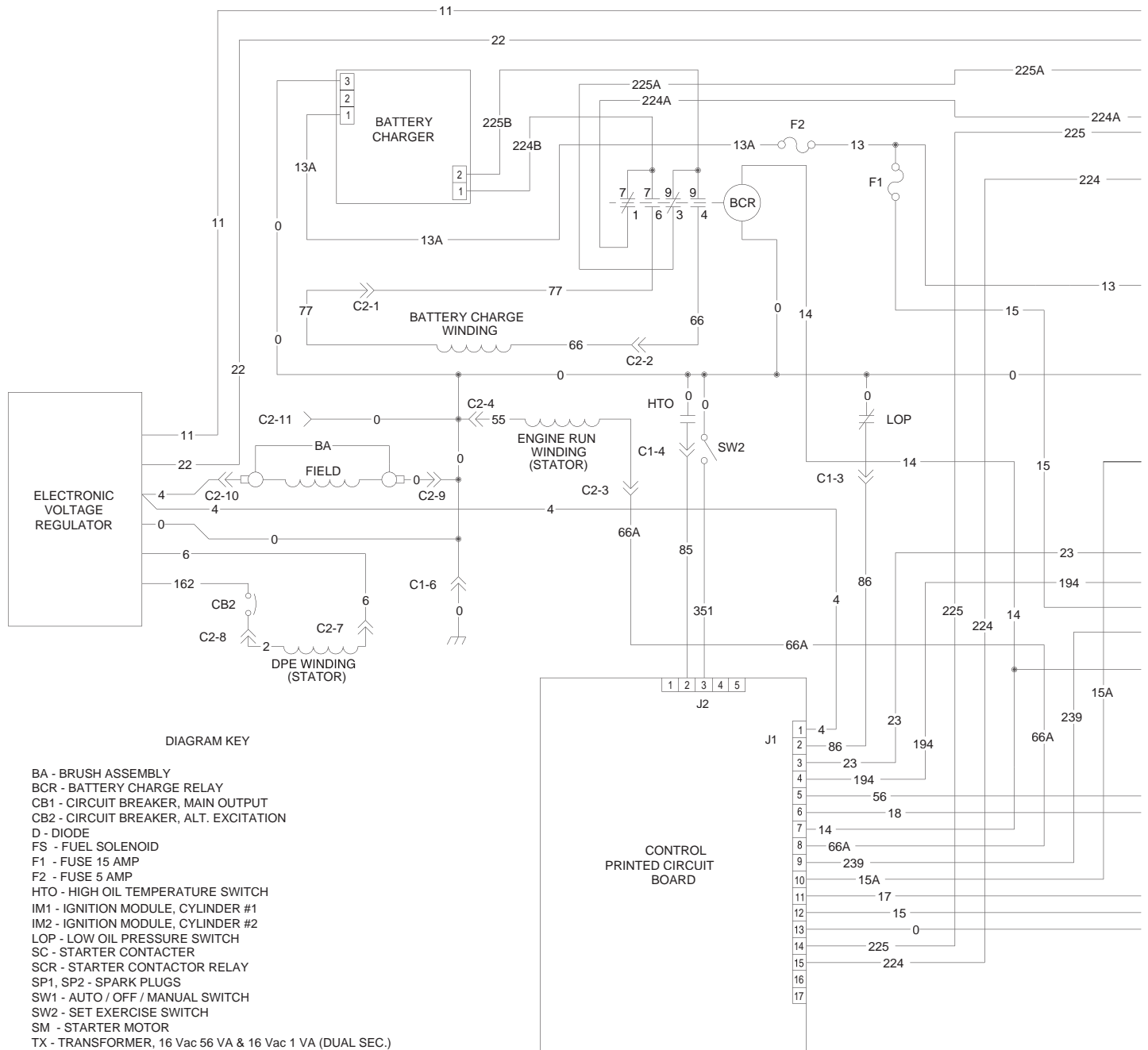

## Section 6 – Electrical Data

### Guardian Air-cooled 7 kW, 12 kW and 15 kW Generators Electrical Schematic – 12 & 15 kW – Drawing No. 0D8501-B

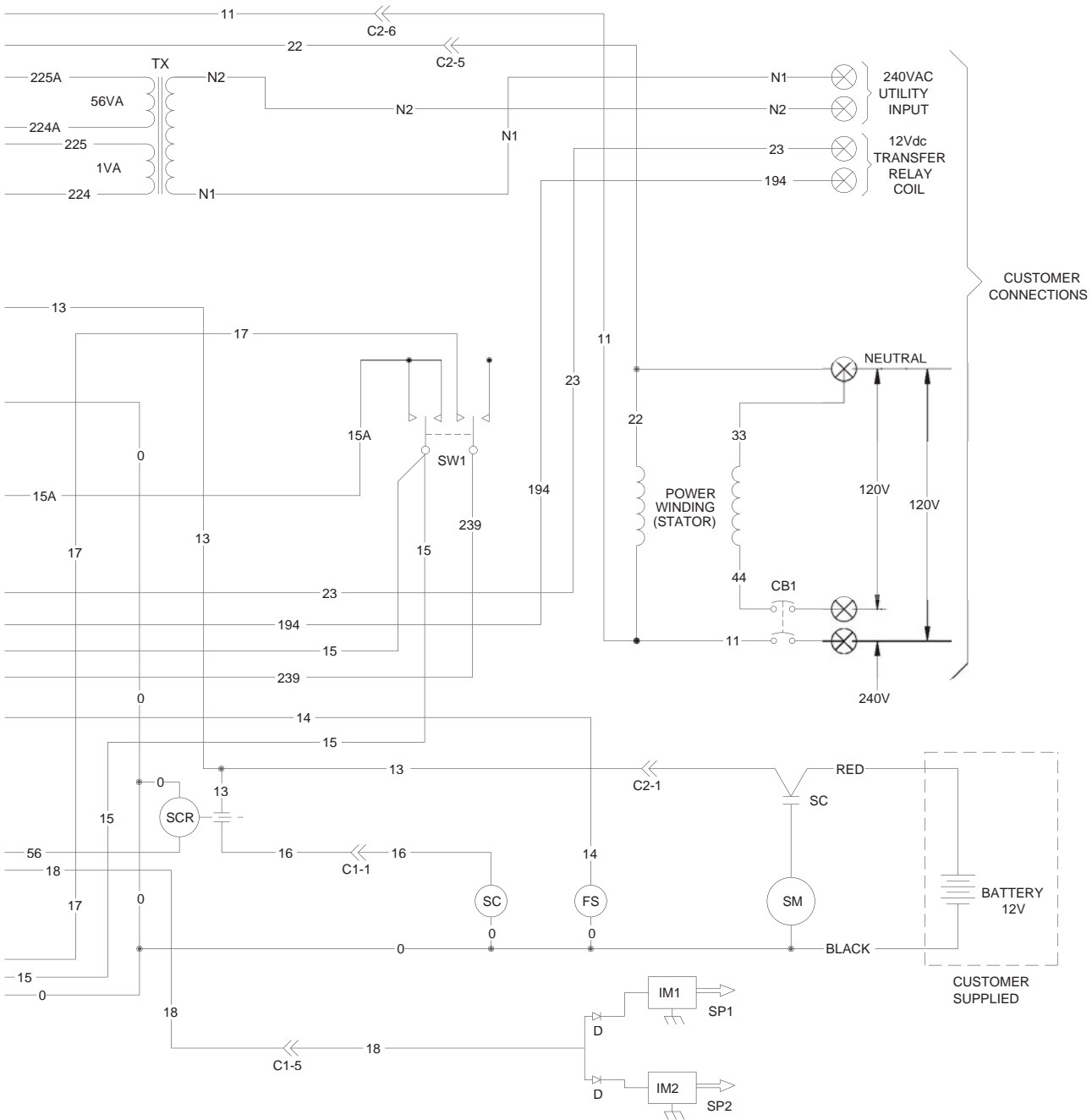
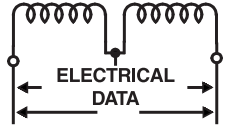

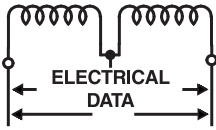

## Section 6 – Electrical Data

### Guardian Air-cooled 7 kW, 12 kW and 15 kW Generators Wiring Diagram – 7 kW – Drawing No. 0D9013-C

#### DIAGRAM KEY

- BA - BRUSH ASSEMBLY
- BCR - BATTERY CHARGE RELAY
- CB1 - MAIN OUTPUT BREAKER
- CB2 - CIRCUIT BREAKER, ALTERNATOR EXCITATION
- D - DIODE
- DSW - PCB MOUNTED DIP SWITCH
- FS - FUEL SOLENOID
- F1 - FUSE 15 AMP
- F2 - FUSE 5 AMP
- GRD - CONTROL PANEL GROUND
- HTO - HIGH OIL TEMPERATURE SWITCH
- IC - IN-LINE CONNECTOR
- ICT - INTERCONNECTION TERMINALS
- IM - IGNITION MODULE
- LOP - LOW OIL PRESSURE SWITCH
- SC - STARTER CONTACTOR
- SP - SPARK PLUG
- SW1 - AUTO / OFF / MANUAL SWITCH
- SW2 - SET EXERCISE SWITCH
- SM - STARTER MOTOR
- TB - INSULATED TERMINAL BLOCK
- TX - TRANSFORMER, 16 Vac 56 VA & 16 Vac 1 VA (DUAL SEC.)

#### ENGINE WIRING

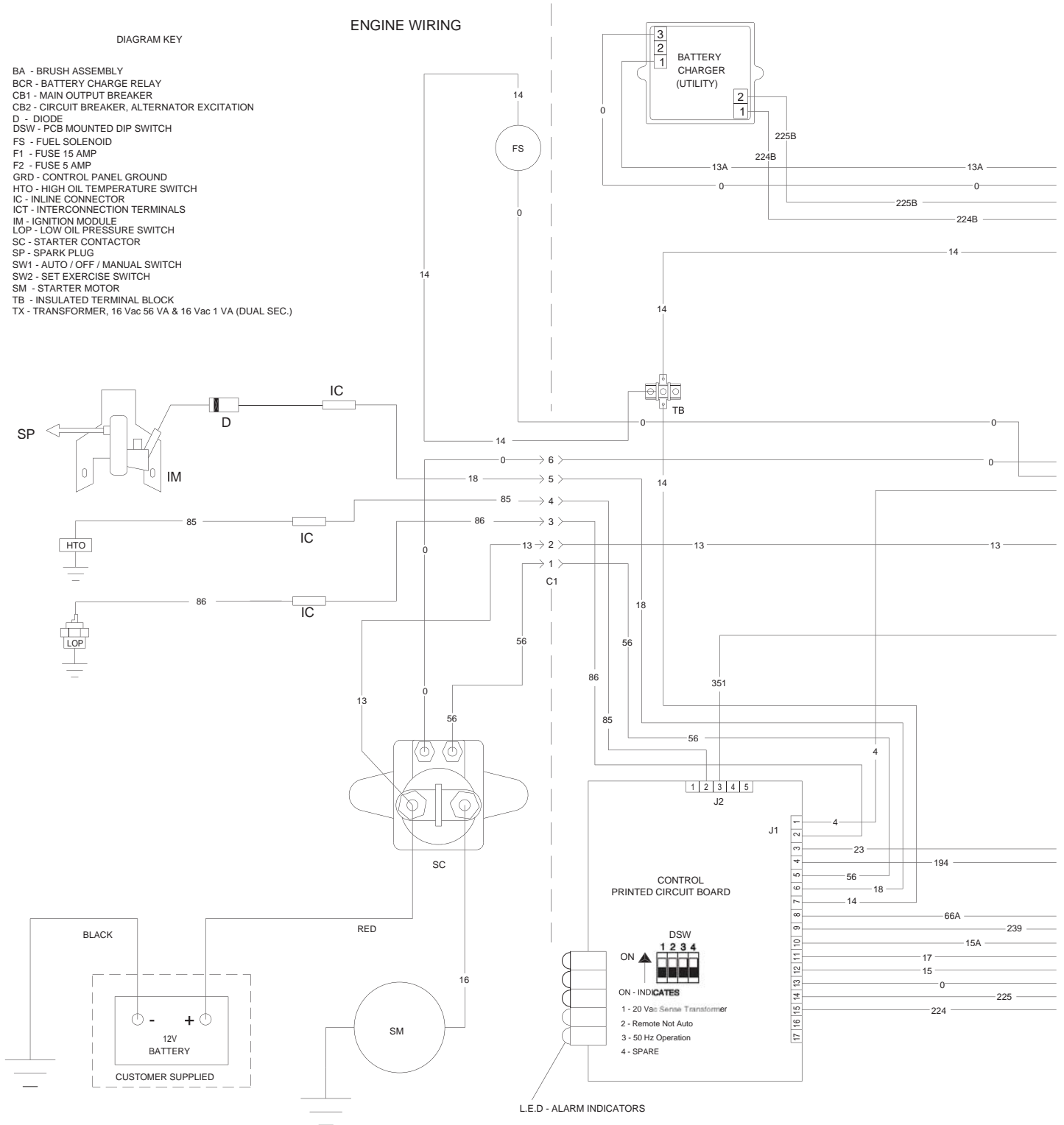

**Section 6 – Electrical Data**  
**Guardian Air-cooled 7 kW, 12 kW and 15 kW Generators**  
**Wiring Diagram – 7 kW – Drawing No. 0D9013-C**

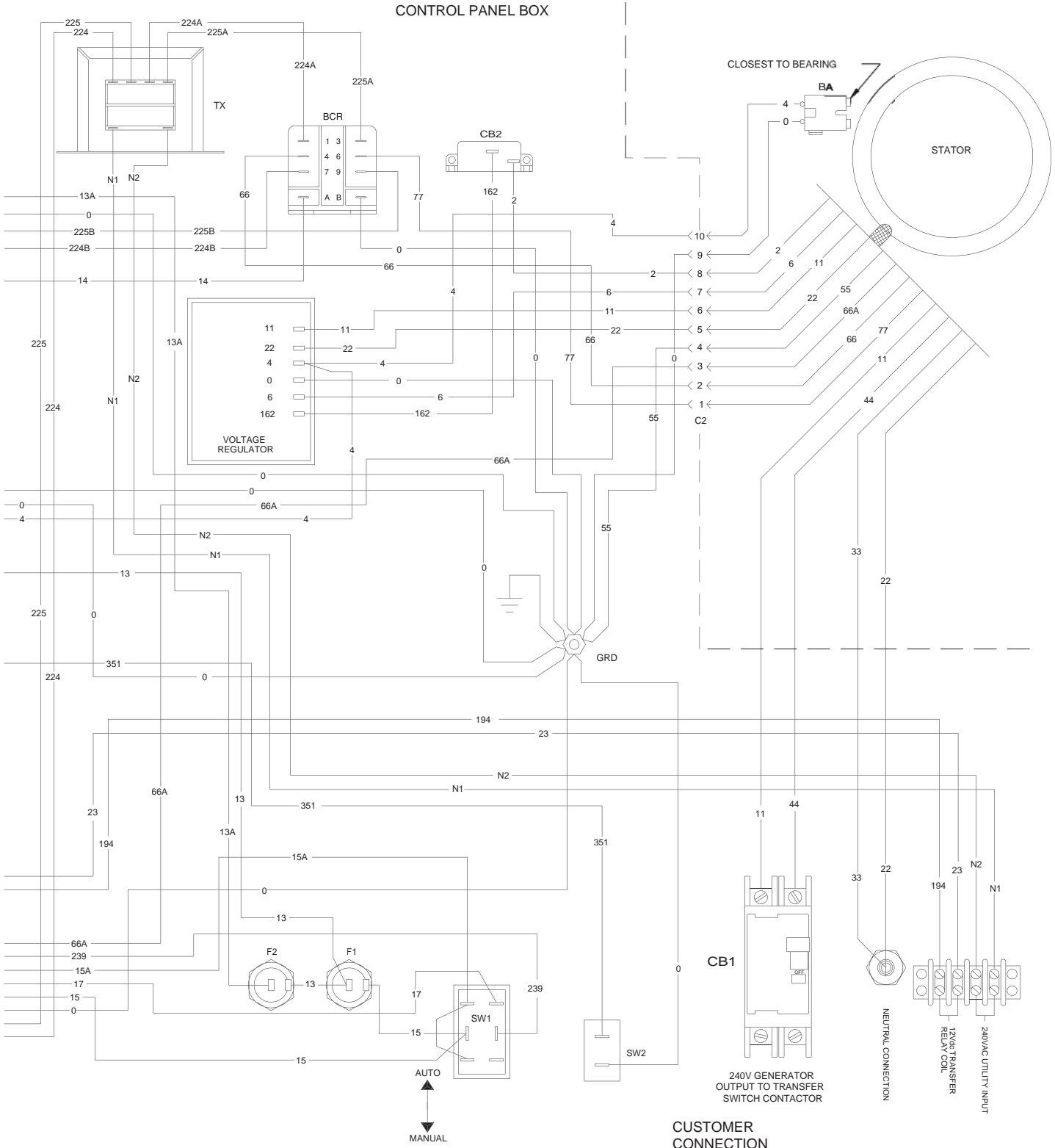
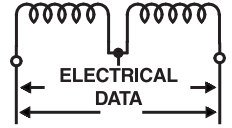

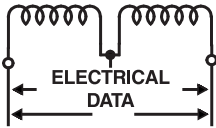

**Section 6 – Electrical Data**

**Guardian Air-cooled 7 kW, 12 kW and 15 kW Generators  
Electrical Schematic – 7 kW – Drawing No. 0D9014-C**

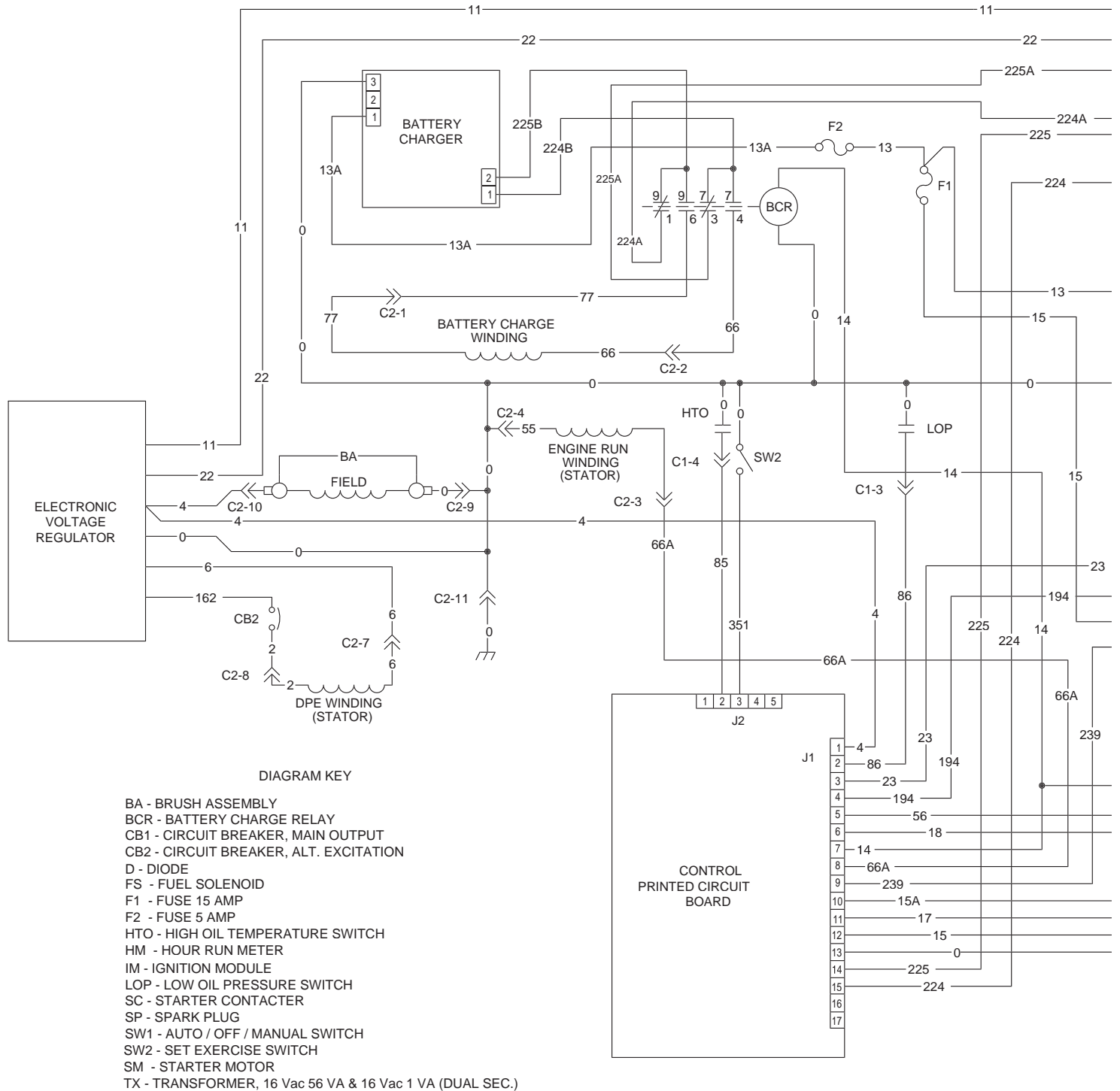





**Section 7 – Exploded Views and Parts Lists**  
**Guardian Air-cooled 7 kW, 12 kW and 15 kW Generators**  
**Enclosure – Drawing No. 0D3416-R**

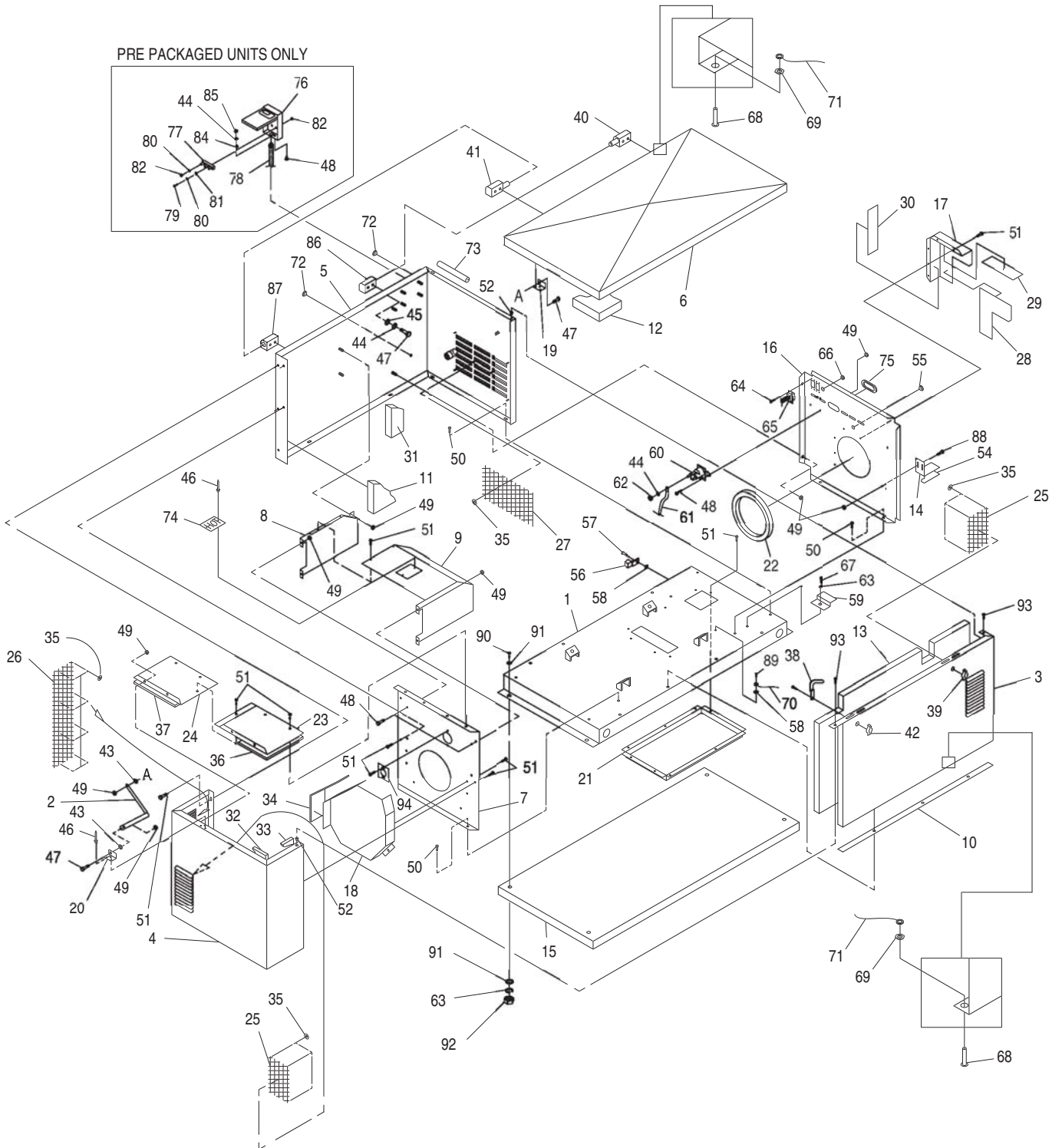

**Section 7 – Exploded Views and Parts Lists**  
**Guardian Air-cooled 7 kW, 12 kW and 15 kW Generators**  
**Enclosure – Drawing No. 0D3416-R**

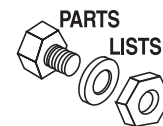

ITEM	PART NO.	QTY.	DESCRIPTION	ITEM	PART NO.	QTY.	DESCRIPTION
1	0C6140	1	ASSEMBLY, ENCLOSURE BASE	44	022097	9	WASHER LOCK M6-1/4"
	0D1901	1	ASSEMBLY, ENCLOSURE BASE (7KW)	45	022473	4	WASHER FLAT 1/4" ZINC
2	0C6735	2	SUPPORT, ROOF FOLDING	46	036261	14	RIVET POP .125 X .129-.133/#30
3	0C7061	1	ENCLOSURE, FRONT	47	047411	12	SCREW HHC M6-1.0 X 16 G8.8
4	0C7062	1	ENCLOSURE, EXHAUST SIDE	48	043116	5	SCREW HHC M6-1.0 X 12 G8.8
	0C7062A	1	ENCLOSURE, EXHAUST SIDE (7KW)		043116	6	SCREW HHC M6-1.0 X 12 G8.8 (7KW)
5	0C7063	1	ENCLOSURE, SIDE & BACK	49	0D3700	18	NUT, LOCKING FLANGE M6-1.0
	0C7063A	1	ENCLOSURE, SIDE & BACK (7KW)	50	083512	11	SCREW TAPTITE M8-1.25 X 16 BP
6	0C7064	1	ENCLOSURE, ROOF	51	090388	36	SCREW TAPTITE M6-1.0 X 12 BP
7	0C7065	1	PANEL, ALTERNATOR DIVIDER			24	SCREW TAPTITE M6-1.0 X 12 BP (7KW)
	0C7065A	1	PANEL, ALTERNATOR DIVIDER (7KW)	52	092120	2	NUT LOCK TRIC M6 X 1.0 Y/ZNC
8	0C8101A	1	PANEL, MUFFLER BOX SIDE	54	0D3167	1	GASKET, BATTERY SUPPORT BRACKET
	0C8861	1	PANEL, MUFFLER BOX SIDE (7KW)	55	0A3328	1	PLUG, PLASTIC 0.593
9	0C8101B	1	COVER, MUFFLER BOX	56	055414	1	LUG SLDLSS #2-#8X17/64 CU
	0C8862	1	COVER, MUFFLER BOX (7KW)	57	092079	1	SCREW TAPTITE M6-1.0X25 BP
10	0C8283	1	GASKET, DOOR SEAL	58	0A1658	2	L/WASH SPECIAL 1/4
11	0C8284A	1	FOAM, BACK ENCLOSURE	59	0C2937	1	BRACKET, BATTERY HOLD DOWN (7KW)
12	0C8284B	1	FOAM, ROOF ENCLOSURE	60	086729	1	CONTACTOR, STARTER (7KW)
13	0C8284C	1	FOAM, FRONT ENCLOSURE	61	0388040AJ0	1	CABLE, #6 RED BATTERY 38.5"
14	0C8285	1	BRACKET, BATTERY SUPPORT	62	022127	2	NUT HEX 1/4-20 STEEL (7KW)
15	0C8899A	1	PAD, 24"X48" WITH MOUNTING HOLES	63	022129	4	WASHER LOCK 5/16
16	0D1128	1	PANEL, ENGINE DIVIDER		022129	5	WASHER LOCK 5/16 (7KW)
	0D1128A	1	PANEL, ENGINE DIVIDER (7KW)	64	074908	8	SCREW TAPTITE M5-0.8 X 10 BP
17	0E4244	1	BAFFLE, INTAKE	65	0D2346	1	HARNESS, ENGINE
	0D1605A	1	BAFFLE, INTAKE (7KW)		0D2345	1	HARNESS, ENGINE (7KW)
18	0D1606	1	HOUSING, FAN	66	023484F	1	BUSHING, SNAP SB-1000-12
	0D5264	1	BAFFLE, EXHAUST (7KW)	67	022142	1	SCREW HHC 5/16-18 X 3/4 G5 (7KW)
19	0D1839	2	BRACKET, TOP SUPPORT	68	0A7836	2	RIVET, 1/8" X 0.126" - 0.375" LSH POP
20	0D1840	2	BRACKET, BOTTOM SUPPORT	69	0A8475	2	L/WASH SPECIAL #10
21	0D2425	1	DUCT, BASE AIR	70	0912970069	1	ASSEMBLY, ROOF / DOOR GROUND WIRE
22	0D2588	1	GASKET, FRONT DIVIDER	71	0912970070	2	ASSEMBLY, ROOF / DOOR GROUND WIRE
	0D2588A	1	GASKET, FRONT DIVIDER (7KW)	72	055450	2	PLUG PLASTIC 1.375
23	0D2676	1	COVER, FRONT EXHAUST ENCLOSURE	73	0D2023	10.5	GASKET, CLIP-ON SELF GRIPPING
24	0D2677	1	COVER, BACK EXHAUST ENCLOSURE	74	0D3701	1	PLATE, "HOT"
25	0D2979B	2	CLOTH, HARDWARE 266.7mm x 146mm	75	0D3472	1	GROMMET 2.75 X 1/16
	0D2979B	3	CLOTH, HARDWARE 266.7mm x 146mm (7KW)	76	0C8742	1	EXTERNAL CONNECTION BOX
26	0D2979C	1	CLOTH, HARDWARE 543mm x 146mm	77	0C8911	1	POWER BLOCK
27	0D2979D	1	CLOTH, HARDWARE 266.7mm x 387.4mm	78	0D8442	1	HARNESS GENERATOR TO EXTERNAL CONNECTION BOX
	0D2979E	1	CLOTH, HARDWARE (7KW)		0D8652	1	HARNESS GENERATOR TO EXTERNAL CONNECTION BOX (7KW)
28	0E4245	1	FOAM, FRONT INTAKE BAFFLE	79	036937	2	SCREW PPHM #10-32 X 1
	0D3058A	1	FOAM, FRONT INTAKE BAFFLE (7KW)	80	022152	5	WASHER LOCK #10
29	0E4245A	1	FOAM, TOP INTAKE BAFFLE	81	051713	2	WASHER FLAT M5
30	0E4245B	1	FOAM, BACK INTAKE BAFFLE	82	022158	5	NUT HEX #10-32 STEEL
	0D3058C	1	FOAM, BACK INTAKE BAFFLE (7KW)	83	0D3031	1	FUEL LINE, 3/4"OUTDOOR (NOT SHOWN)
31	0D3057D	1	FOAM, BACK ENCL. STRIP	84	026850	1	WASHER SHAKPROOF EXT 1/4 STEEL
32	0D3059A	1	FOAM, EXHAUST SIDE ENCLOSURE END	85	049813	1	NUT HEX M6-1.0 G8 YELLOW CHROME
33	0D3059B	1	FOAM, EXHAUST SIDE ENCLOSURE FRONT	86	0D2537A	1	HINGE, LIFT OFF, TYPE A KNUCKLE
34	0D3059C	1	FOAM, EXHAUST FAN HOUSING	87	0D2538A	1	HINGE, LIFT OFF, TYPE B KNUCKLE
35	0D7176	24	WASHER, SELF LOCKING	88	047411	2	SCREW HHC M6-1.0 X 16 G8.8
		22	WASHER, SELF LOCKING (7KW)	89	0A2311	1	SCREW SWAGE 1/4-20 X 1
36	0D3059D	1	FOAM, FRONT EXHAUST ENCLOSURE COVER	90	043107	4	SCREW HHC M8-1.25 X 25
37	0D3059E	1	FOAM, BACK EXHAUST ENCLOSURE COVER	91	022145	8	WASHER FLAT 5/16
38	0C7781	2	DOOR, PAWL	92	045771	4	NUT HEX M8-1.25
39	0D3037	1	LATCH, QUARTER TURN LOCKING	93	0C3906	2	SELF-ALIGN SCREW M6 HH
40	0D2537	1	HINGE, LIFT OFF, TYPE A PIN	94	0E4321	1	PANEL, EXHAUST ALIGNMENT
41	0D2538	1	HINGE, LIFT OFF, TYPE B PIN				
42	0D3037A	1	LATCH, QUARTER TURN NON-LOCKING				
43	0A2115	4	WASHER NYLON .250"				

**Section 7 – Exploded Views and Parts Lists**

**Guardian Air-cooled 7 kW, 12 kW and 15 kW Generators  
Control Panel – Drawing No. 0D8503-F**

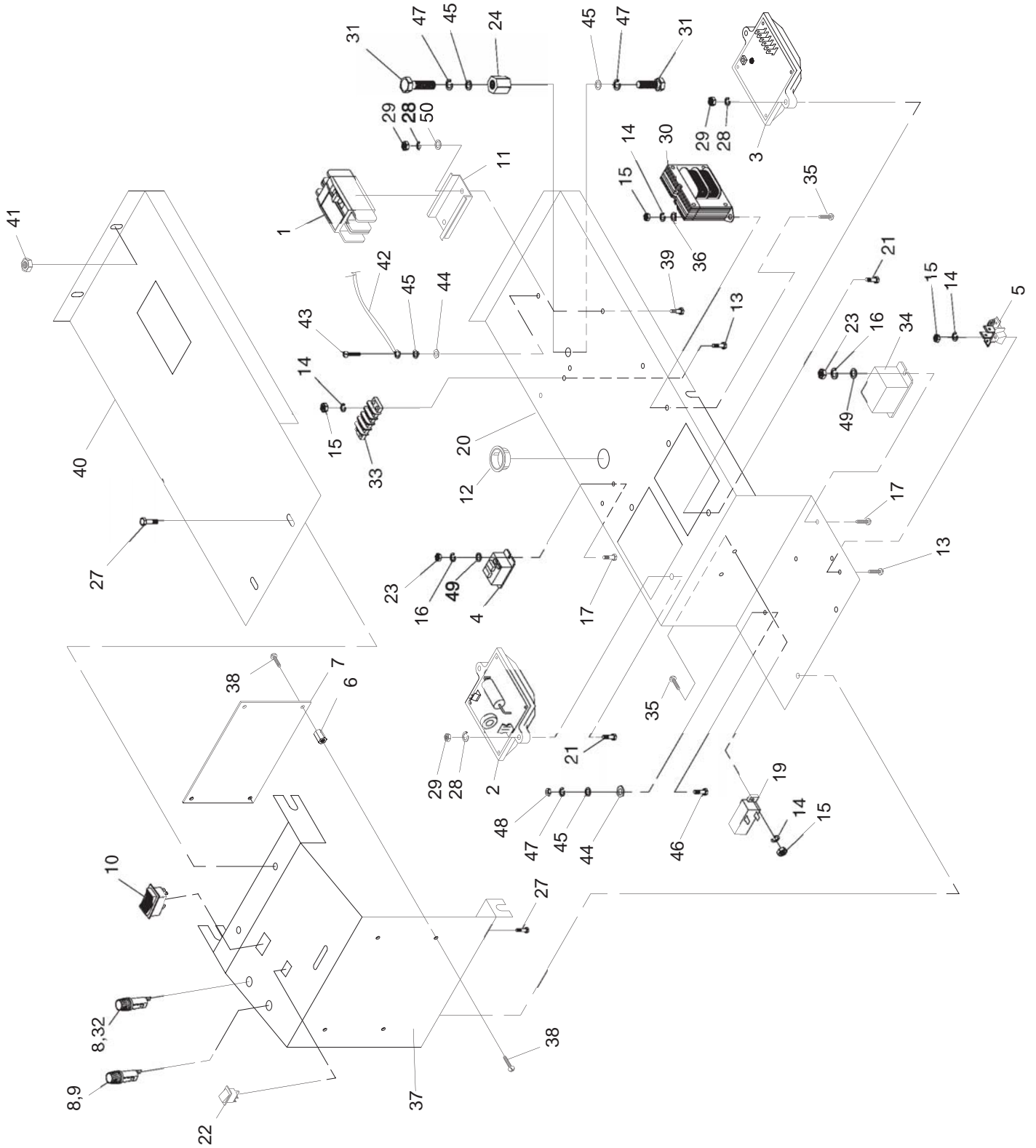

**Section 7 – Exploded Views and Parts Lists**  
**Guardian Air-cooled 7 kW, 12 kW and 15 kW Generators**  
**Control Panel – Drawing No. 0D8503-F**

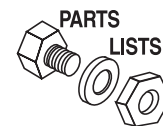

ITEM	PART NO.	QTY.	DESCRIPTION	ITEM	PART NO.	QTY.	DESCRIPTION
1	0A9947E	1	CIRCUIT BREAKER 30 X 2 240V SQD QOU230 (7KW)	23	051714	4	NUT HEX M3-0.5 (8.5KW/ 12KW/ 13KW)
	0A9947G	1	CIRCUIT BREAKER 40 X 2 240V SQD QOU240 (8.5KW)		051714	2	NUT HEX M3-0.5 (7KW)
	0A9947F	1	CIRCUIT BREAKER 50 X 2 240V SQD QOU250 (12KW)	24	0D8502	1	NEUTRAL ISOLATOR
	0A9947C	1	CIRCUIT BREAKER 60 X 2 240V SQD QOU260 (13KW)	26	0D8441	1	HARNESS, CONTROL PANEL WIRE (NOT SHOWN) (8.5KW/ 12KW/ 13KW)
	0A9947D	1	CIRCUIT BREAKER 70 X 2 240V SQD QOU260 (15KW)		0E0120	1	HARNESS, CONTROL PANEL WIRE (NOT SHOWN) (7KW)
2	0A1801	1	ASSEMBLY, BATTERY CHARGER ENGINE	27	074908	4	SCREW TAPTITE, M5-0.8 x 10 BP
3	083049	1	ASSEMBLY, POTTED REGULATOR	28	049226	6	WASHER LOCK M5
4	0C2174	1	RELAY, 12V 25A SPST (8.5KW/ 12KW/ 13KW)	29	051716	6	NUT HEX M5-0.8
5	075210A	1	BLOCK 1 POSITION	30	0C3910	1	TRANSFORMER
6	0D3062	4	HEX STAND-OFF #6-32 x 3/8"	31	022507	2	SCREW HHC 1/4"-20 x 1/2"
7	0D8615	1	ASSEMBLY, HOME STANDBY CONTROLLER	32	099727	1	FUSE 5A X AGC5
8	032300	2	HOLDER, FUSE	33	046689	1	TERMINAL STRIP
9	022676	1	FUSE, 15AMP X AGC15	34	063617	1	RELAY PANEL 12VDC DPDT 10A 240VAC
10	0E4494	1	SWITCH, ROCKER	35	075475	4	SCREW PPHM M4-0.7 x 10mm
11	0D5045	1	DIN RAIL	36	043180	2	WASHER FLAT M4
12	023484E	1	SNAP BUSHING SB-687-8	37	0D8439	1	COVER, CONTROL PANEL COMPONENT (8.5KW/ 12KW/ 13KW)
13	075476	4	SCREW PPHM M4-0.7 x 16mm		0E0119	1	COVER, CONTROL PANEL COMPONENT (7KW)
14	022264	8	WASHER LOCK M4	38	092036	8	SCREW PPHMS/LW #6-32 x 1/4"
15	051715	8	NUT HEX M4-0.7	39	045770	2	SCREW HHC M5-0.8 x10mm
16	043182	4	WASHER LOCK M3 (8.5KW/ 12KW/ 13KW)	40	0C7171	1	COVER, CONTROL PANEL (8.5KW/ 12KW/ 13KW)
	043182	2	WASHER LOCK M3 (7KW)		0D2989	1	COVER, CONTROL PANEL (7KW)
17	043181	4	SCREW PHM M3-0.5 x 10mm	41	0D3700	10	NUT FLANGE M6-1.0 NYLOCK
18	0D8443	1	DECAL, CONTROL PANEL (NOT SHOWN)	42	0912970069	1	ASSEMBLY, ROOF/DOOR GROUND WIRE
19	054502	1	CIRCUIT BREAKER 3 X 1 ETA 46-500-P (8.5KW/ 12KW/ 13KW)	43	0A2311	1	SCREW SWAGE 1/4"-20 x 1"
	053623	1	CIRCUIT BREAKER 2.5 X 1 ETA 46-500-P (7KW)	44	0A1658	2	LOCKWASHER SPECIAL 1/4"
	0E0118	1	CONTROL, PANEL BOTTOM (8.5KW/ 12KW/ 13KW)	45	022473	3	WASHER FLAT 1/4"
20	0D8438	1	CONTROL, PANEL BOTTOM (7KW)	46	038750	1	SCREW HHC M6-1.0 x 30mm
	0E0118	1	CONTROL, PANEL BOTTOM (7KW)	47	022097	3	WASHER LOCK M6-1/4"
21	075235	4	SCREW HHC M5-0.8 x 30mm	48	049813	1	NUT HEX M6-1.0
22	0D5240	1	SWITCH, SPDT ON-MOM-ON	49	031879	4	WASHER FLAT #4 (8.5KW/ 12KW/ 13KW)
				50	023897	2	WASHER FLAT #4 (7KW)
						2	WASHER FLAT #10

**Section 7 – Exploded Views and Parts Lists**

**Guardian Air-cooled 7 kW, 12 kW and 15 kW Generators  
GT-990 Engine – Drawing No. 0D8674-F Part 1**

66	2, 5, 19, 20, 39, 40, 47, 64, 93, 140
67	8, 11, 12, 13
68	4, 5, 6
69	16A, 16B, 17, 18
70	7, 47, 48, 49, 50, 51, 52, 53, 54, 56, 57, 58, 59, 60, 63, 64
71	47, 48, 49, 50, 51, 52, 53, 54, 56, 57, 58, 59, 60, 62, 63, 64
72	27, 28, 29
73	3, 32, 33, 34, 35, 36, 40, 72

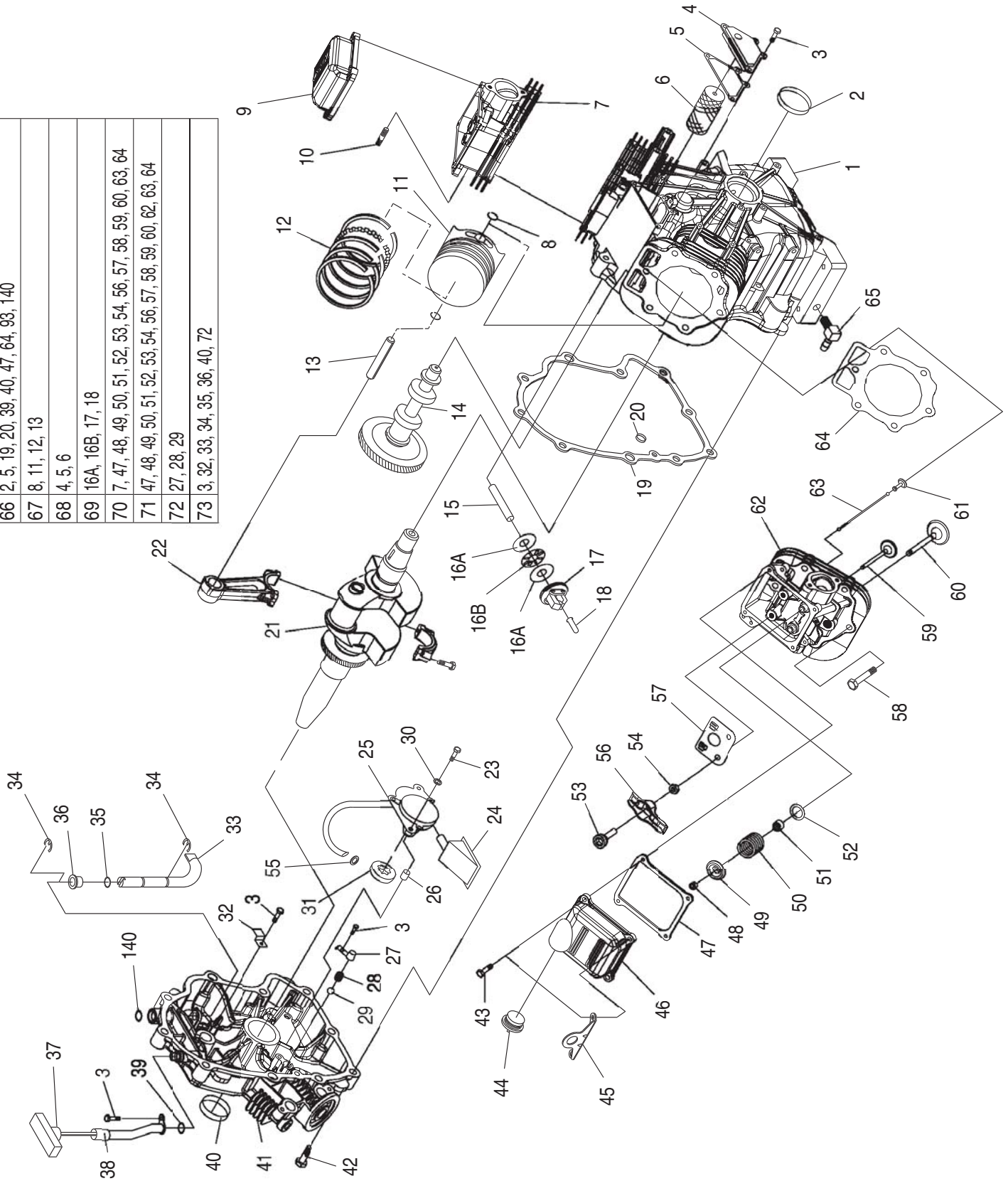

## Section 7 – Exploded Views and Parts Lists

### Guardian Air-cooled 7 kW, 12 kW and 15 kW Generators GT-990 Engine – Drawing No. 0D8674-F Part 1

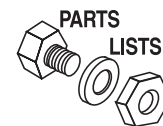

ITEM	PART NO.	QTY.	DESCRIPTION	ITEM	PART NO.	QTY.	DESCRIPTION
1	0C5729	1	ASSEMBLY, CRANKCASE HOUSING WITH SLEEVE	35	0C2988	1	THRUST WASHER, GOVERNOR
2	0C3008	1	SEAL, 38 I.D. CRANKSHAFT	36	0C2992	1	BUSHING, GOVERNOR LOWER
3	090388	8	SCREW, TAPTITE M6-1.0 X 12 YC	37	0C3971C	1	ASSEMBLY, DIPSTICK WITH HANDLE
4	0C5372	1	ASSEMBLY, BREATHER	38	0C5305	1	TUBE, DIPSTICK
5	0C3005	1	GASKET, BREATHER COVER	39	0C3027	1	O-RING, OIL CLR 3/8 X 1/2
6	0E3372B	1	SEPARATOR, OIL BREATHER	40	0C3007	1	SEAL, 42 I.D. CRANKSHAFT
7	0D8067A	1	ASSEMBLY, HEAD #1 G&S	41	0C5731	1	ASSEMBLY, HOUSING COVER WITH SLEEVE
8	071983	4	RETAINER, PISTON PIN 20	42	0C3006	9	SCREW, HHFC M10-1.5 X 55
9	0C2981C	1	ROCKER, COVER NO OIL FILL	43	080318	8	SCREW HHFC M6-1.0 X 25
10	045761A	4	STUD M8-1.25/10MM X 30 G5 ZINC	44	093064	1	ASSEMBLY, OIL FILL CAP
11	0C5848	2	PISTON, HC	45	0C8808	2	HOOK, LIFTING
12	021533	2	SET, PISTON RING 90MM	46	0D2723B	1	ROCKER, COVER WITH OIL FILL
13	071980	2	PIN PISTON D20	47	0C2979	2	GASKET, VALVE COVER
14	0D4041	1	ASSEMBLY, CAMSHAFT & GEAR	48	086515	8	KEEPER, VALVE SPRING
15	0C2983	1	SHAFT, GOVERNOR	49	0D2274	4	RETAINER, VALVE SPRING
16A	0C2985A	2	ROLLER BEARING, GOVERNOR PLATE	50	0D3867	4	SPRING, VALVE
16B	0C2985B	1	ROLLER BEARING, GOVERNOR	51	078672	2	SEAL, VALVE STEM D7
17	0D4042	1	ASSEMBLY, GOVERNOR GEAR	52	0C5371	4	WASHER, VALVE SPRING
18	0A7811	1	SPOOL, GOVERNOR MACHINED	53	072694	4	STUD, ROCKER ARM PIVOT
19	0C2977	1	GASKET, CRANK CASE	54	0D3998	4	NUT HEX M8-1.0 G8 YEL CHR
20	0C5943	1	SEAL, OIL PASSAGE	55	0C3027	2	O-RING, 3/8" X 1/2"
21	0D4040E	1	ASSEMBLY, CRANKSHAFT HORIZONTAL DIRECT DRIVE (GT-990)	56	0D5313	4	ROCKER ARM
	0D4122E	1	ASSEMBLY, CRANKSHAFT HORIZONTAL DIRECT DRIVE (GT-760)	57	0D6024	2	PLATE, PUSH ROD GUIDE
22	0C2969	2	ASSEMBLY, CONNECTING ROD (GT-990)	58	0C2976	12	SCREW HHFC M8-1.25 X 65
	0D3961	2	ASSEMBLY, CONNECTING ROD (GT-760)	59	086516	2	VALVE, EXHAUST
23	0D2157	2	SCREW SHC M6-1.0 X 50 G8.8	60	0C2229	2	VALVE, INTAKE
24	0C5313	1	SCREEN, OIL PICKUP	61	083897	4	TAPPET, SOLID
25	0D4123	1	ASSEMBLY, OIL PUMP	62	0D8067B	1	ASSEMBLY, HEAD #2 G&S
26	078699E	2	SLEEVE, SEAMED DOWEL 10 DIA.	63	0D9853D	4	PUSHROD, 147
27	0C3011	2	COVER, OIL RELIEF	64	0C2978	2	GASKET, HEAD
28	0C3009	2	SPRING, OIL RELIEF	65	043790A	1	BARBED ELBOW 90 3/8NPT X 3/8 LOCKTITE
29	0C3010	2	BALL, 1/2D OIL RELIEF	66	0D4010	1	KIT GASKET
30	093873	2	WASHER, LOCK RIB M6	67	0D4011	1	KIT PISTON & RINGS
31	0C5315	1	GEROTOR, OUTER	68	0D4012	1	KIT BREATHER ASSEMBLY
32	0C5998	1	CLAMP, OIL TUBE	69	0D4013	1	KIT GOVERNOR ASSEMBLY
33	0D1667	1	ARM, GOVERNOR	70	0D8675A	1	KIT HEAD ASSEMBLY CYLINDER 1
34	0C2991	2	E-RING, GOVERNOR ARM	71	0D8675B	1	KIT HEAD ASSEMBLY CYLINDER 2
				72	0D4015	1	KIT OIL RELIEF
				73	0D4016	1	KIT GEAR COVER

**Section 7 – Exploded Views and Parts Lists**  
**Guardian Air-cooled 7 kW, 12 kW and 15 kW Generators**  
**GT-990/760 Engine – Drawing No. 0D8674-F Part 2**

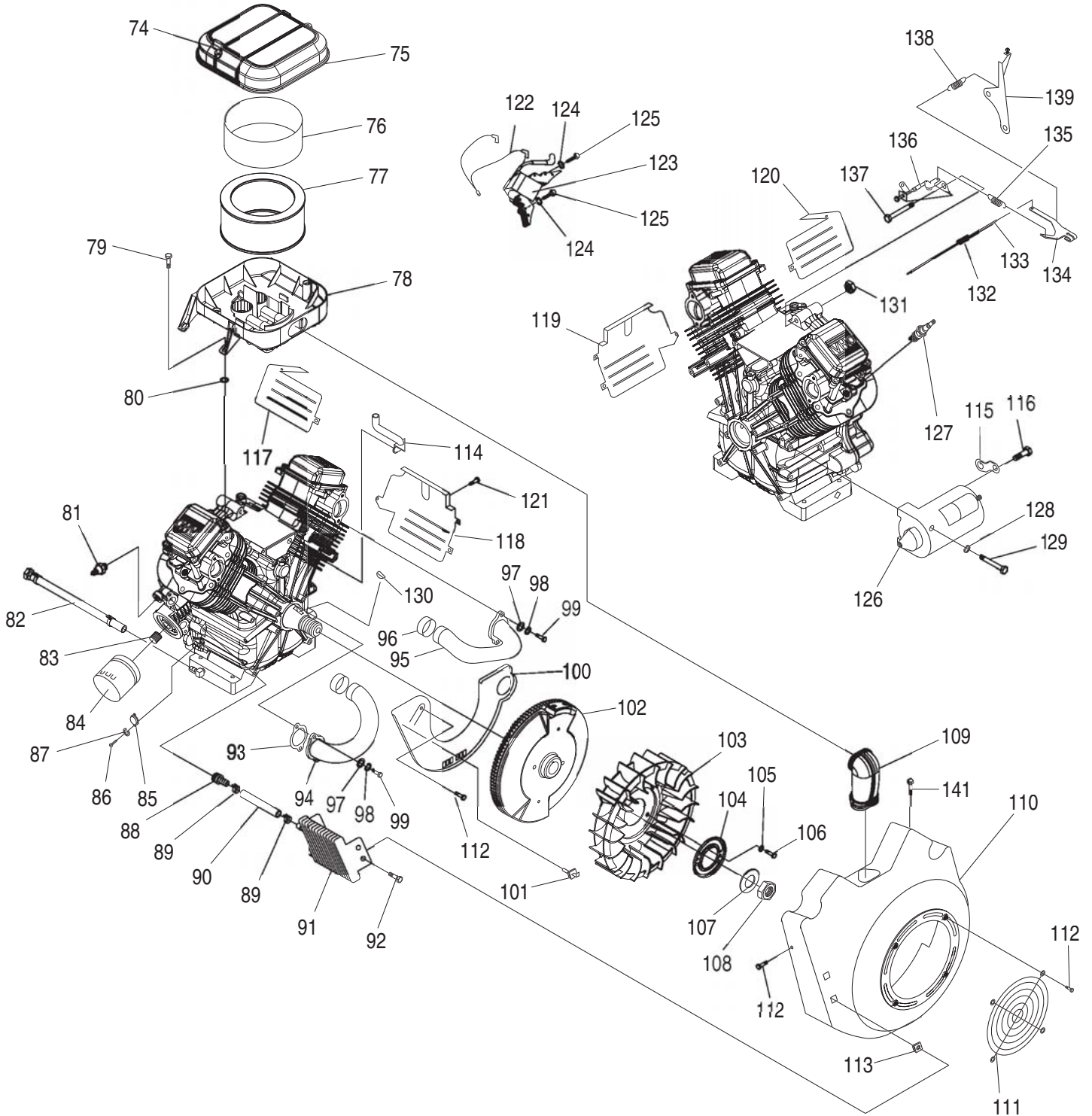



**Section 7 – Exploded Views and Parts Lists**  
**Guardian Air-cooled 7 kW, 12 kW and 15 kW Generators**  
**GT-990/760 Engine – Drawing No. 0D8674-F Part 2**

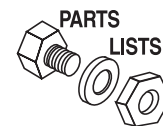

ITEM	PART NO.	QTY.	DESCRIPTION	ITEM	PART NO.	QTY.	DESCRIPTION
74	0C5136A	2	KNOB, AIR CLEANER	109	0C8549	1	SNORKEL, AIR INTAKE
75	0C3024	1	COVER, AIRBOX NG/LP	110	0C3022A	1	HOUSING, BLOWER NG COOLER
76	0C3040	1	PRE-CLEANER,	111	0D1131	1	GUARD, FAN
77	0C8127	1	ELEMENT, AIR CLEANER	112	045756	27	SCREW TAPTITE M6-1X10 YELLOW CHROME
78	0D8564A	1	ASSEMBLY, MIXER/AIRBOX 990	113	0C9763	4	NUT, GROMMET 1/4 PLUG
	0D8564B	1	ASSEMBLY, MIXER/AIRBOX 760	114	0C3036	1	HOSE, BREATHER
79	0D2595	4	SCREW SHOULDER (8MM) M6-1.0 X 18	115	0C8919	1	BRACKET, STARTER
80	0D4417	4	WASHER,RUBBER 1/4" X 1/8" THICK	116	079246	1	SCREW HHC M6-1.0 x 16 WITH LOCK-WASHER
81	0C3025	1	SWITCH, OIL PRESS	117	0C3018	1	WRAPPER, UPPER CYLINDER 1
82	0D3083	1	ASSEMBLY, OIL DRAIN HOSE	118	0C3019	1	WRAPPER, LOWER CYLINDER 1
83	0C7292	1	NIPPLE, 3/4"-16 UNF	119	0D1142A	1	WRAPPER, LOWER CYLINDER 2
84	070185	1	FILTER, OIL D 69 X 64 LONG	120	0D1143	1	WRAPPER, UPPER CYLINDER 2
85	075281	1	SWITCH, THERMAL 284F	121	066849B	2	SCREW TAPTITE M5-0.8 X 8 BP
86	0C1085	2	SCREW PPHM M3-0.5 X 8	122	0C3053	1	ASSEMBLY, GROUND WIRE
87	043182	2	WASHER LOCK M3	123	0C3052	2	ASSEMBLY, IGNITION COIL
88	035461A	2	BARBED STR 1/4NPT X 3/8 WITH VIBRA SEAL	124	022097	4	WASHER LOCK M6-1/4
89	0C7649	4	CLAMP HOSE .38-.87	125	092079	4	SCREW TAPTITE M6-1.0 X 25 BP
90	0C9806	2	HOSE, 3/8" I.D. X 6" LONG	126	0E4271	1	STARTER
91	0C3026	1	COOLER, OIL	127	0D4529	2	SPARKPLUG
92	0C9764	4	PLASTITE,1/4-15 X 3/4	128	022129	2	WASHER LOCK M8-5/16
93	0C3043	2	GASKET, MANIFOLD / PORT	129	061906	2	SCREW HHC M8-1.25 X 85 G8.8
94	0C7694	1	MANIFOLD CYLINDER 2	130	082774	1	KEY, WOODRFF 4 X 19D
95	0C7693	1	MANIFOLD CYLINDER 1	131	052859	1	NUT HEX LOCK M10-1.50
96	0C3041	2	SLEEVE, RUBBER	132	0C8468	1	SPRING, ANTI-LASH
97	070008	4	WASHER FLAT M8 SS	133	0C3048	1	ROD, GOVERNOR CONTROL
98	070006	4	WASHER LOCK M8 SSTL	134	0D3754	1	ASSEMBLY, GOVERNOR LEVER
99	040976	4	SCREW SHC M8-1.25 X 20 G12.9	135	0D3742	1	SPRING, GOVERNOR
100	0C3016A	1	PLATE, BACKING GT990 WITH OIL COOL	136	0C8482	1	ASSEMBLY, GOVERNOR ADJUSTER
101	085011	1	INSULATOR ASSEMBLY IGNITION	137	0D2576	1	SCREW SHC M10-1.5 X 70 G10.9
102	0C3725B	1	FLYWHEEL ASSEMBLY	138	0D3743	1	SPRING, GOVERNOR IDLE
103	0C3031	1	FAN, NYLON	139	0D3705	1	ASSEMBLY, GOVERNOR ADJUSTER BRACKET
104	0C3032	1	PLATE, FAN	140	0C2993	1	SEAL, GOVERNOR SHAFT
105	0A5992	2	WASHER SHAKEPROOF INT M8 SS	141	0E1552	4	SCREW FHHC M6-1.0 X12 W/M5 HEX
106	051754	2	SCREW HHC M8-1.25 X 12 G8.8				
107	0C3033	1	WASHER, 25mm I.D.				
108	0C3034	1	NUT,HEX M24				

**Section 7 – Exploded Views and Parts Lists**

**Guardian Air-cooled 7 kW, 12 kW and 15 kW Generators  
7 kW Generator – Drawing No. 0D3504-C**

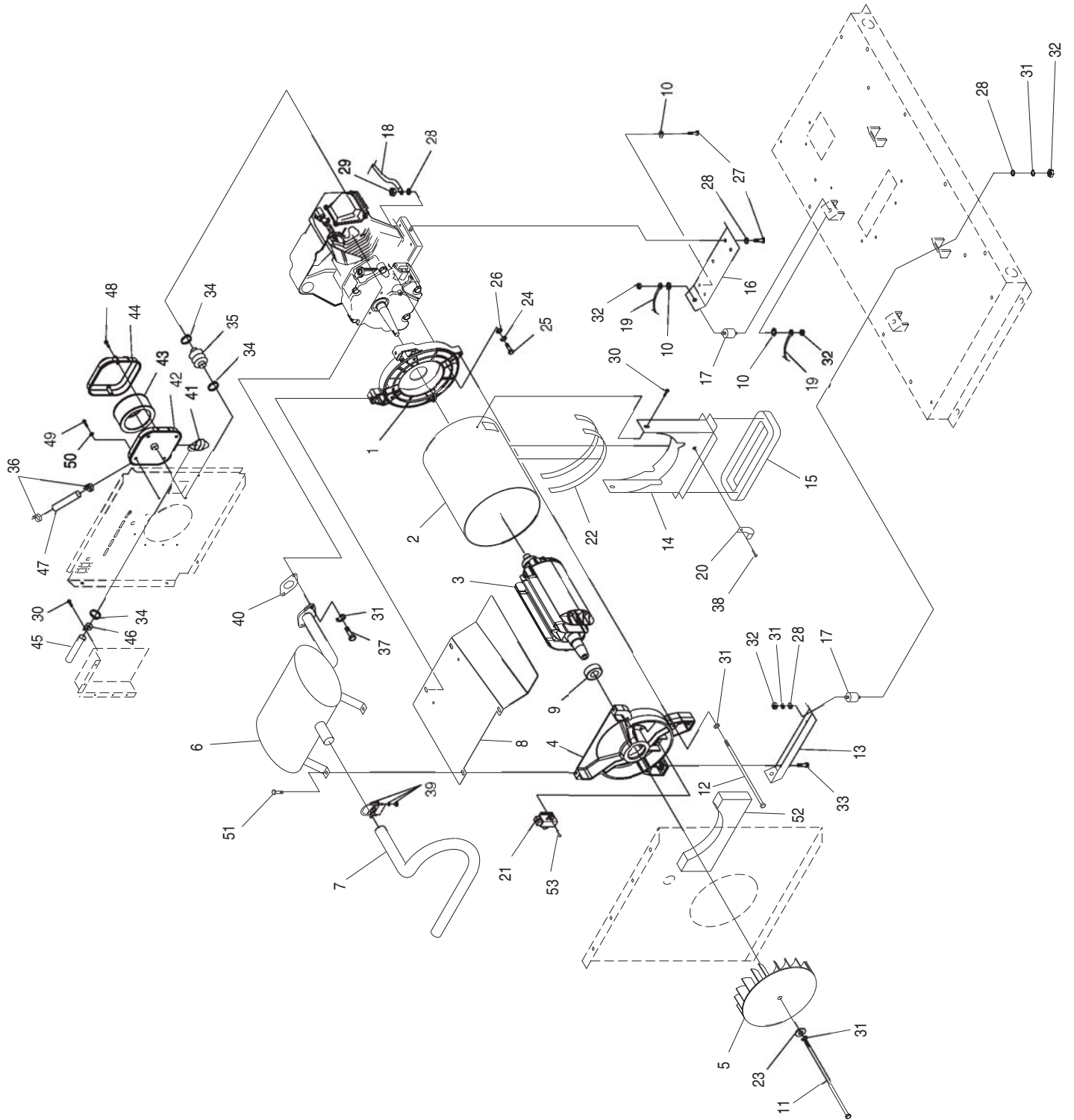

**Section 7 – Exploded Views and Parts Lists**  
**Guardian Air-cooled 7 kW, 12 kW and 15 kW Generators**  
**7 kW Generator – Drawing No. 0D3504-C**

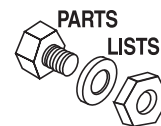

ITEM	PART NO.	QTY.	DESCRIPTION
1	0C6934	1	ADAPTOR, ENGINE
2	0C9935H	1	STATOR
3	0C9934H	1	ROTOR
4	0C6043A	1	CARRIER, REAR BEARING
5	0C8096	1	FAN, 8" CURVED BLADE
6	0C9593	1	MUFFLER
7	0D3220	1	TAIL PIPE, MUFFLER
8	0C8860	1	PANEL, MUFFLER BASE
9	031971	1	BEARING #6205-2RS-C3
10	0C3168	3	5/16 SPECIAL L/WASH
11	056147	1	BOLT ROTOR HHCS 5/16"-24 X 13-1/2" G5
12	0D1847	4	BOLT STATOR HHCS M8-1.25 x 305mm
13	0C7038C	1	BRACKET, ALTERNATOR MOUNTING
14	0D1647	1	DUCT, ALTERNATOR AIR
15	0D2558	1	GASKET, ALTERNATOR AIR DUCT
16	0C7038B	1	BRACKET, ENGINE MOUNTING
17	0C7758	4	RUBBER MOUNT
18	0388050AEO	1	CABLE, #6 40" BLACK BATTERY
19	0C2417A	1	EARTH STRAP 3/8X 3/8
20	082121C	1	CLIP-J VINYL COAT .625 ID
21	066386	1	ASSEMBLY BRUSH HOLDER
22	029451	1.8 FT	TAPE ELEC UL FOAM 1/8 X 1/2
23	049451	1	WASHER FLAT .406ID X 1.62OD
24	022237	4	WASHER LOCK 3/8
25	022511	4	BOLT HHC 3/8-16 X 1-1/4 G5
26	022131	4	WASHER FLAT 3/8 ZINC
27	039287	4	SCREW HHC M8-1.25 X 45 G8.8
28	022145	14	WASHER FLAT 5/16 ZINC
29	049820	4	NUT LOCK HEX M8-1.25 NYL INSRT
30	090388	3	SCREW TAP M6-1.0X12 BP
31	022129	13	WASHER LOCK M8-5/16
32	022259	8	NUT HEX 5/16-18 STEEL
33	059637	2	SCREW TAPTITE 3/8-16X 3/4" BP
34	048031K	3	BAND, HOSE CLAMP 35.05 DIA.
35	0C9592	1	BELLOWS
36	057822	2	CLAMP HOSE #8 .53 - 1.00
37	040976	2	SCREW SHC M8-1.25 X 20 G12.9
38	0C2824	1	SCREW TAPR #10-32 X 9/16
39	025145	1	U-BOLT 5/16"-18 X 1.25" W/ SADDLE
40	090239	1	GASKET, EXHAUST
41	0C6989	1	STINGER, ENGINE AIR IN
42	0D1214	1	BASE, AIR CLEANER
43	0C8127	1	ELEMENT, AIR CLEANER
44	0C3024	1	COVER, AIR CLEANER NG/LP
45	0D2273	1	TUBE, 1.25"O.D. x 20Ga. x 12.125" LONG
46	055934N	1	CLAMP VINYL 1.31 X .281 Z
47	074994	1.25 FT	HOSE 1/2ID PETROLEUM
48	0C5136A	2	KNOB, AIR CLEANER
49	074906	4	SCREW TAPTITE M6-1 X 20 BP
50	022473	4	WASHER FLAT 1/4 ZINC
51	0D4662	6	SCREW HHTT M8-1.2 X 20 BP
52	0C8290	1	GASKET, PANEL
53	066849	2	SCREW HHTT M5-0.8 X 16

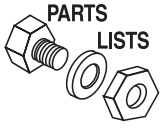

## Section 7 – Exploded Views and Parts Lists

Guardian Air-cooled 7 kW, 12 kW and 15 kW Generators  
 12 kW and 15 kW Generator – Drawing No. OD3417-E

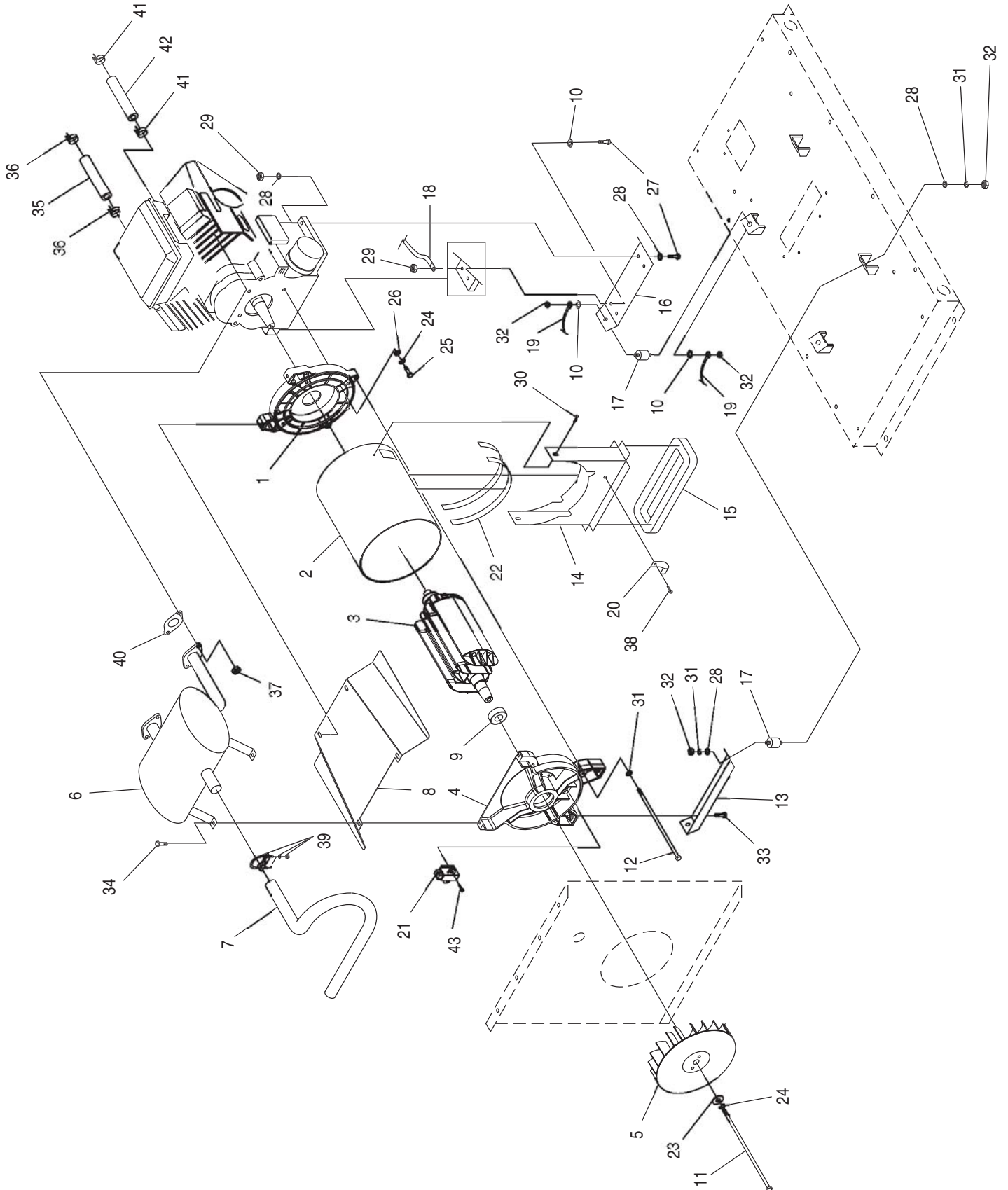

**Section 7 – Exploded Views and Parts Lists**  
**Guardian Air-cooled 7 kW, 12 kW and 15 kW Generators**  
**12 kW and 15 kW Generator – Drawing No. 0D3417-E**

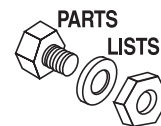

ITEM	PART NO.	QTY.	DESCRIPTION
1	0C6934	1	ADAPTOR, ENGINE
2	0C7930	1	STATOR 12KW
	0D2359		STATOR 13KW / 15KW
3	0C7944	1	ROTOR 12KW
	0D2356		ROTOR 13KW / 15KW
4	0C6043	1	CARRIER, REAR BEARING
5	0D2336	1	FAN, 12" CURVED BLADE
6	0D6634	1	MUFFLER
7	0D3220	1	TAIL PIPE, MUFFLER
8	0C8101	1	PANEL, MUFFLER BASE
9	056482	1	BEARING 1.1811-2.8346
10	0C3168	3	5/16 SPECIAL LOCK WASHER
11	0D1838	1	BOLT, HHCS 3/8"-24 x 15.50"
12	0D1846	4	BOLT, HHCS M8-1.25 x 345mm
13	0C7038	1	BRACKET, ALTERNATOR MOUNTING
14	0D1609	1	DUCT, ALTERNATOR AIR
15	0D2559	1	GASKET, ALTERNATOR AIR DUCT
16	0C7038A	1	BRACKET, ENGINE MOUNTING
17	0C7758	4	RUBBER MOUNT
18	0388050AD0	1	CABLE, #6 48" BLACK BATTERY
19	0C2417A	1	EARTH STRAP 3/8X 3/8
20	082121C	1	CLIP-J, VYNL COAT 0.625" ID
21	066386	1	ASSEMBLY BRUSH HOLDER
22	029451	2.6 FT	TAPE ELEC UL FOAM 1/8 X 1/2
23	049451	1	WASHER FLAT .406ID X 1.62OD
24	022237	5	WASHER LOCK 3/8
25	022511	4	SCREW HHC 3/8-16 X 1-1/4 G5
26	022131	4	WASHER FLAT 3/8 ZINC
27	039288	4	SCREW HHC M8-1.25 x 55 G8.8
28	022145	14	WASHER FLAT 5/16 ZINC
29	049820	4	NUT LOCK HEX M8-1.25 NYL INSERT
30	045756	2	SCREW TAPTITE M6-1.0X10 BP
31	022129	10	WASHER LOCK M8-5/16
32	022259	8	NUT HEX 5/16-18 STEEL
33	059637	2	SCREW TAPTITE 3/8-16 X 3/4 BP
34	083512	4	SCREW TAPTITE M8-1.25 X 16 BP
35	074994	2.83 FT	HOSE RES 1/2 LP GAS
36	057822	4	CLAMP HOSE #8 .53 - 1.00
37	052858	4	NUT LOCK M8
38	0C2824	1	SCREW TAP-R #10-32 x 9/16
39	025145	1	U-BOLT 5/16"-18 X 1.25" WITH SADDLE
40	0C4138	2	GASKET, EXHAUST PORT
41	048031C	2	CLAMP HOSE BAND 1/4"
42	030340	1.33 FT	HOSE 1/4 ID SAE 30R7
43	066849	2	SCREW HHTT M5-0.8 X 16

**Section 7 – Exploded Views and Parts Lists**

**Guardian Air-cooled 7 kW, 12 kW and 15 kW Generators  
GN410 Engine – Drawing No. 0D3539-F Part 1**

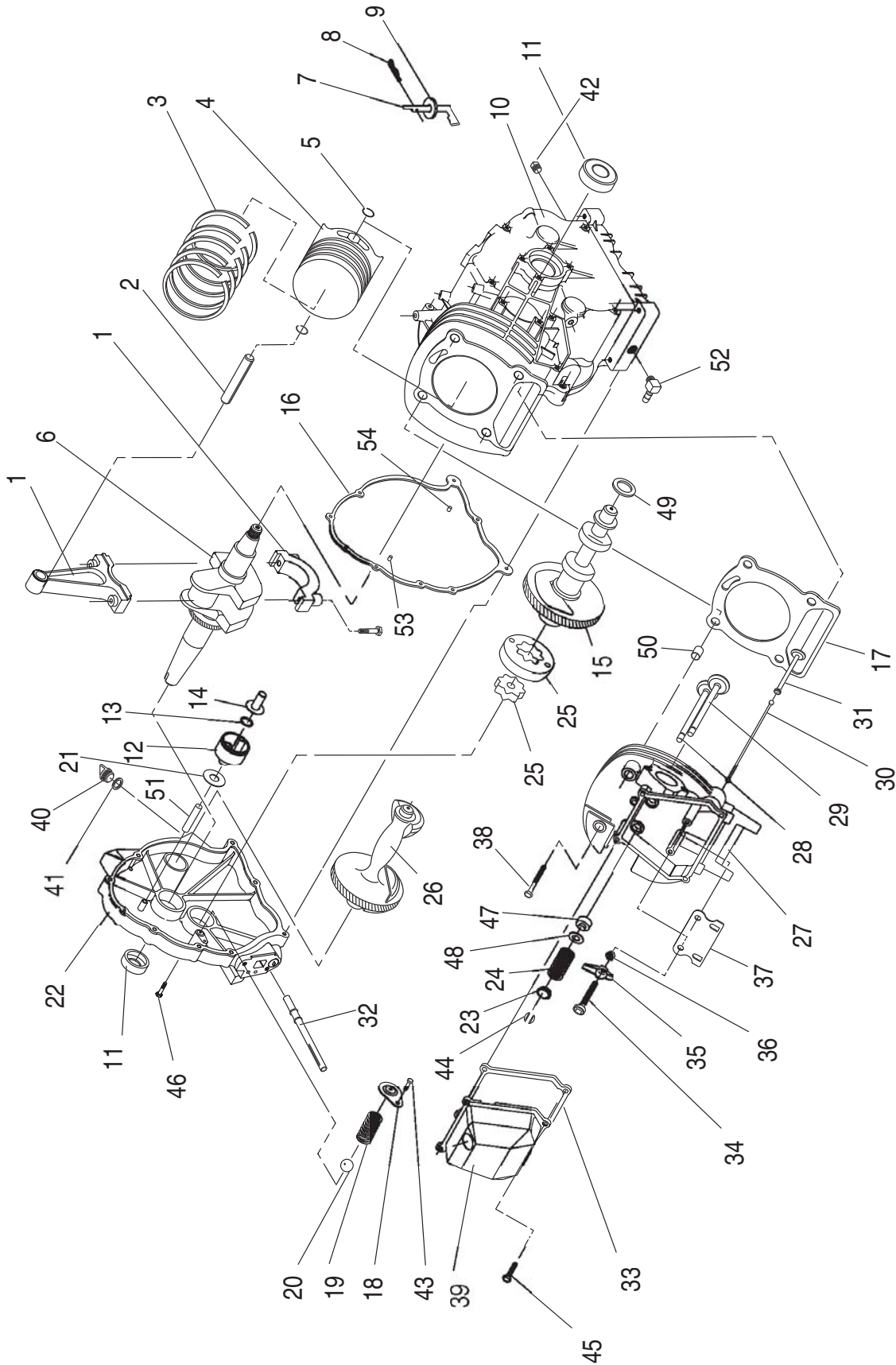

**Section 7 – Exploded Views and Parts Lists**  
**Guardian Air-cooled 7 kW, 12 kW and 15 kW Generators**  
**GN410 Engine – Drawing No. 0D3539-F Part 1**

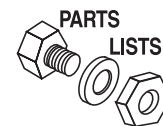

ITEM	PART NO.	QTY.	DESCRIPTION
1	071978	1	ASSEMBLY, CONNECTING ROD
2	071980	1	PIN, PISTON D20
3	021533	1	SET, PISTON RING 90MM
4	0C5848	1	PISTON, HC
5	071983	2	RETAINER, PISTON PIN 20
6	0D4287	1	ASSEMBLY, CRANKSHAFT GH410 SMALL TAPER
7	0A7628	1	ARM, GOVERNOR RC45
8	078658	1	PIN, "R" GOVERNOR ARM
9	078659	2	WASHER, GOVERNOR ARM THRUST
10	088261E	1	CRANKCASE, SUBASSEMBLY WITH PLUGS GH410
11	0E3812	2	SEAL, 35 I.D. CRANKSHAFT
12	0A7975	1	ASSEMBLY, GOVERNOR GEAR
13	078645	1	C-RING, GOVERNOR GEAR RETAINER
14	0A7811	1	SPOOL, GOVERNOR- MACHINE
15	0A9877	1	ASSEMBLY, CAMSHAFT & GEAR
16	076701	1	GASKET , CRANKCASE
17	021713B	1	GASKET, HEAD 410
18	078691	1	COVER, OIL PRESSURE RELIEF
19	0A5771	1	SPRING, OIL RELIEF 360
20	0A5776	1	BALL, DIA 11/32 PRESSURE RELIEF
21	076361	1	WASHER, THRUST GOVERNOR GEAR
22	0A8898D	1	ASSEMBLY, COVER, GEAR TOP CHECK / FILL
23	0D2274	2	RETAINER, VALVE SPRING
24	0C4391	2	VALVE SPRING LF
25	086025	1	SET,GEROTOR 12 THK
26	0C7393	1	BALANCER
27	021714	1	ASSEMBLY,CYLINDER HEAD SEATS & GUIDES
28	086516	1	VALVE, EXHAUST
29	086517	1	VALVE, INTAKE
30	0D9853B	2	PUSH ROD 174.9
31	083897	2	TAPPET
32	077158	1	ASSEMBLY, SCREEN OIL PICK-UP
33	0C3150	1	GASKET, ROCKER COVER 410
34	072694	2	STUD, D20 PIVOT BALL
35	083907	2	ROCKER ARM
36	072696	2	NUT, JAM (ROCKER ARM)
37	078694	1	PLATE, PUSH ROD GUIDE
38	021742	4	SCREW, HHFL M10-1.5 X 105
39	0D6094	1	ASSEMBLY, ROCKER COVER BREATHER
40	076329	1	PLUG, OIL FILL PLASTIC
41	0E0057	1	O-RING 17.8 I.D. x 2.4
42	0D4788	1	PLUG, STANDARD PIPE 3/8 STEEL SQUARE HEAD
43	074908	1	SCREW, TAPTITE M5-0.8 X 10 BP
44	086515	4	KEEPER, VALVE SPRING
45	078606	4	SCREW & LOCKWASHER M6-1 X 12
46	0A1442	8	SCREW, HHFC M8-1.25 X 42
47	078672	1	SEAL, VALVE STEM D7
48	089673	2	WASHER, VALVE SPRING
49	0B2104	1	WASHER, LARGE SPRING
50	078699C	2	DOWEL, SEAMED SLEEVE
51	0A7627	1	SHAFT, GOVERNOR RC55
52	043790A	1	BARBED ELBOW 90 3/8NPT X 3/8 LOCKTITE
53	088590	1	DOWEL DIA 12 X 18L
54	078699B	1	DOWEL, SLEEVE SEAMED 12 DIA.

**Section 7 – Exploded Views and Parts Lists**

**Guardian Air-cooled 7 kW, 12 kW and 15 kW Generators  
GN410 Engine – Drawing No. OD3539-F Part 2**

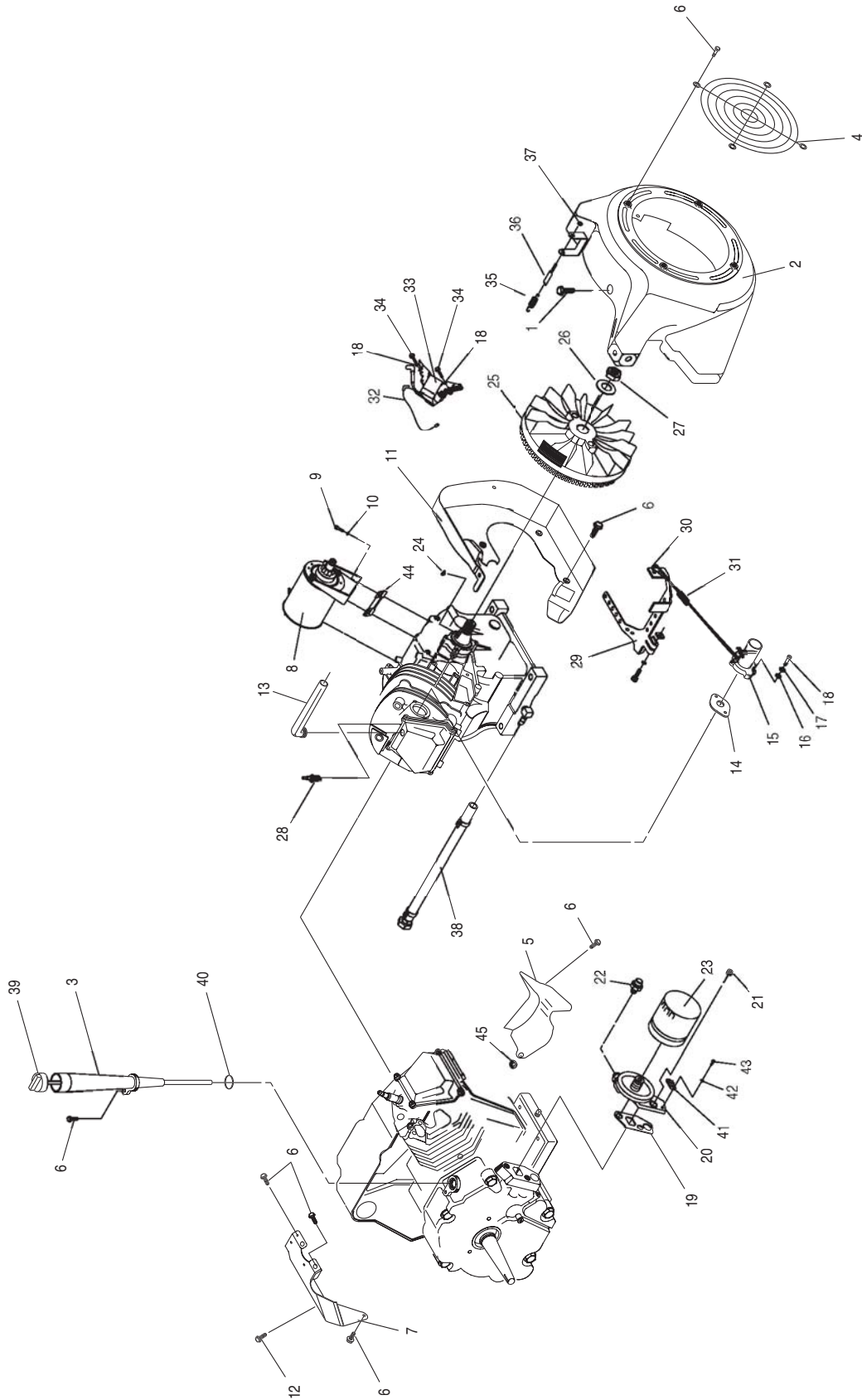



**Section 7 – Exploded Views and Parts Lists**  
**Guardian Air-cooled 7 kW, 12 kW and 15 kW Generators**  
**GN410 Engine – Drawing No. 0D3539-F Part 2**

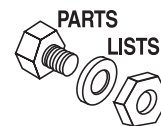

ITEM	PART NO.	QTY.	DESCRIPTION
1	0C1069	5	SCREW, TAPTITE M6-1.0X8 YELLOW CHROME
2	0D2922	1	HOUSING, BLOWER
3	0C8435	1	TUBE, DIPSTICK
4	0C9997	1	GUARD, FAN
5	088434	1	WRAPPER, BOTTOM
6	045756	11	SCREW, TAPTITE M6-1X10 YELLOW CHROME
7	088433B	1	WRAPPER, TOP
8	0D9004A	1	ASSY, STARTER
9	059985	2	SCREW, SHC M8-1.25 X 45 G12.9
10	022129	2	WASHER, LOCK M8-5/16
11	0C2458A	1	BACKPLATE, L/F D/F
12	083512	1	SCREW, TAPTITE M8-1.25 X 16 BP
13	0D1401A	1	BREATHER TUBE
14	091039	1	GASKET, INTAKE ADAPTER
15	0C9619	1	ASSEMBLY, PLASTIC CARB
16	049811	2	WASHER, FLAT M6
17	022097	4	WASHER, LOCK M6-1/4
18	040945	2	SCREW, SHC M6-1.0 X 20 G12.9
19	086999	1	GASKET,OIL FILTR ADAPTER
20	0D5667A	1	ADAPTER, OIL FILTER
21	049821	2	SCREW, SHC M8-1.25 X 30 G12.9
22	099236	1	SWITCH, OIL 8.0 PSI
23	070185	1	FILTER, OIL DIA. 69 X 64 LG
24	082774	1	KEY, WOODRFF 4 X 19D
25	091222E	1	FLYWHEEL WITH RING GEAR 32DEG.
26	067198N	1	WASHER,BELV-20 X 2.2
27	067890	1	NUT, HEX - FLYWHEEL
28	072347	1	SPARKPLUG
29	072734	1	ASSEMBLY,GOVERNOR LEVER 12 HP
30	072735	1	ROD,GOVERNOR CONTROL.
31	0C3978	1	SPRING, ANTI-LASH
32	0C6040	1	ASSEMBLY, WIRE
33	0D9760	1	ASSEMBLY, IGNITION COIL
34	092079	2	SCREW, TAPTITE M6-1.0 X 25 BP
35	0A8222	1	SPRING, GOVERNOR 8#
36	083502	1	BOLT, GOVERNOR ADJUST M5
37	082025	1	NUT HEX LOCK M5-0.8 NYINS ZINC
38	0D3083	1	ASSEMBLY, OIL DRAIN HOSE
39	0C8434	1	ASSEMBLY, CAP & DIPSTICK
40	090072	1	O-RING 9/16 X 3/4 X 3/32
41	075281	1	SWITCH, THERMAL
42	043182	2	WASHER LOCK M3
43	0C4739	2	SCREW PPHM M3-0.5 X 6
44	0C4373	1	SPACER, ENDFRAME
45	022717B	1	GROMMET

**Section 7 – Exploded Views and Parts Lists**

**Guardian Air-cooled 7 kW, 12 kW and 15 kW Generators  
Gas Regulator – Drawing No. 0D8720-B**

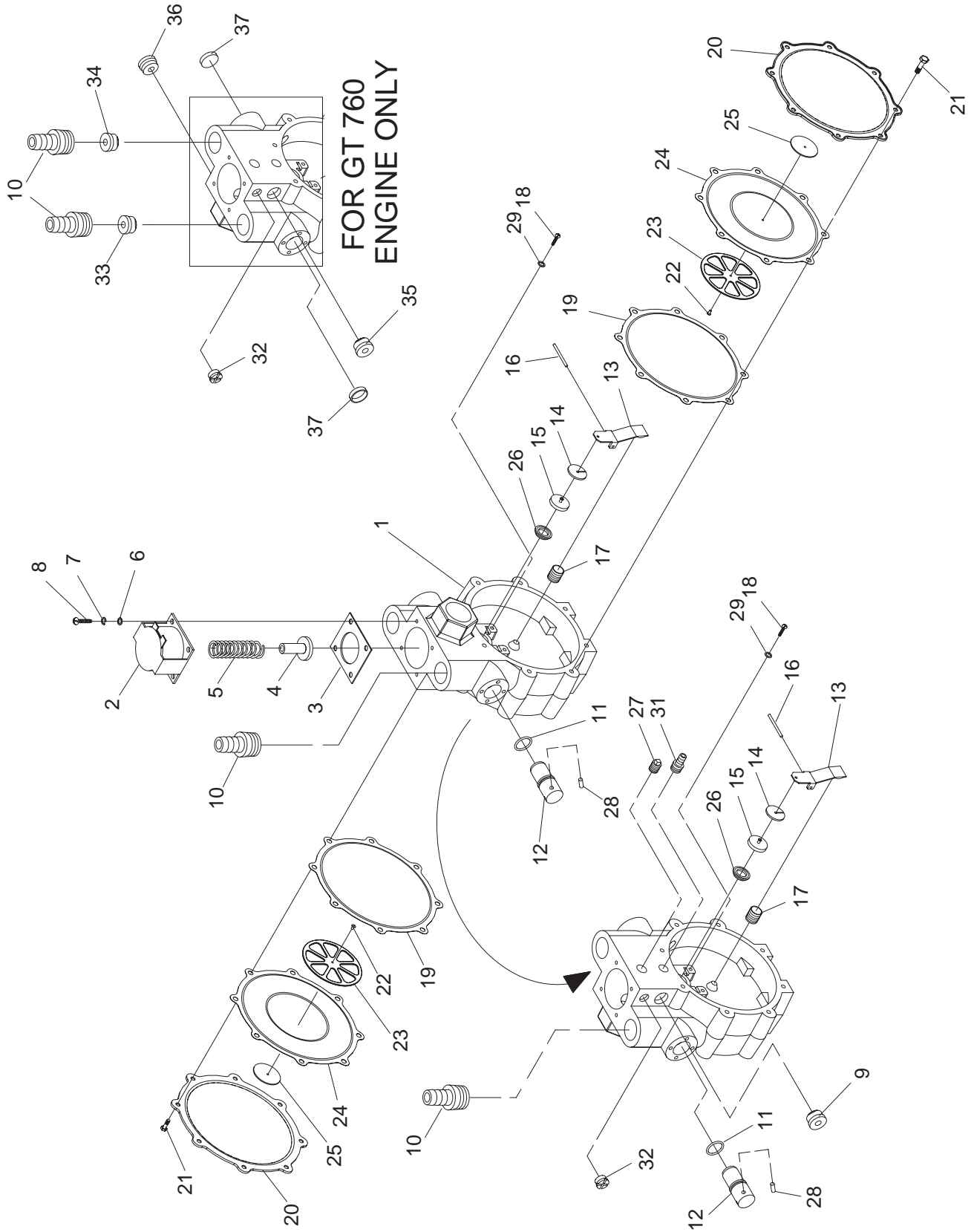

**Section 7 – Exploded Views and Parts Lists**  
**Guardian Air-cooled 7 kW, 12 kW and 15 kW Generators**  
**Gas Regulator – Drawing No. 0D8720-B**

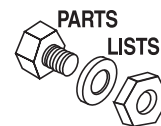

ITEM	PART NO.	QTY.	DESCRIPTION
1	0D5694	1	CASTING, TWIN REGULATOR HOUSING
2	0C5765	1	SOLENOID, TWIN REGULATOR
3	0C4647	1	GASKET , SOLENOID
4	0C4680	1	PLUNGER, LP REGULATOR ASSEMBLY
5	0C6070	1	SPRING-SOLENOID, PLUNGER
6	022985	4	WASHER, FLAT #6
7	022264	4	WASHER, LOCK M4
8	075475	4	SCREW PPHM M4-0.7 X 10
9	0C5760A	1	JET, GN 410 ENGINE LP (7KW)
10	0C6606	2*	BARBED STRAIGHT 1/2NPT x 1/2
11	097934	2*	O-RING, CHECK VALVE
12	0C4645	2*	ADJUSTER SCREW, TWIN REGULATOR
13	0C5761	2*	LEVER, REGULATOR
14	0C5968	2*	SUPPORT, INLET SEAL
15	0C6066	2*	SEAL, INLET
16	0C5759	2*	PIN, PIVOT ARM
17	0C5764	2	SPRING, REGULATOR
	0C5764A	1	SPRING, REGULATOR (7KW)
18	070728	4	SCREW, PFHMS M3-0.5 x 5
	070728	2	SCREW, PFHMS M3-0.5 x 5 (7KW)
19	0C6069	2*	GASKET, DIAPHRAGM
20	0C5762	2*	COVER, TWIN REGULATOR
21	045764	16	SCREW, TAPTITE M4X8 BP
	045764	8	SCREW, TAPTITE M4X8 BP (7KW)
22	0C6731	2*	RIVET, POP .118 X .125
23	0C6067	2*	SUPPORT, DIAPHRAGM
24	0C4706	2*	DIAPHRAGM, TWIN REGULATOR
25	0C6068	2*	CAP, DIAPHRAGM SUPPORT
26	0C4643A	2*	INLET, TWIN REGULATOR 11.11 DIA.
27	026073	1	PLUG, STANDARD PIPE 1/8 STEEL SQUARE HEAD
28	0A4032	2*	PIN, LIMITED ADJUSTMENT
29	0D3308	4	WASHER, FLAT M3 X 10mm O.D.
	0D3308	2	WASHER, FLAT M3 X 10mm O.D. (7KW)
30	0C4643	1	INLET, TWIN REGULATOR NO HOLE - NOT SHOWN (7KW)
31	028414A	1	BARBED STRAIGHT 1/8"NPT X 1/4"
32	0D5698A	1	JET IDLE PRIMER PHILLIPS HD
33	0C5760B	1	JET, GT760 CYL 1 NAT GAS
34	0C5760C	1	JET, GT760 CYL 2 NAT GAS
35	0C5760D	1	JET, GT 760 LP CYL 1
36	0C5760E	1	JET, GT760 LP CYL 2
37	0D3973	2	PLUG, EXPANSION 16mm

\* A QUANTITY OF 1 IS TO BE USED ON 7KW HOME STANDBY

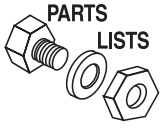

## Section 8 – Mounting Dimensions

### Guardian Air-cooled 7 kW, 12 kW and 15 kW Generators Drawing No. OD3739-B

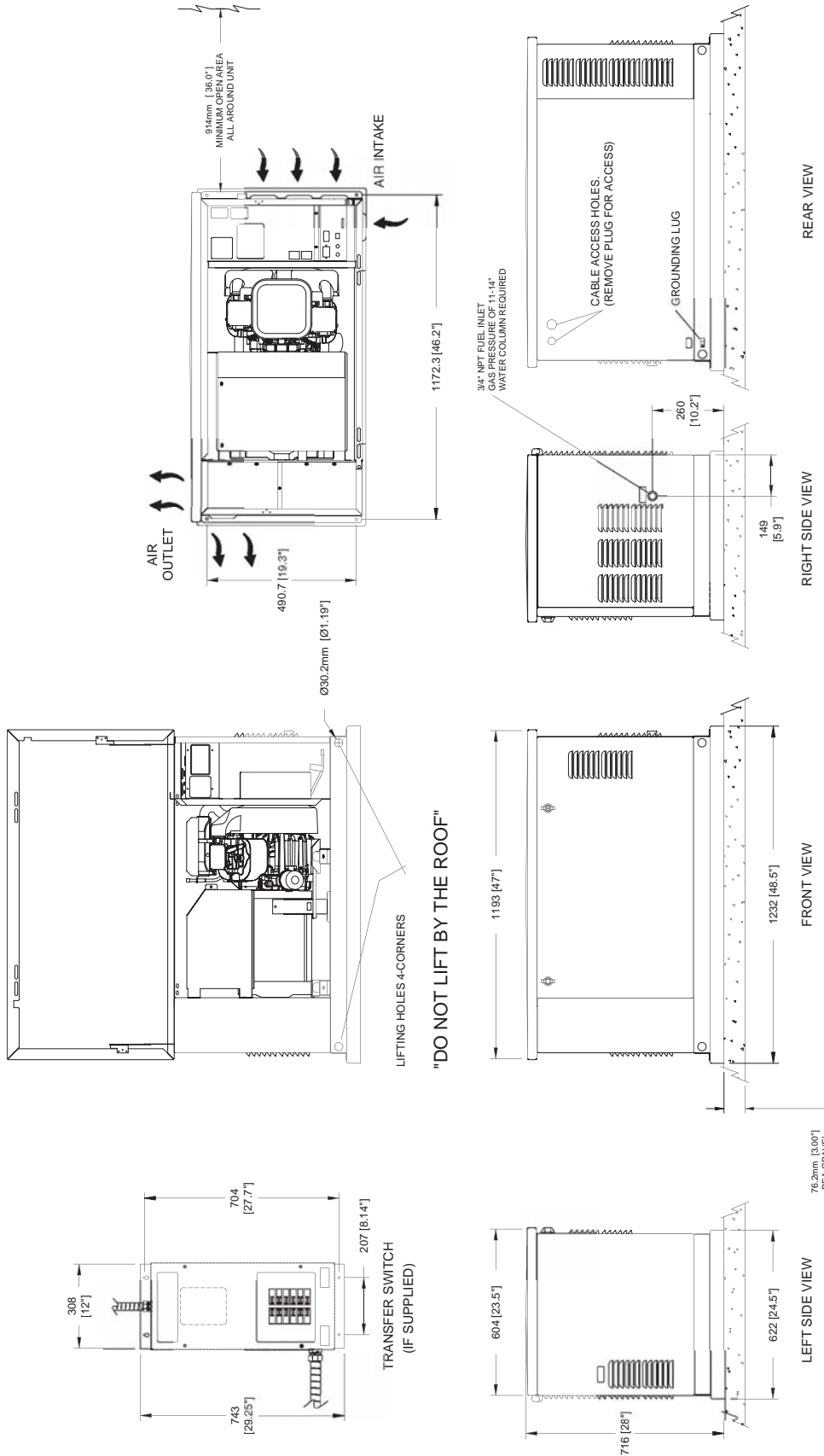

\*\*ALL DIMENSIONS IN:  
MILLIMETERS [INCHES]





## Section 10 – Warranty

### Guardian Air-cooled 7 kW, 12 kW and 15 kW Generators

**NOTE: This Emission Control Warranty Statement pertains to this product only IF the generator size is 15 kW or below.**

## CALIFORNIA AND FEDERAL EMISSION CONTROL WARRANTY STATEMENT

### YOUR WARRANTY RIGHTS AND OBLIGATIONS

The California Air Resources Board (CARB) and the United States Environmental Protection Agency (EPA), together with Generac Power Systems, Inc. (Generac), are pleased to explain the Emission Control System Warranty on your new engine.\* New (small off road) engines must be designed, built and equipped to meet stringent anti-smog standards for the state of California and the federal government. Generac will warrant the emission control system on your engine for the periods of time listed below provided there has been no abuse, neglect, unapproved modification or improper maintenance of your engine.

Your emission control system may include parts such as the carburetor, ignition and exhaust systems. Generac will repair your engine at no cost to you for diagnosis, replacement parts and labor, should a warrantable condition occur.

### MANUFACTURER'S EMISSION CONTROL SYSTEM WARRANTY COVERAGE:

Emissions control systems on engines are warranted for two years as hereinafter noted. If, during such warranty period, any emission-related component or system on your engine is found to be defective in materials or workmanship, repairs or replacement will be performed by a Generac Authorized Warranty Service Facility.

### PURCHASER'S/OWNER'S WARRANTY RESPONSIBILITIES:

As the engine purchaser/owner, you are responsible for the completion of all required maintenance as listed in your factory supplied *Owner's Manual*. For warranty purposes, Generac recommends that you retain all receipts covering maintenance on your engine. However, Generac cannot deny warranty solely because of the lack of receipts or for your failure to ensure the completion of all scheduled maintenance.

As the engine purchaser/owner, you should, however, be aware that Generac may deny any and/or all warranty coverage or responsibility if your engine, or a part/component thereof, has failed due to abuse, neglect, improper maintenance or unapproved modifications, or the use of counterfeit and/or "grey market" parts not made, supplied or approved by Generac.

**You are responsible for presenting your engine to a Generac Authorized Warranty Service Facility as soon as a problem occurs.** The warranty repairs should be completed in a reasonable amount of time, not to exceed 30 days.

Warranty service can be arranged by contacting either your selling dealer or a Generac Authorized Warranty Service Facility. To locate the Generac Authorized Warranty Service Facility nearest you, call our toll-free number:

**1-800-333-1322**

**IMPORTANT NOTE:** This warranty statement explains your rights and obligations under the Emission Control System Warranty (ECS Warranty), which is provided to you by Generac pursuant to California and federal law. See also the "Generac Limited Warranties for Generac Power Systems, Inc.," which is enclosed herewith on a separate sheet, also provided to you by Generac. The ECS Warranty applies **only** to the emission control system of your new engine. If there is any conflict in terms between the ECS Warranty and the Generac Warranty, the ECS Warranty shall apply except in circumstances where the Generac Warranty may provide a longer warranty period. Both the ECS Warranty and the Generac Warranty describe important rights and obligations with respect to your new engine.

Warranty service can be performed only by a Generac Authorized Warranty Service Facility. When requesting warranty service, evidence must be presented showing the date of the sale to the original purchaser/owner. The purchaser/owner shall be responsible for any expenses or other charges incurred for service calls and/or transportation of the product to/from the inspection or repair facilities. The purchaser/owner also shall be responsible for any and/or all damages or losses incurred while the engine is being transported/shipped for inspection or warranty repairs.

**If you have any questions regarding your warranty rights and responsibilities, you should contact Generac at the following address:**

ATTENTION WARRANTY DEPARTMENT  
GENERAC POWER SYSTEMS, INC.  
P.O. BOX 297  
WHITEWATER, WI 53190



### EMISSION CONTROL SYSTEM WARRANTY

Emission Control System Warranty (ECS Warranty) for 1997 and later model year engines:

- (a) Applicability: This warranty shall apply to 1997 and later model year engines. The ECS Warranty Period shall begin on the date the new engine or equipment is purchased by/delivered to its original, end-use purchaser/owner and shall continue for 24 consecutive months thereafter.
- (b) General Emissions Warranty Coverage: Generac warrants to the original, end-use purchaser/owner of the new engine or equipment, and to each subsequent purchaser/owner, that each of its engines is ...
- (1) Designed, built and equipped so as to conform with all applicable regulations adopted by the EPA and CARB pursuant to their respective authority, and
  - (2) Free from defects in materials and workmanship which, at any time during the ECS Warranty Period, may cause a warranted emissions-related part to fail to be identical in all material respects to the part as described in the engine manufacturer's application for certification.
- (c) The ECS Warranty only pertains to emissions-related parts on your engine, as follows:
- (1) Any warranted, emissions-related parts that are not scheduled for replacement as required maintenance in the *Owner's Manual* shall be warranted for the ECS Warranty Period. If any such part fails during the ECS Warranty Period, it shall be repaired or replaced by Generac according to Subsection (4) below. Any such part repaired or replaced under the ECS Warranty shall be warranted for the remainder of the ECS Warranty Period.
  - (2) Any warranted, emissions-related part that is scheduled only for regular inspection as specified in the *Owner's Manual* shall be warranted for the ECS Warranty Period. A statement in such written instructions to the effect of "repair or replace as necessary" shall not reduce the ECS Warranty Period. Any such part repaired or replaced under the ECS Warranty shall be warranted for the remainder of the ECS Warranty Period.
  - (3) Any warranted, emissions-related part that is scheduled for replacement as required maintenance in the *Owner's Manual* shall be warranted for the period of time prior to the first scheduled replacement point for that part. If the part fails prior to the first scheduled replacement, the part shall be repaired or replaced by Generac according to Subsection (4) below. Any such emissions-related part repaired or replaced under the ECS Warranty shall be warranted for the remainder of the ECS Warranty Period prior to the first scheduled replacement point for such emissions-related part.
  - (4) Repair or replacement of any warranted, emissions-related part under this ECS Warranty shall be performed at no charge to the owner at a Generac Authorized Warranty Service Facility.
  - (5) When the engine is inspected by a Generac Authorized Warranty Service Facility, the owner shall not be held responsible for diagnostic costs if the repair is deemed warrantable.
  - (6) Generac shall be liable for damages to other original engine components or approved modifications proximately caused by a failure under warranty of any emission-related part covered by the ECS Warranty.
  - (7) Throughout the ECS Warranty Period, Generac shall maintain a supply of warranted emission-related parts sufficient to meet the expected demand for such emission-related parts.
  - (8) Any Generac authorized and approved emission-related replacement part may be used in the performance of any ECS Warranty maintenance or repairs and will be provided without charge to the purchaser/owner. Such use shall not reduce Generac's ECS Warranty obligations.
  - (9) Unapproved, add-on, modified, counterfeit and/or "grey market" parts may not be used to modify or repair a Generac engine. Such use voids this ECS Warranty and shall be sufficient grounds for disallowing an ECS Warranty claim. Generac shall not be held liable hereunder for failures of any warranted parts of a Generac engine caused by the use of such an unapproved, add-on, modified, counterfeit and/or "grey market" part.

#### EMISSION RELATED PARTS INCLUDE THE FOLLOWING:

- |   |  |
|---|--|
| <ol style="list-style-type: none"> <li>1) Fuel Metering System:               <ol style="list-style-type: none"> <li>1.1) Gasoline carburetor assembly and its internal components (if so equipped).                   <ol style="list-style-type: none"> <li>a) Fuel filter (if so equipped)</li> <li>b) Carburetor gaskets</li> <li>c) Fuel pump (if so equipped)</li> </ol> </li> <li>1.2) LPG carburetion assembly and its internal components (if so equipped).                   <ol style="list-style-type: none"> <li>a) Fuel controller (if so equipped)</li> <li>b) Mixer and its gaskets (if so equipped)</li> <li>c) Carburetor and its gaskets (if so equipped)</li> <li>d) Primary gas regulator (if so equipped)</li> <li>e) LP liquid vaporizer (if so equipped)</li> </ol> </li> </ol> </li> </ol> | <ol style="list-style-type: none"> <li>2) Air Induction System including:               <ol style="list-style-type: none"> <li>a) Intake pipe/manifold</li> <li>b) Air cleaner</li> </ol> </li> <li>3) Ignition System including:               <ol style="list-style-type: none"> <li>a) Spark plug</li> <li>b) Ignition module</li> </ol> </li> <li>4) Catalytic Muffler Assembly (if so equipped) including:               <ol style="list-style-type: none"> <li>a) Muffler gasket</li> <li>b) Exhaust manifold</li> </ol> </li> <li>5) Crankcase Breather Assembly including:               <ol style="list-style-type: none"> <li>a) Breather connection tube</li> </ol> </li> </ol> |
|---|--|

\*Generac engine types covered by this warranty statement include the following:

- 1) Utility
- 2) Lawn and Garden Equipment
- 3) Recreational Vehicle (RV) Generator
- 4) Industrial Mobile (IM) Generator

**Part 2**



## Section 10 – Warranty

### Guardian Air-cooled 7 kW, 12 kW and 15 kW Generators

#### **GENERAC POWER SYSTEMS STANDARD "TWO YEAR" LIMITED WARRANTY FOR GUARDIAN "EMERGENCY AUTOMATIC STANDBY GENERATORS"**

For a period of two years from the date of original sale, Generac Power Systems, Inc. (Generac) will, at its option, repair or replace any part which, upon examination, inspection and testing by Generac or a Generac Authorized Warranty Service Dealer, is found to be defective under normal use and service, in accordance with the warranty schedule set forth below. Any equipment that the purchaser/owner claims to be defective must be returned to and examined by the nearest Generac Authorized Warranty Service Dealer. All transportation costs under the warranty, including return to the factory, are to be borne and pre-paid by the purchaser/owner. This warranty applies only to Generac emergency automatic standby generators sold and rated for use in "Standby" applications.

#### **WARRANTY SCHEDULE**

**YEARS ONE and TWO** - 100% (one hundred percent) transferable coverage on Labor and Part(s) listed (proof of purchase and maintenance is required):

- Engine - All Components
- Alternator - All Components
- Transfer System - All Components

All warranty expense allowances are subject to the conditions defined in Generac's Warranty Policies, Procedures and Flat Rate Manual.

#### **THIS WARRANTY SHALL NOT APPLY TO THE FOLLOWING:**

- Generac generators that utilize non-Generac replacement parts.
- Generac/Guardian generators utilizing non-Generac/Guardian automatic transfer switches.
- Any Generac generators used as rental or trailer mounted applications.
- Units used for prime power in place of existing utility power where utility power is present or in place of utility power where utility power service does not normally exist.
- Costs of normal maintenance, adjustments, installation and start-up.
- Failures caused by any contaminated fuels, oils, coolants or lack of proper fluid amounts.
- Failures due, but not limited, to normal wear and tear, accident, misuse, abuse, negligence or improper installation. As with all mechanical devices, the Generac engines need periodic part(s) service and replacement to perform well. This warranty will not cover repair when normal use has exhausted the life of a part(s) or engine.
- Failures caused by any external cause or act of God, such as collision, theft, vandalism, riot or wars, nuclear holocaust, fire, freezing, lightning, earthquake, windstorm, hail, volcanic eruption, water or flood, tornado or hurricane.
- Damage related to rodent infestation.
- Products that are modified or altered in a manner not authorized by Generac in writing.
- Any incidental, consequential or indirect damages caused by defects in materials or workmanship, or any delay in repair or replacement of the defective part(s).
- Failure due to misapplication.
- Telephone, cellular phone, facsimile, internet access or other communication expenses.
- Living or travel expenses of person(s) performing service, except as specifically included within the terms of a specific unit warranty period.
- Expenses related to "customer instruction" or troubleshooting where no manufacturing defect is found.
- Rental equipment used while warranty repairs are being performed.
- Overnight freight costs for replacement part(s).
- Overtime labor.
- Starting batteries, fuses, light bulbs and engine fluids.

#### **USE OF NON-GENERAC/GUARDIAN TRANSFER SWITCHES SHALL VOID THIS WARRANTY WITH RESPECT TO ALL GENERAC PRODUCT.**

THIS WARRANTY IS IN PLACE OF ALL OTHER WARRANTIES, EXPRESSED OR IMPLIED. SPECIFICALLY, GENERAC MAKES NO OTHER WARRANTIES AS TO THE MERCHANTABILITY OR FITNESS FOR A PARTICULAR PURPOSE. Some states do not allow limitations on how long an implied warranty lasts, so the above limitation may not apply to you.

GENERAC'S ONLY LIABILITY SHALL BE THE REPAIR OR REPLACEMENT OF PART(S) AS STATED ABOVE. IN NO EVENT SHALL GENERAC BE LIABLE FOR ANY INCIDENTAL OR CONSEQUENTIAL DAMAGES, EVEN IF SUCH DAMAGES ARE A DIRECT RESULT OF GENERAC'S NEGLIGENCE. Some states do not allow the exclusion or limitation of incidental or consequential damages, so the above limitation may not apply to you.

This warranty gives you specific legal rights. You also have other rights from state to state.

GENERAC® POWER SYSTEMS, INC.

P.O. BOX 297

WHITEWATER, WI 53190