



**Models: 004709-0,
005852-0**

Owner's Manual and Installation Instructions



**Air-cooled Recreational
Vehicle Generators
Quietpact 40G**

This manual should remain with the unit.

Table of Contents

Part – Owner’s Manual

Introduction	1
Read This Manual Thoroughly	1
Contents	1
Operation and Maintenance	1
How to Obtain Service	1
Authorized Service Dealer Locator Number	1
Safety Rules	2
General Information	4
1.1 Generator Identification	4
1.2 Generator Applicability	5
1.3 Safety	5
1.4 Generator AC Connection System	5
1.5 Specifications	5
Operation	7
2.1 Generator Control Panel	7
2.2 Optional Remote Start/Stop Panel.....	7
2.3 Automatic Choke.....	7
2.4 Before Starting the Engine.....	7
2.5 Starting the Generator	8
2.6 Stopping the Generator	8
2.7 Applying Loads to Generator	8
2.8 Do Not Overload the Generator.....	9
2.9 Protection Systems	9
2.10 Additional Information	10
Maintenance	10
3.1 Checking the Engine Oil Level.....	10
3.2 Changing the Engine Oil and/or Oil Filter	10
3.3 Maintaining the Engine Air Cleaner	11
3.4 Clean Air Intake.....	12
3.5 Checking the Engine Spark Plug.....	12
3.6 Fuel Filter	12
3.7 Clean Spark Arrestor	12
3.8 Cleaning the Generator.....	13
3.9 Battery Maintenance	13
3.10 Major Service Manual	14
3.11 Exercising the Generator	14
3.12 Out of Service Procedure	14
3.13 Adjusting Valve Clearance	14
3.14 RV Generator Service Interval.....	15
Notes	16

Part II – Installation Instructions

Safety Rules	18
Notice to Installer	18
General Information	20
1.1 Purpose and Scope of the Manual.....	20
1.2 Safety	20
1.3 Standards Booklets	20
1.4 Equipment Description	20
1.5 Generator Engine Operating Speed	20
1.6 Generator AC Connection System	20
Installation	22
2.1 Location and Support.....	22
2.2 Generator Compartments	23
2.3 Cooling and Ventilating Air.....	26
2.4 Gasoline Fuel System.....	26
2.5 Exhaust System.....	27
2.6 Electrical Connections.....	28
2.7 Battery Installation.....	29
2.8 Optional Accessories	31
Post-installation Start-up Adjustments	32
3.1 Post Installation Tests.....	32
3.2 Before Initial Start-up	32
3.3 Initial Start	32
3.4 Testing Under Load	32
3.5 Installation Checklist	33
Troubleshooting	34
Troubleshooting Guide.....	34
Notes	35
Electrical Data	38
Warranty	40

INTRODUCTION

Thank you for purchasing this model by Generac Power Systems Inc. This model is designed and manufactured to supply electrical power for recreational vehicles.

Every effort was expended to make sure that the information and instructions in this manual were both accurate and current at the time the manual was written. However, the manufacturer reserves the right to change, alter or otherwise improve this product(s) at any time without prior notice.

READ THIS MANUAL THOROUGHLY

If any portion of this manual is not understood, contact the nearest Authorized Service Dealer for starting, operating and servicing procedures.

Throughout this publication, and on tags and decals affixed to the generator, DANGER, WARNING, CAUTION and NOTE blocks are used to alert personnel to special instructions about a particular operation that may be hazardous if performed incorrectly or carelessly. Observe them carefully. Their definitions are as follows:

▲ DANGER!

Indicates a hazardous situation or action which, if not avoided, will result in death or serious injury.

▲ WARNING!

Indicates a hazardous situation or action which, if not avoided, could result in death or serious injury.

▲ CAUTION!

Indicates a hazardous situation or action which, if not avoided, could result in minor or moderate injury.

NOTE:

Notes contain additional information important to a procedure and will be found within the regular text body of this manual.

These safety warnings cannot eliminate the hazards that they indicate. Common sense and strict compliance with the special instructions while performing the action or service are essential to preventing accidents.

Four commonly used safety symbols accompany the **DANGER**, **WARNING** and **CAUTION** blocks. The type of information each indicates is as follows:

 **This symbol points out important safety information that, if not followed, could endanger personal safety and/or property of others.**

 **This symbol points out potential explosion hazard.**

 **This symbol points out potential fire hazard.**

 **This symbol points out potential electrical shock hazard.**

The operator (driver) is responsible for proper and safe use of the vehicle and its equipment, and the safety of all vehicle occupants. We strongly recommend that the operator read this manual and thoroughly understand all instructions before using this equipment. We also strongly recommend instructing other occupants in the vehicle how to properly start and operate the generator. This prepares them if they need to operate the equipment in an emergency.

CONTENTS

This manual contains pertinent owner's information, including warranty, electrical diagrams, exploded views and lists of repair parts. In addition, the latter portion of this manual contains information necessary for the proper installation of these generators.

OPERATION AND MAINTENANCE

It is the operator's responsibility to perform all safety checks, to make sure that all maintenance for safe operation is performed promptly, and to have the equipment checked periodically by an Authorized Service Dealer. Normal maintenance service and replacement of parts are the responsibility of the owner/operator and, as such, are not considered defects in materials or workmanship within the terms of the warranty. Individual operating habits and usage contribute to the need for maintenance service.

Proper maintenance and care of the generator ensures a minimum number of problems and keep operating expenses at a minimum. See an Authorized Service Dealer for service aids and accessories.

HOW TO OBTAIN SERVICE

When the generator requires servicing or repairs, simply contact an Authorized Service Dealer for assistance. Service technicians are factory-trained and are capable of handling all service needs.

When contacting an Authorized Service Dealer or the factory about parts and service, always supply the complete model number and serial number of the unit as given on its data label, which is located on the generator.

Model No. _____ Serial No. _____

AUTHORIZED SERVICE DEALER LOCATION

To locate the nearest AUTHORIZED SERVICE
DEALER, please call this number:

1-800-333-1322

or locate us on the web at:

www.guardiangenerators.com

Safety Rules

! SAVE THESE INSTRUCTIONS – The manufacturer suggests that these rules for safe operation be copied and posted in potential hazard areas of the recreational vehicle. Safety should be stressed to all operators and potential operators of this equipment.

Study these SAFETY RULES carefully before installing, operating or servicing this equipment. Become familiar with this manual and with the unit. The generator can operate safely, efficiently and reliably only if it is properly installed, operated and maintained. Many accidents are caused by failing to follow simple and fundamental rules or precautions.

The manufacturer cannot anticipate every possible circumstance that might involve a hazard. The warnings in this manual, and on tags and decals affixed to the unit, are, therefore, not all-inclusive. If using a procedure, work method or operating technique the manufacturer does not specifically recommend, ensure that it is safe for others. Also make sure the procedure, work method or operating technique utilized does not render the generator unsafe.

! DANGER!

! Despite the safe design of this generator, operating this equipment imprudently, neglecting its maintenance or being careless can cause possible injury or death. Permit only responsible and capable persons to operate or maintain this equipment.

! Potentially lethal voltages are generated by these machines. Ensure all steps are taken to render the machine safe before attempting to work on the generator.

! Parts of the generator are rotating and/or hot during operation. Exercise care near running generators.

GENERAL HAZARDS

- For safety reasons, the manufacturer recommends that the installation, initial start-up and maintenance of this equipment is carried out by an Authorized Service Dealer.
- The generator engine releases DEADLY carbon monoxide gas through its exhaust system. This dangerous gas, if breathed in sufficient concentrations, can cause unconsciousness or even death. Never operate the generator set with the vehicle inside any garage or other enclosed area. **DO NOT OPERATE THE GENERATOR IF THE EXHAUST SYSTEM IS LEAKING OR HAS BEEN DAMAGED. SYMPTOMS OF CARBON MONOXIDE POISONING ARE (a) inability to think coherently, (b) nausea, (c) vomiting, (d) twitching muscles, (e) throbbing temples, (f) dizziness, (g) headaches, (h) weakness, and (i) sleepiness. IF EXPERIENCING ANY OF THESE SYMPTOMS, MOVE INTO FRESH AIR IMMEDIATELY. IF SYMPTOMS PERSIST, GET MEDICAL HELP.** Shut down the generator and do not operate it until it has been inspected and repaired.
- Never sleep in the vehicle while the genset is running unless the vehicle has a working carbon monoxide detector. The exhaust system must be installed in accordance with the genset installation manual. Make sure there is ample fresh air when operating the genset in a confined area.
- The engine exhaust fumes contain carbon monoxide, which can be DEADLY. This dangerous gas, if breathed in sufficient concentrations, can cause unconsciousness or even death. This exhaust system must be installed properly, in strict compliance with applicable codes and standards. Following installation, do nothing that might render the system unsafe or in noncompliance with such codes and standards. The generator compartment must be completely vapor sealed from the vehicle interior. There must be no possibility of exhaust fumes entering the vehicle interior. Never operate this equipment with a leaking or defective exhaust system.
- Keep hands, feet, clothing, etc., away from drive belts, fans, and other moving or hot parts. Never remove any drive belt or fan guard while the unit is operating.
- Adequate, unobstructed flow of cooling and ventilating air is critical to correct generator operation and is required to expel toxic fumes and fuel vapors from the generator compartment. Without sufficient cooling airflow, the engine/generator quickly overheats, which causes serious damage to the generator. Do not alter the installation or permit even partial blockage of ventilation provisions, as this can seriously affect safe operation of the generator.
- When working on this equipment, remain alert at all times. Never work on the equipment when physically or mentally fatigued.
- Inspect the generator regularly, and contact the nearest Authorized Service Dealer immediately for parts needing repair or replacement.
- Before performing any maintenance on the generator, disconnect its battery cables to prevent accidental start up. Disconnect the cable from the battery post indicated by a NEGATIVE, NEG or (–) first. Reconnect that cable last.
- Never use the generator or any of its parts as a step. Stepping on the unit can stress and break parts, and may result in dangerous operating conditions from leaking exhaust gases, fuel leakage, oil leakage, etc.

ELECTRICAL HAZARDS

- The generator covered by this manual produces dangerous electrical voltages and can cause fatal electrical shock. Avoid contact with bare wires, terminals, connections, etc., while the unit is running. Ensure all appropriate covers, guards and barriers are in place before operating the generator. If work must be done around an operating unit, stand on an insulated, dry surface to reduce shock hazard.
- Do not handle any kind of electrical device while standing in water, while barefoot, or while hands or feet are wet. DANGEROUS ELECTRICAL SHOCK MAY RESULT.
- During installation onto the vehicle, have the generator properly grounded (bonded) either by solid mounting to the vehicle frame or chassis, or by means of an approved bonding conductor. DO NOT disconnect the bonding conductor, if so equipped. DO NOT reconnect the bonding conductor to any generator part that might be removed or disassembled during routine maintenance. If the grounding conductor must be replaced, use only a flexible conductor that is of No. 8 American Wire Gauge (AWG) copper wire minimum.
- In case of accident caused by electric shock, immediately shut down the source of electrical power. If this is not possible, attempt to free the victim from the live conductor. AVOID DIRECT CONTACT WITH THE VICTIM. Use a nonconducting implement, such as a rope or board, to free the victim from the live conductor. If the victim is unconscious, apply first aid and get immediate medical help.
- Never wear jewelry when working on this equipment. Jewelry can conduct electricity resulting in electric shock, or may get caught in moving components causing injury.

FIRE HAZARDS

- For fire safety, the generator must be installed and maintained properly. Installation always must comply with applicable codes, standards, laws and regulations. Adhere strictly to local, state and national electrical and building codes. Comply with regulations the Occupational Safety and Health Administration (OSHA) has established. Also, ensure that the generator is installed in accordance with the manufacturer's instructions and recommendations. Following proper installation, do nothing that might alter a safe installation and render the unit in noncompliance with the aforementioned codes, standards, laws and regulations.
- Keep a fire extinguisher in the vehicle at all times. Extinguishers rated "ABC" by the National Fire Protection Association are appropriate for use on the recreational vehicle generator electrical system. Keep the extinguisher properly charged and be familiar with its use. If there are any questions pertaining to fire extinguishers, consult the local fire department.

EXPLOSION HAZARDS

- Do not smoke around the generator. Wipe up any fuel or oil spills immediately. Ensure that no combustible materials are left in the generator compartment, or on or near the generator, as FIRE or EXPLOSION may result. Keep the area surrounding the generator clean and free from debris.
- Gasoline is extremely FLAMMABLE and its vapors are EXPLOSIVE. Do not permit smoking, open flame, sparks or any source of heat in the vicinity while handling gasoline. Comply with all laws governing the storage and handling of gasoline.

CALIFORNIA PROPOSITION 65 WARNING

Engine exhaust and some of its constituents are known to the State of California to cause cancer, birth defects and other reproductive harm.

CALIFORNIA PROPOSITION 65 WARNING

This product contains or emits chemicals known to the State of California to cause cancer, birth defects and other reproductive harm.

General Information

1.1 GENERATOR IDENTIFICATION

Please record the following information from the generator DATA DECAL or information decal.

- | | |
|-----------------------|------------------------|
| 1. Model Number _____ | 2. Serial Number _____ |
| 3. kW Rating _____ | 4. Rated Voltage _____ |

- | | |
|---|--|
| 1. Generator Air Intake | 10. Fuel Pump (Behind Access Panel) |
| 2. Engine Start/Stop Switch | 11. Fuel Filter (Side View) |
| 3. Fuse | 12. Oil Filter |
| 4. Optional Remote Panel Receptacle (Side View) | 13. Oil Drain Cap |
| 5. Generator AC Output Leads (Side View) | 14. Oil Dipstick |
| 6. Fuel Primer Switch | 15. Air Filter (Behind Access Panel) |
| 7. Circuit Breaker | 16. Oil Fill |
| 8. Starter Contactor | 17. Spark Plug |
| 9. Fuel Inlet | 18. Evaporative Port (model 004709-0 only) |

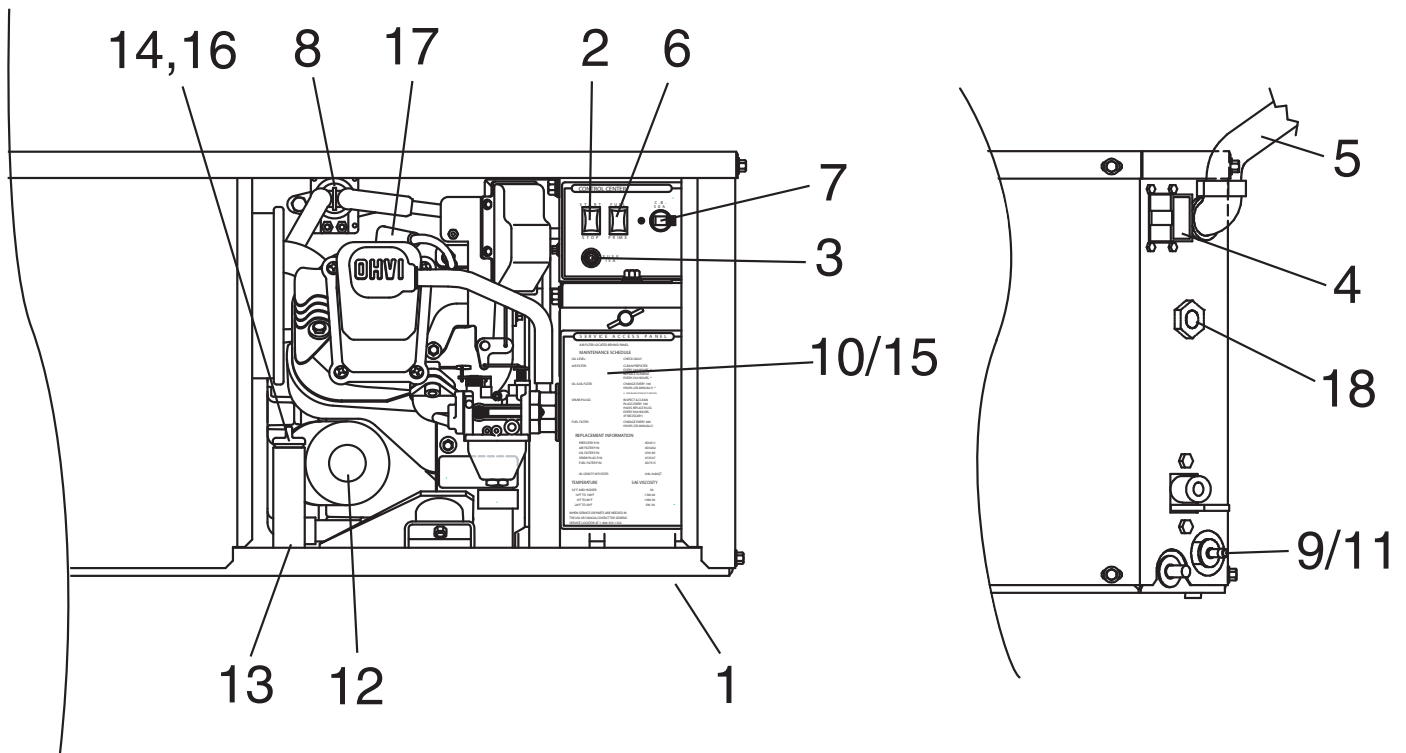

1.2 GENERATOR APPLICABILITY

These generators have been designed and manufactured for supplying electrical power for recreational vehicles. Do not modify the generator or use it for any application other than for what it was designed. If there are any questions pertaining to its application, contact an Authorized Service Dealer. Do not use the unit until advised by a competent authority.

⚠ DANGER!

⚠ For fire safety, the generator must have been properly installed in compliance with ANSI 119.2-1975/NFPA 501C-1974, "Standard for Recreational Vehicles, Part III – Installation of Electrical Systems." The generator also must have been installed in strict compliance with the manufacturer's detailed installation instructions. After installation, do nothing that might render the unit in noncompliance with such codes, standards and instructions.

Use this generator to supply electrical power for operating 120-volt, single-phase, 60 Hertz, AC electrical loads. These loads can require up to 3,600 watts (3.6 kW) of power, but cannot exceed 30 AC amperes of current at 120 volts.

⚠ CAUTION!

⚠ Do not overload the generator. Some installations may require that electrical loads be alternated to avoid overloading. Applying excessively high electrical loads may damage the generator and may shorten its life. Add up the rated watts of all electrical lighting, appliance, tool and motor loads the generator will power at one time. This total should not be greater than the wattage capacity of the generator. If an electrical device nameplate gives only volts and amps, multiply volts times amps to obtain watts (volts x amps = watts). Some electric motors require more watts of power (or amps of current) for starting than for continuous operation.

1.3 SAFETY

Before attempting to use the generator set, carefully read the "Safety Rules" section of this manual. Comply strictly with these rules to prevent accidents and damage to equipment and/or property. We suggest copying and posting the "Safety Rules" in potential hazard areas of the vehicle. Stress safety to all operators and potential operators of this equipment.

1.4 GENERATOR AC CONNECTION SYSTEM

This generator set is equipped with dual stator AC power windings. These two-stator windings supply electrical power to customer electrical loads by means of a two-wire connection system. Note, however, that the neutral is bonded to the frame of the engine-generator.

The generator may have been installed so that it powers 120-volt AC loads (Figure 1.1). It can be wired to connect 120-volt AC electrical loads. This procedure should be done by an Authorized Service Dealer or other qualified installer.

Figure 1.1 – Connections for 120 Volts Only

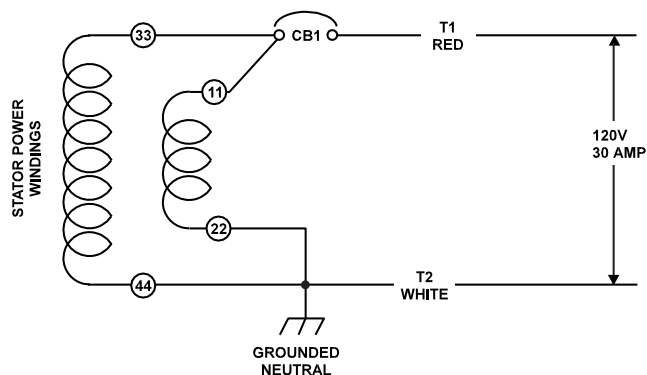

1.5 SPECIFICATIONS

1.5.1 FUEL REQUIREMENTS

This generator is equipped with a gasoline fuel system. Depending on the installation, the generator may have either a separate fuel tank, or it may "share" the vehicle engine's fuel tank.

NOTE:

Some installations using a "shared" fuel tank may have a generator fuel pickup tube that is shorter than the vehicle engine's pickup tube. Such an arrangement causes the generator engine to "run out of gas" while adequate fuel for the vehicle remains in the tank.

To reduce lead and carbon deposits use high quality UNLEADED gasoline with the generator. Leaded REGULAR grade gasoline is an acceptable substitute.

NOTE:

Using unleaded gasoline contributes to longer engine valve life by reducing lead and carbon deposits.

General Information

⚠ CAUTION!

! The manufacturer does not recommend using any gasoline containing alcohol (such as "gasohol"). If using any gasoline containing alcohol, it must not contain more than 10 percent ethanol, and it must be removed from the generator during storage. Do NOT use any gasoline containing methanol. If using gasoline with alcohol, inspect more frequently for fuel leaks and other abnormalities.

1.5.2 FUEL CONSUMPTION

Model	No Load	1/2 Load	Full Load
004709-0	0.24	0.35	0.55
Fuel consumption is in gal/hr.			

1.5.3 ENGINE OIL REQUIREMENTS

Use only high quality detergent oil rated with American Petroleum Institute (API) Service Classification SF, SG or SH. The recommended oil weights include the following:

- During summer months: SAE 30. An acceptable substitute is SAE 10W-30.
- During winter months: SAE 5W-30. DO NOT USE SAE 10-W40.

Crankcase and oil filter capacity is approximately 800 mL or .84 U.S. quarts. Do NOT use special additives. See sections "Checking the Engine Oil Level" and "Changing the Engine Oil and/or Oil Filter" for oil level check and fill procedures.

1.5.4 ENGINE

Type of Engine	GN-220, Single-cylinder
Cooling Method	Air-cooled
Rated Horsepower	7.8 @ 4,200 rpm
Displacement	220cc
Cylinder Block	Aluminum w/Cast Iron Sleeve
Type of Governor	Mechanical, Fixed Speed
Air Cleaner	Paper Element w/Foam Precleaner
Starter	12-volt DC Electric
Ignition System	Solid-state w/Flywheel Magneto
Recommended Spark Plug	
Champion	RC14YC
AC	R45S
Fram Autolite	65
Spark Plug Gap	0.030 inch (76 mm)
Recommended Minimum Battery	400 Cold-cranking Amperes

1.5.5 GENERATOR

Rated Maximum Continuous	
AC Output (Gasoline)	3,600 Watts (3.6 kW)
Rated Voltage	120 Volts AC
Rated Maximum Continuous	
AC Current (Gasoline)	30 Amperes
Phase	Single
Rotor RPM	3,600
Number of Rotor Poles	2
Engine RPM	3,600
Rated AC Frequency	60 Hz
Battery Charge Voltage	14 Volts DC
Battery Charge Current	2 Amperes (max)
Gasoline weight	170 Pounds
Length	749.8 mm (29.52 in.)
Width	483.1 mm (19.02 in.)
Height	342.2 mm (13.47 in.)

* Maximum wattage and current are subject to, and limited by, such factors as fuel Btu content, ambient temperature, altitude, engine condition, etc.. Maximum power decreases about 3.5% for each 1,000 feet above sea level; and will also decrease about 1% for each 6° C (10° F) above 16° C (60° F) ambient temperature.

1.5.6 EMISSIONS COMPLIANCE PERIOD

For non-handheld engines the Emissions Compliance Period referred to on the Emissions Compliance Label indicates the number of operating hours for which the engine has been shown to meet Federal emission requirements.

- For engines less than 225 cc displacement, Category C=125 hours, B=250 hours, and A=500 hours.
- For engines of 225 cc or more, Category C=250 hours, B=500 hours, and A=1000 hours.

1.5.7 EVAPORATIVE EMISSIONS INFORMATION

This generator is subject to evaporative emission standards which have been implemented by the California Air Resource Board (CARB) and the Environmental Protection Agency (EPA). If this generator is offered for sale in the state of California, it must be covered by a CARB evaporative Executive Order. If this generator is offered for sale to the final consumer in any other state, certified low-permeation fuel line must be used to supply fuel to the generator as required by EPA.

Anyone who installs or configures a fuel system to supply this generator with gasoline is required to comply with all applicable evaporative emission regulations. If this generator is configured such that it shares the primary fuel system of a vehicle in which it is installed, reduced certification requirements may apply. See the CARB guidance document MAC 05-05, located at <http://www.arb.ca.gov/msprog/mac/mac0505/mac0505.pdf> for further details. If this generator is installed such that it uses a dedicated fuel system, detailed evaporative emission requirements apply; contact a reputable fuel system manufacturer to purchase a complete fuel system certified for use with this generator, or consult the California Code of Regulations if you wish to obtain certification on your own. See the installation instructions in this manual for connecting fuel system vapor lines to the engine.

This generator is not legal for sale in the state of California unless all CARB evaporative emission requirements are adhered to, and is not legal for sale in any other state unless certified low-permeation fuel line is used to supply the generator with gasoline. Contact the California Air Resource Board or the Environmental protection agency for further information. CARB regulations can be found in 13 CCR §§2750 – 2773; EPA regulations can be found in 40 CFR Part 90.

2.1 GENERATOR CONTROL PANEL

The following features are mounted on the generator control panel (Figure 2.1):

Figure 2.1 – Generator Control Panel

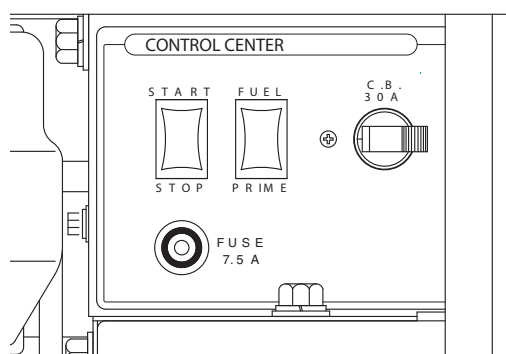

2.1.1 FUEL PRIMER

Before starting a cold engine (if it has not been started in more than two weeks), press this switch for approximately 10 to 15 seconds to bring fuel from the tank to the carburetor. This rocker type switch springs back into its original position when released.

2.1.2 START/STOP SWITCH

To crank and start the engine, hold this switch in the START position. Release the switch when the engine starts. To stop an operating engine, press and hold the switch in the STOP position until the engine shuts off. The switch center position is the RUN position.

2.1.3 FUSE

The fuse protects the engine's DC control circuit against electrical overload. If the fuse element has melted open due to overloading, the engine cannot be cranked. If the fuse must be replaced, use only an identical replacement.

2.1.4 MAIN BREAKER

The main breaker protects the generator's AC output circuit against overload and provides a method of turning OFF the generator's 120-volt AC output to the vehicle circuits. This generator has 30-amp breaker.

2.2 OPTIONAL REMOTE START/STOP PANEL

A remote mounted Start/Stop Panel is available that allows starting and stopping the generator engine conveniently from inside the vehicle.

Order part number OF0429 or OF0430, a remote panel that includes a Start/Stop switch, a generator run lamp, a fuel prime switch, and an hourmeter. The hourmeter provides a continuous indication of engine/generator operating time. Use the hourmeter for checking off periodic maintenance requirements on the unit.

2.3 AUTOMATIC CHOKE

The engine is equipped with an automatic choke that consists of two main components: a choke solenoid and prechoke.

2.3.1 CHOKE SOLENOID

During engine cranking (Start/Stop switch at START), a solid-state choke module signals the choke solenoid to activate and cycle (choke on/choke off) until the engine starts. The choke solenoid thus opens and closes the carburetor choke valve only when the engine is cranking. When the engine starts, the choke stops cycling.

2.3.2 PRECHOKE

The choke system also has a temperature-sensitive metal strip that adjusts choke valve angle according to ambient temperatures (i.e., in cold ambient temperatures, choke valve closes more). Once the engine starts, an element heats the temperature-sensitive strip to a normal operating condition, opening the choke valve. This may take about three minutes in cooler weather.

2.4 BEFORE STARTING THE ENGINE

NOTE:

Instructions and information in this manual assume the generator has been properly installed, connected, serviced, tested and adjusted by a qualified installation technician or installation contractor.

2.4.1 INSTALLATION

Generator installation must have been properly completed so it complies with all applicable codes, standards and regulations and with the manufacturer's recommendations.

2.4.2 ENGINE LUBRICATION

Have the engine crankcase properly serviced with the recommended oil before starting. Refer to sections "Engine Oil Requirements", "Checking the Engine Oil Level" and "Changing the Engine Oil and/or Oil Filter" for oil servicing procedures and recommendations.

⚠ CAUTION!

! Any attempt to crank or start the engine before it has been properly serviced with the recommended oil may result in an engine failure.

2.4.3 FUEL SUPPLY

The engine must have an adequate supply of proper fuel to operate. Before starting it, check that sufficient fuel is available.

NOTE:

Depending on the installation, the generator may have either a separate fuel tank, or it may “share” the vehicle engine’s fuel tank.

2.4.4 COOLING AND VENTILATING AIR

Air inlet and outlet openings in the generator compartment must be open and unobstructed for continued proper operation. Without sufficient cooling and ventilating airflow, the engine/generator quickly overheats, which causes it to shut down and may damage the generator.

2.4.5 ENGINE EXHAUST GAS

Before starting the generator engine, be sure there is no way for exhaust gases to enter the vehicle interior and endanger people or animals. Close windows, doors and other openings in the vehicle that, if open, might permit exhaust gases to enter the vehicle.

⚠ DANGER!

! The generator engine releases **DEADLY carbon monoxide gas** through its exhaust system. This dangerous gas, if breathed in sufficient concentrations, can cause unconsciousness or even death. Never operate the generator set with the vehicle inside any garage or other enclosed area. **DO NOT OPERATE THE GENERATOR IF THE EXHAUST SYSTEM IS LEAKING OR HAS BEEN DAMAGED. SYMPTOMS OF CARBON MONOXIDE POISONING ARE (a) inability to think coherently, (b) nausea, (c) vomiting, (d) twitching muscles, (e) throbbing temples, (f) dizziness, (g) headaches, (h) weakness, and (i) sleepiness. IF EXPERIENCING ANY OF THESE SYMPTOMS, MOVE INTO FRESH AIR IMMEDIATELY. IF SYMPTOMS PERSIST, GET MEDICAL HELP. Shut down the generator and do not operate it until it has been inspected and repaired.**

⚠ DANGER!

! Never sleep in the vehicle while the genset is running unless the vehicle has a working carbon monoxide detector. The exhaust system must be installed in accordance with the genset installation manual. Make sure there is ample fresh air when operating the genset in a confined area.

2.5 STARTING THE GENERATOR

NOTE:

Read the vehicle manufacturer’s instructions. The owner/operator should become familiar with the vehicle in which this generator is installed. Differences exist between vehicles. For example, some vehicles may use a transfer switch to isolate dockside power from the generator, while other vehicles may use an isolating receptacle. Some vehicles may be equipped with a DC converter, which allows the generator to power certain DC lighting and other DC loads.

To start the generator from either the generator control panel or from the optional remote panel, proceed as follows:

1. Turn OFF electrical loads using the means provided in the vehicle (such as a main line circuit breaker or transfer switch).

NOTE:

If starting from the generator control panel, turn OFF loads by setting the generator’s main circuit breaker to the OFF (or open) position. If starting from a remote panel, turn OFF loads using the means provided in the vehicle (such as a main circuit breaker). Electrical load circuits will be turned ON after the generator has started, stabilized and warmed up.

2. If the engine has not been started in more than two weeks, press the Fuel Pump Primer switch and hold it for about 10 to 15 seconds to prime the fuel system. However, if the engine is warm, skip Step 2.
3. Hold the engine Start/Stop switch in the START position to crank the engine. Release the switch when the engine starts.

⚠ CAUTION!

! If the engine does not start after it has been cranking for 15 seconds, release the Start/Stop switch, wait one minute and try again. Holding the switch for longer than 15 seconds can damage the starter motor.

4. Let the engine run at no-load for a few minutes to stabilize and warm up.
5. Turn ON electrical loads using the means provided (such as a main circuit breaker or transfer switch).

2.6 STOPPING THE GENERATOR

1. Turn OFF all electrical loads using the means provided (such as a main circuit breaker or transfer switch).
2. Let generator run at no-load for a few minutes, to stabilize internal engine generator temperatures.
3. Place the Start/Stop switch in its STOP position.

2.7 APPLYING LOADS TO GENERATOR

When applying electrical loads to the generator, observe these guidelines:

- Before applying electrical loads, let the generator stabilize and warm up for a minute or two.
- DO NOT overload the generator.

2.7.1 LETTING THE ENGINE STABILIZE

The generator supplies correct rated voltage only at the proper governed speed. Some electrical appliances may be extremely sensitive to voltage. Incorrect voltages can damage such appliances.

If electrical loads are applied at reduced operating speeds, such loads imposed on the engine when sufficient power is not available may shorten engine life. Never turn ON electrical loads until after the generator engine has started and stabilized at no-load.

2.8 DO NOT OVERLOAD THE GENERATOR

Read the rated wattage/amperage capacity of the generator on the generator data label (see "Generator Identification").

Applying electrical loads in excess of the unit's rated capacity will cause the engine/generator to automatically shut down.

To avoid overloading, add up the wattage of all connected electrical lighting, appliance, tool and motor loads. This total should not be greater than the generator's rated wattage capacity.

- Most lighting, appliance, tool and motor loads indicate their required watts on their nameplate or data plate. For light bulbs, simply note the wattage rating of the bulb.
- If a load does not show its rated wattage, multiply that load's rated VOLTS times AMPS to obtain WATTS.
- Induction type motors (such as those that run the vehicle's furnace fan, refrigerator, air conditioner, etc.) need about 2-1/2 times more watts of power for starting than for running (for a few seconds during motor starting). Be sure to allow for this when connecting electrical loads to the generator. First, figure the watts needed to start electric motors in the system. To that figure, add the running wattages of other items that will be operated by the generator.
- Do not apply heavy electrical loads for the first two or three hours of operation.

2.9 PROTECTION SYSTEMS

2.9.1 LOW OIL PRESSURE SWITCH

This switch (Figure 2.2) has normally closed (N.C.) contacts that are held open by engine oil pressure during cranking and operating. Should oil pressure drop below a preset level, switch contacts close, and the engine automatically shuts down. The unit should not be restarted until oil is added.

2.9.2 HIGH TEMPERATURE SWITCH

This switch (Figure 2.2), which has normally open (N.O.) contacts, is mounted near the oil filter. The contacts close if the temperature should exceed approximately 305° F (152° C), initiating an engine shutdown.

Figure 2.2 – Low Oil Pressure and High Temperature Switches

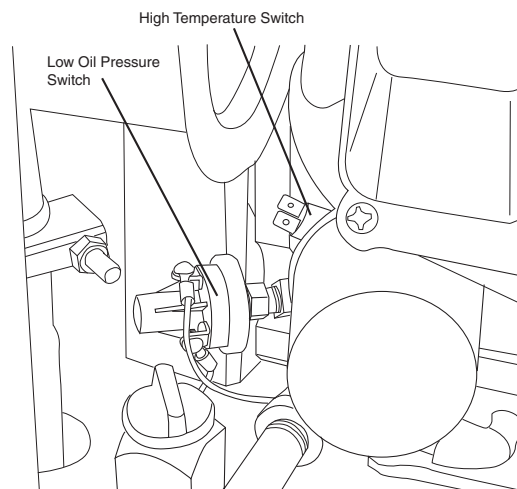

2.9.3 FIELD BOOST

The Controller Circuit Board houses a field boost diode and resistor that are not part of the automatic choke circuit. These two components are part of a "field boost" circuit (Figure 2.3). During engine cranking only, a positive DC (battery) voltage is delivered through the diode, resistor, brushes and slip rings, to the generator rotor. Application of this voltage to the rotor "flashes the field" whenever it is started. Flashing of the field each time the generator starts makes sure that a sufficiently strong magnetic field is available to produce "pickup" voltage in the stator windings.

Figure 2.3 – Field Boost Circuit

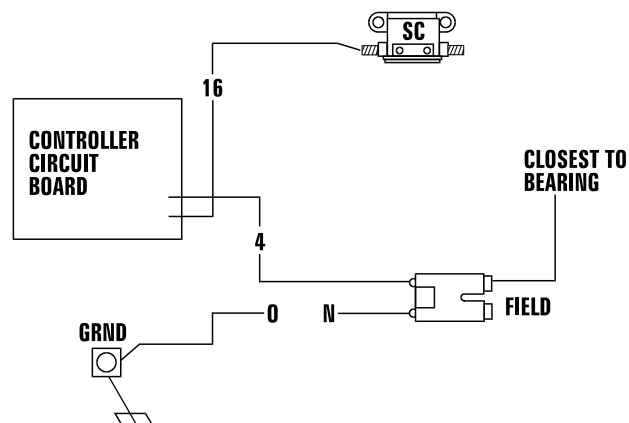

2.9.4 OVERVOLTAGE PROTECTION

A solid-state voltage regulator (Figure 2.4) controls the generator's AC output voltage. This regulator supplies an excitation current to the rotor. By regulating the rotor's excitation current, the strength of its magnetic field is regulated and, in turn, the voltage delivered to connected electrical loads is controlled. When the AC frequency is 60 Hertz, voltage is regulated at 120 volts (voltage-to-frequency ratio is 2-to-1).

Figure 2.4 – Solid State Voltage Regulator

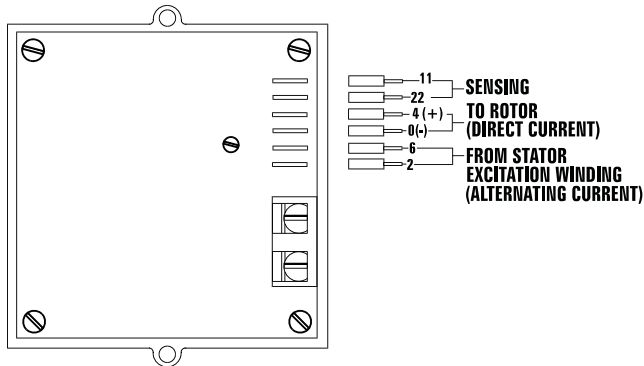

The voltage regulator also incorporates a “voltage surge protection circuit.” This circuit prevents troublesome surges in the generator AC output voltage. Voltage surge is a common cause of damage to electronic equipment.

2.10 ADDITIONAL INFORMATION

2.10.1 ATTENTION REQUIRED AFTER SUBMERSION

If the recreational vehicle generator has been submerged in water, it be started and operated. Following any submersion in water, have an Authorized Service Dealer thoroughly clean and dry the generator.

2.10.2 OPERATION IN HIGH GRASS OR BRUSH

Never operate the generator while the vehicle is parked over high grass, weeds, brush, leaves or any other combustible substance. Such materials can ignite and burn from the heat of the exhaust system. The generator exhaust system becomes extremely hot during operation and remains hot for a long time after it has shut down.

2.10.3 EFFECTS OF MOISTURE AND DIRT

Keep the generator set as clean and dry as possible. Protect the unit against excessive dust, dirt, corrosive vapors, road splash, etc. Permitting dirt and moisture to accumulate on generator windings will have an adverse effect on the insulation resistance of those windings.

When moisture is allowed to remain in contact with windings, some of the moisture will be retained in voids and cracks in the insulation. This causes a reduced insulation resistance and will eventually cause problems. Dirt will make the problem worse, since dirt tends to hold moisture in contact with windings. Salt (as from sea air) also will worsen the problem since it tends to absorb moisture from the air. Salt and moisture, when combined, form a good electrical conductor.

3.1 CHECKING THE ENGINE OIL LEVEL

For oil capacities and requirements, see “Engine Oil Requirements”. Check the engine crankcase oil level at least every eight hours of operation, or before each use. To check the engine oil level, proceed as follows (see Figure 3.1):

1. Be sure the generator is as level as possible.
2. Remove the dipstick and wipe it dry with a clean, lint-free cloth.
3. Install and tighten the dipstick cap; then, remove it again. The oil level should be at the dipstick “Full” mark.
4. If necessary, remove the oil fill cap on the rocker cover and slowly add oil until it reaches the dipstick “Full” mark. **DO NOT FILL ABOVE THE “FULL” MARK.**

▲ CAUTION!

▲ Never operate the engine with the oil level below the “Add” mark on the dipstick. Doing this could damage the engine.

5. Install and tighten the oil fill cap and the dipstick before operating the engine.

3.2 CHANGING THE ENGINE OIL AND/OR OIL FILTER

- Change the after the first 25 hours of operation. Thereafter, change the oil every 100 operating hours. Change the oil more frequently if operating consistently under heavy load or at high ambient temperatures.
 - Change the engine after the first 25 hours of operation, and every 100 operating hours thereafter.
 - To change the oil and/or oil filter, proceed as follows (see Figure 3.1):
1. Run the engine until it is thoroughly warmed up (at least five minutes) then shut OFF the engine.
 2. Immediately after the engine shuts OFF, pull the oil drain cover free of the base. Remove the plug from the tube with a 5/16” allen wrench and drain the oil into a suitable container. Loosening the oil fill cap will allow the crankcase to drain faster.
 3. After the oil has drained, replace the plug onto the end of the oil drain tube. Retain the cover in the base.
 4. With the oil drained, remove the old oil filter by turning it counterclockwise. Place a towel underneath to catch excess oil.
 5. Apply a light coating of clean engine oil to the gasket of the new filter. Fill the filter until saturated with clean oil.
 6. Screw the new filter on by hand until its gasket lightly contacts the oil filter adapter. Then, tighten the filter an additional 3/4 to one turn.
 7. Remove the dipstick and wipe it dry with a clean, lint-free cloth. This will be used later to check the oil level.
 8. Remove the oil fill cap on the oil fill tube and slowly add the proper type and amount of recommended oil (see “Engine Oil Requirements”). Periodically use the dipstick to check the oil level and continue to fill the crankcase until the oil reaches the dipstick “Full” mark. **DO NOT FILL ABOVE THE “FULL” MARK.**

Figure 3.1 – Oil Maintenance Features

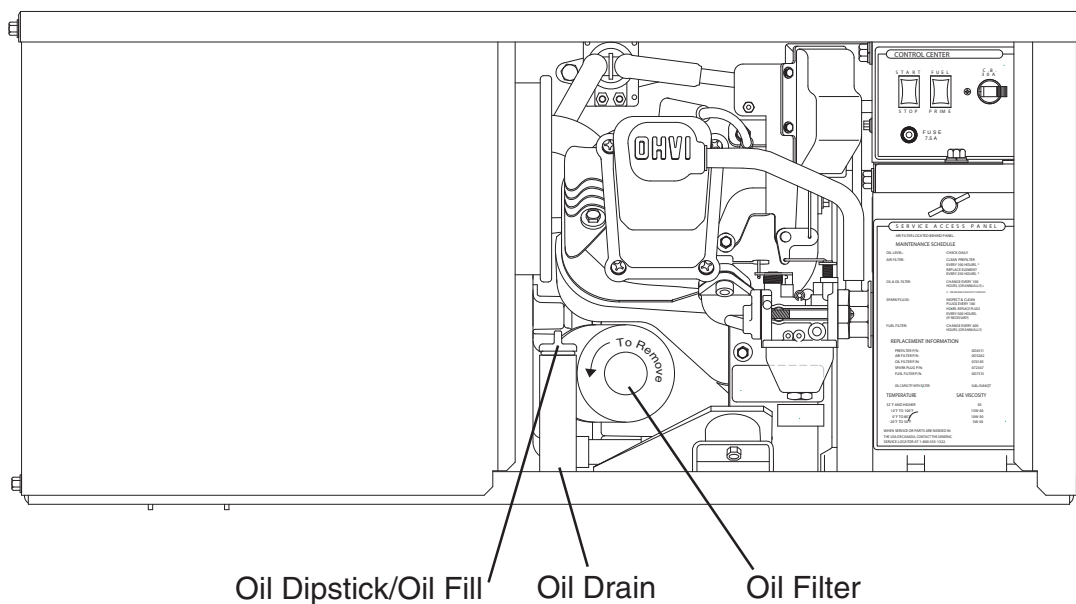

9. Install and tighten the oil fill cap and the dipstick before operating the engine.
10. Start the engine and check for leaks.

NOTE:

Check the oil level and fill to the “FULL” mark after checking for leaks. The filter will retain some oil.

3.3 MAINTAINING THE ENGINE AIR CLEANER

3.3.1 CLEANING THE FOAM PRECLEANER

Clean and re-oil the foam precleaner every three months or every 25 hours of operation, whichever occurs first. Service the foam precleaner more frequently if operating the generator in extremely dusty or dirty conditions. Use the following procedure (Figure 3.2):

1. Turn the two screws counterclockwise to loosen.
2. Remove the cover, foam precleaner and paper filter.
3. Remove the foam precleaner from the cover.
4. Wash the foam precleaner in liquid detergent and water.
5. Wrap the foam precleaner in a clean cloth and gently squeeze it dry.
6. Saturate the foam precleaner in clean engine oil. Gently squeeze it in a clean cloth to remove excess oil and to distribute oil (DO NOT TWIST).
7. Install the foam precleaner into the cover, followed by the paper filter.
8. Install the cover, foam precleaner and paper filter.
9. Tighten the two screws to retain the filter in place.

Figure 3.2 – Engine Air Cleaner

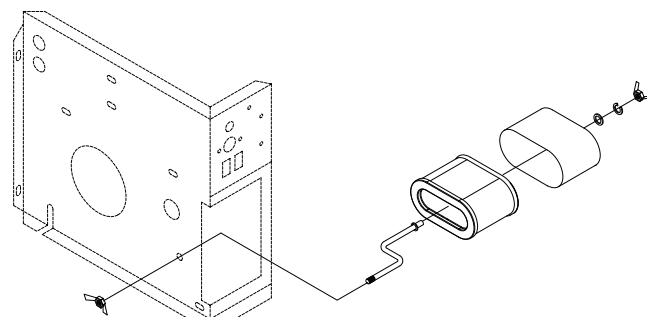

3.3.2 CLEANING OR REPLACING THE PAPER FILTER

Once each year or every 100 hours of operation (whichever comes first), clean or replace the paper filter. The new replacement filter must be flame retardant. Service the paper filter more frequently if operating the generator in extremely dusty or dirty conditions. Use the following procedure (Figure 3.2):

1. Follow steps 1-3 in "Cleaning the Foam Precleaner"; service the foam precleaner if necessary.
2. Remove the paper filter.
3. Clean the air filter by tapping it gently on a solid surface. If the filter is too dirty, replace it with a new one. Dispose of the old filter properly.
4. Clean the air cleaner cover then reassemble following steps 7-9 in section "Cleaning the Foam Precleaner".

3.4 CLEAN AIR INTAKE

Clean all foreign material from the air intake (Figure 3.3) at least once every 100 hours of operation. Clean more often if necessary.

Inspect the area around the generator exhaust muffler periodically and remove all grass, leaves, dirt, etc., from this area.

Figure 3.3 – Cleaning Air Intake

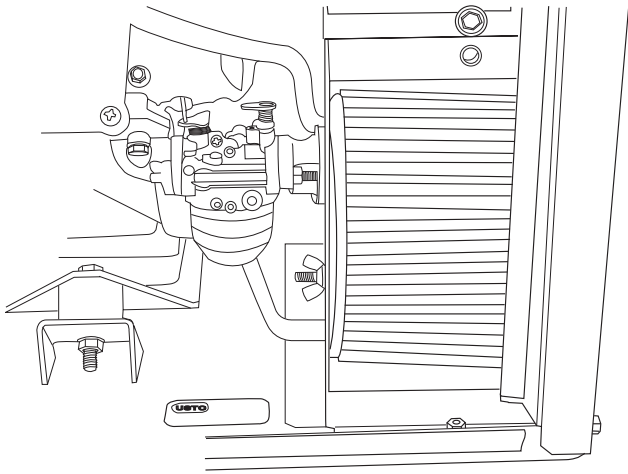

3.5 CHECKING THE ENGINE SPARK PLUG

Clean the spark plug and reset the spark plug gap every 100 hours of operation.

1. Clean the area around the base of the spark plug to keep dirt and debris out of the engine. Remove the spark plug and check the condition. Replace the spark plug if worn or if reuse is questionable.
2. Clean spark plug by scraping or washing using a wire brush and commercial solvent. Do not blast the spark plug to clean.
3. Check the spark plug gap using a wire feeler gauge. Adjust the gap to 0.030 inch (0.76 mm) by carefully bending the ground electrode (Figure 3.4).

Figure 3.4 – Setting the Spark Plug Gap

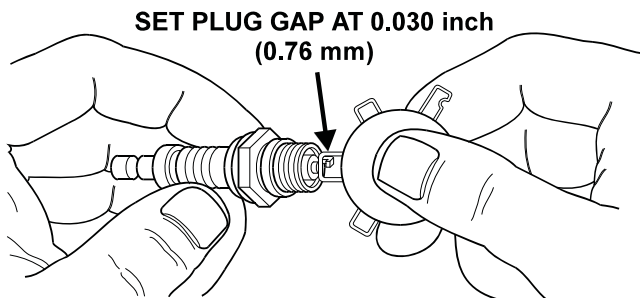

⚠ CAUTION!

⚠ Sparking can occur if the wire terminal does not fit firmly on the spark plug terminal end. If necessary, re-form the wire terminal to obtain a tight fit.

3.6 FUEL FILTER

Remove and replace the fuel filter (Figure 3.5) once each year or every 400 hours of operation, whichever comes first. Fuel filter is removed with a 15/16" deep well socket.

Figure 3.5 – Fuel Filter

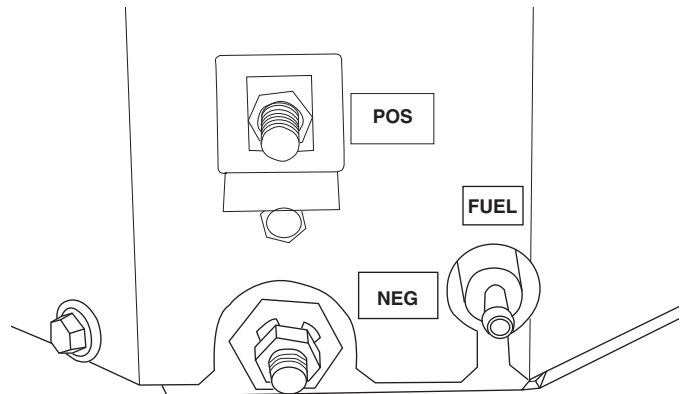

3.7 CLEAN SPARK ARRESTOR

The engine exhaust muffler has a spark arrestor screen. Inspect and clean the screen every 50 hours of operation or once each year, whichever comes first.

NOTE:

If using the generator on any forest-covered, brush-covered or grass-covered unimproved land, it must be equipped with a spark arrestor. The spark arrestor must be maintained in good condition by the owner/operator.

1. Remove the screen retaining bracket by removing the screw.
2. Slide the spark arrestor screen out from the tail pipe.
3. Inspect screen and replace if torn, perforated or otherwise damaged. **DO NOT USE** a defective screen. If screen is not damaged, clean it with commercial solvent.
4. Replace the screen and the retaining bracket.

Figure 3.6 - Spark Arrestor

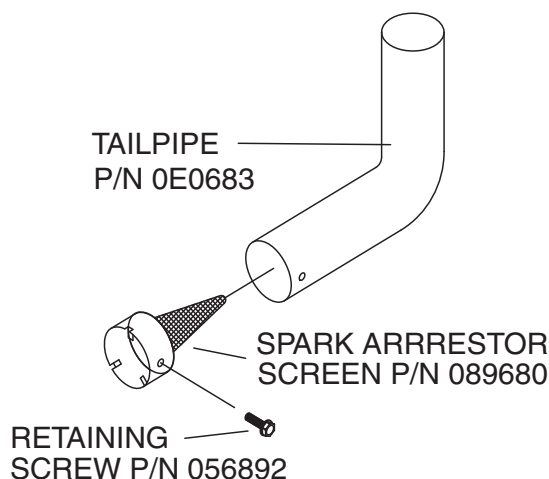

3.8 CLEANING THE GENERATOR

Keep the generator set as clean and dry as possible. Protect the unit against excessive dust, dirt, corrosive vapors, road splash, etc. Permitting dirt and moisture to accumulate on generator windings will have an adverse effect on the insulation resistance of those windings.

When moisture is allowed to remain in contact with windings, some of the moisture will be retained in voids and cracks in the insulation. This causes a reduced insulation resistance and will eventually cause problems. Dirt will make the problem worse, since dirt tends to hold moisture in contact with windings. Salt (as from sea air) also will worsen the problem since it tends to absorb moisture from the air. Salt and moisture, when combined, form a good electrical conductor which can be damaging to the generator windings.

⚠ CAUTION!

⚠ **Do NOT use a forceful spray of water to clean the generator. Water will enter the generator interior and cause problems, and may also contaminate the generator fuel system.**

3.9 BATTERY MAINTENANCE

All lead-acid batteries will discharge when not in use. The generator battery should be inspected as follows:

3.9.1 WEEKLY

- Inspect the battery posts and cables for tightness and corrosion. Tighten and clean as necessary.
- Check the battery fluid level of unsealed batteries and, if necessary, fill with Distilled Water Only. Do not use tap water in batteries.

3.9.2 EVERY SIX MONTHS

- Have the state of charge and condition checked. This should be done with an automotive-type battery hydrometer.

Note:

Servicing of the battery is to be performed or supervised by personnel knowledgeable of batteries and the required precautions. Keep unauthorized personnel away from batteries.

Damage will result if the battery connections are made in reverse.

⚠ DANGER!

⚠ **Do not dispose of the battery in a fire. The battery is capable of exploding. Storage batteries give off explosive hydrogen gas. This gas can form an explosive mixture around the battery for several hours after charging. The slightest spark can ignite the gas and cause an explosion. Such an explosion can shatter the battery and cause blindness or other injury. Any area that houses a storage battery must be properly ventilated. Do not allow smoking, open flame, sparks, or any spark producing tools or equipment near the battery. Discharge static electricity from body before touching the battery by first touching a grounded metal surface.**

⚠ **A battery presents a risk of electrical shock and high short circuit current. The following precautions are to be observed when working on batteries:**

- Remove watches, rings or other metal objects;
- Use tools with insulated handles;
- Wear rubber gloves and boots;
- Do not lay tools or metal parts on top of the battery;
- Disconnect any charging source prior to connecting or disconnecting battery terminals;
- Do not use any jumper cables or booster battery to crank and start the generator engine. If any battery has discharged, remove it for recharging.

⚠ WARNING!

⚠ **Do not open or mutilate the battery. Released electrolyte has been known to be harmful to the skin and eyes, and to be toxic.**

⚠ **The electrolyte is a dilute sulfuric acid that is harmful to the skin and eyes. It is electrically conductive and corrosive. The following procedures are to be observed:**

- Wear full eye protection and protective clothing;
- Where electrolyte contacts the skin, wash it off immediately with water;

Maintenance

- **Where electrolyte contacts the eyes, flush thoroughly and immediately with water and seek medical attention;**
- **Spilled electrolyte is to be washed down with an acid neutralizing agent. A common practice is to use a solution of 1 pound (500 grams) bicarbonate of soda to 1 gallon (4 liters) or water. The bicarbonate of soda solution is to be added until the evidence of reaction (foaming) has ceased. The resulting liquid is to be flushed with water and the area dried.**

3.10 MAJOR SERVICE MANUAL

To obtain a service manual for the generator, contact the nearest Authorized Service Dealer. Make sure to identify the MODEL NUMBER and SERIES.

3.11 EXERCISING THE GENERATOR

The manufacturer recommends that the generator be started and operated at least once every seven days. Let the unit run for at least 30 minutes to “exercise” the engine.

3.12 OUT OF SERVICE PROCEDURE

3.12.1 REMOVAL FROM SERVICE

If the generator cannot be exercised every seven days, and it is to be out of service longer than 30 days, prepare the generator for storage as follows:

1. Start the engine and let it warm up.
2. Close the fuel shutoff valve in the fuel supply line and allow the unit to shut down.

Note:

Using a fuel additive such as STA-BIL fuel stabilizer, or an equivalent, will prevent gum deposits from forming in the engine’s fuel system.

3. While the engine is still warm from running, drain the oil completely. Refill the crankcase with SAE 10W-30 oil having API classification “For Service SF.”
4. Attach a tag to the engine indicating the viscosity and classification of the oil in the crankcase.
5. Remove the spark plug and pour two or three tablespoons of clean, fresh engine oil into the spark plug threaded openings. Reinstall and tighten the spark plug.
6. Remove the battery and store it in a cool, dry room on a wooden board. Never store the battery on any concrete or earthen floor.
7. Clean and wipe the entire generator.

3.12.2 RETURN TO SERVICE

To return the unit to service after storage, proceed as follows:

1. Check the tag on the engine for oil viscosity and classification. Verify that the correct recommended oil is used in the engine (see “Engine Oil Requirements”). If necessary, drain and refill with the proper oil.
2. Check the state of the battery. Fill all cells of unsealed batteries to the proper level with distilled water. **DO NOT USE TAP WATER IN THE BATTERY.** Recharge the battery to 100 percent state of charge, or, if defective, replace the battery.
3. Clean and wipe the entire generator.
4. Reconnect the battery. Observe battery polarity. Damage may occur if the battery is connected incorrectly.
5. Turn OFF all electrical loads. Add fuel if necessary and then start the engine.
6. Allow the unit to run for several minutes to warm up.
7. Apply electrical loads to at least 50 percent of the unit’s rated wattage capacity.
8. When the engine is thoroughly warmed up, shut it down.
9. The generator is now ready for service.

3.13 ADJUSTING VALVE CLEARANCE

After the first 50 hours of operation, adjust the valve clearance in the engine.

When adjusting valve clearance, the engine should be at room temperature and the piston should be at Top Dead Center (TDC) of its compression stroke (both valves closed). Correct clearance is 0.001-0.003 inch (0.03-0.07mm). Adjust valve clearance as follows:

1. Loosen the rocker arm jam nut. Use an allen wrench to turn the pivot ball stud while checking clearance between the rocker arm and the valve stem with a feeler gauge (Figure 3.7).

Figure 3.7 — Adjusting Valve Clearance

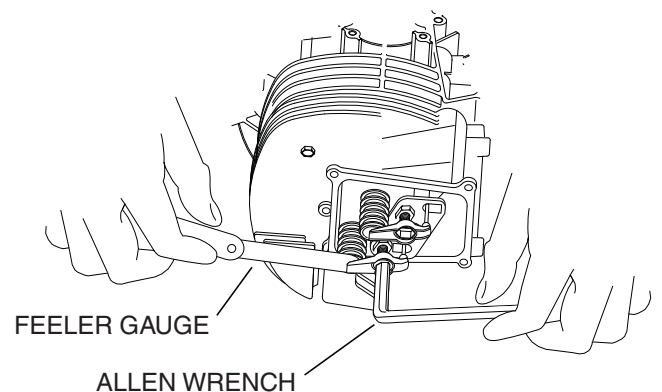

2. When valve clearance is correct, hold the pivot ball stud with the allen wrench and tighten the rocker arm jam nut with a crows foot. Tighten the jam nut to 65-85 inch-pounds torque. After tightening the jam nut, recheck valve clearance to make sure it did not change (Figure 3.8).

Figure 3.8 — Tightening Jam Nut

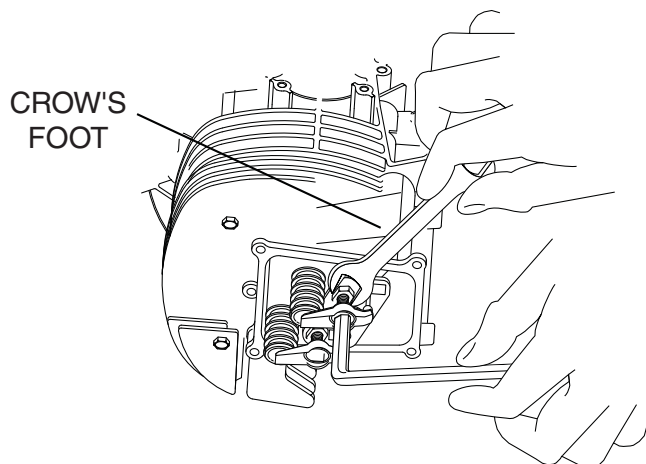

3.14 RV GENERATOR SERVICE INTERVAL

50 Hours	Clean Spark Arrestor
100 Hours	Change Engine Oil/filter
100 Hours	Clean Air Pre-filter
100 Hours	Inspect Spark Plugs
250 Hours	Replace Paper Air Filter Element
400 Hours	Replace Fuel Filter
500 Hours	Replace Spark Plugs
1st 50 Hours-then every 500 Hrs.	Adjust Valve Lash

PART II – INSTALLATION INSTRUCTIONS

⚠ DANGER!

**ONLY QUALIFIED ELECTRICIANS OR CONTRACTORS
SHOULD ATTEMPT INSTALLATION!**

Safety Rules

! DANGER: For fire safety, installation of a generator into a recreational vehicle must comply strictly with article 551, NFPA 70; ANSI C1-1975; AND, ANSI A119.2-1975/NFPA 501C “Standard for Recreational Vehicles” (Part 3, “Installation of Electrical Systems”). In addition, installation must comply with the manufacturer’s instructions and recommendations.

NOTICE TO INSTALLER

These *Installation Instructions* have been published by the manufacturer to aid in the installation of the products described in this manual. The manufacturer assumes that installation personnel are familiar with the procedures for installing such products, or similar products manufactured. The manufacturer also assumes that personnel have been trained in the recommended installation procedures for these products and that such training includes (a) use of common hand tools, (b) use of special tools, and (c) use of any tools and/or equipment from other suppliers.

The manufacturer cannot possibly know of and advise the recreational vehicle trade of all conceivable methods, procedures or techniques by which to perform an installation. Nor can we anticipate every possible hazard that might result from each installation method, procedure or technique. The manufacturer has not undertaken any such wide evaluation. Therefore, people who use a method, procedure or technique that the manufacturer does not specifically recommend must first completely satisfy themselves that their safety, the safety of the vehicle's occupants and the product's safety is not endangered by the method, procedure or technique selected.

Information, illustrations, specifications, etc., contained in these *Installation Instructions* are based on the latest information available at the time of publication. Every effort has been expended to be sure that such data is both accurate and current. However, the manufacturer reserves the right to change, alter or otherwise improve this product at any time without prior notice.

! DANGER!

! Despite the safe design of this generator, operating this equipment imprudently, neglecting its maintenance or being careless can cause possible injury or death. Permit only responsible and capable persons to operate or maintain this equipment.

! Potentially lethal voltages are generated by these machines. Ensure all steps are taken to render the machine safe before attempting to work on the generator.

! Parts of the generator are rotating and/or hot during operation. Exercise care near running generators.

GENERAL HAZARDS

- For safety reasons, the manufacturer recommends that the installation, initial start-up and maintenance of this equipment is carried out by an Authorized Service Dealer.
- The engine exhaust fumes contain carbon monoxide, which can be DEADLY. This dangerous gas, if breathed in sufficient concentrations, can cause unconsciousness or even death. This exhaust system must be installed properly, in strict compliance with applicable codes and standards. Following installation, do nothing that might render the system unsafe or in noncompliance with such codes and standards. The generator compartment must be completely vapor sealed from the vehicle interior. There must be no possibility of exhaust fumes entering the vehicle interior. Never operate this equipment with a leaking or defective exhaust system.
- Keep hands, feet, clothing, etc., away from drive belts, fans, and other moving or hot parts. Never remove any drive belt or fan guard while the unit is operating.
- Adequate, unobstructed flow of cooling and ventilating air is critical to correct generator operation and is required to expel toxic fumes and fuel vapors from the generator compartment. Without sufficient cooling airflow, the engine/generator quickly overheats, which causes serious damage to the generator. Do not alter the installation or permit even partial blockage of ventilation provisions, as this can seriously affect safe operation of the generator.
- When working on this equipment, remain alert at all times. Never work on the equipment when physically or mentally fatigued.
- Before performing any maintenance on the generator, disconnect its battery cables to prevent accidental start up. Disconnect the cable from the battery post indicated by a NEGATIVE, NEG or (-) first. Reconnect that cable last.
- Never use the generator or any of its parts as a step. Stepping on the unit can stress and break parts, and may result in dangerous operating conditions from leaking exhaust gases, fuel leakage, oil leakage, etc.
- Never insert any tool or other object through openings in the generator interior, even if the unit is not running. Serious injury or damage to the equipment may occur.

ELECTRICAL HAZARDS

- The generator covered by this manual produces dangerous electrical voltages and can cause fatal electrical shock. Avoid contact with bare wires, terminals, connections, etc., while the unit is running. Ensure all appropriate covers, guards and barriers are in place before operating the generator. If work must be done around an operating unit, stand on an insulated, dry surface to reduce shock hazard.
- Do not handle any kind of electrical device while standing in water, while barefoot, or while hands or feet are wet. **DANGEROUS ELECTRICAL SHOCK MAY RESULT.**
- During installation onto the vehicle, properly ground (bond) the generator either by solid mounting to the vehicle frame or chassis, or by means of an approved bonding conductor. **DO NOT** connect the bonding conductor to any generator part that might be removed or disassembled during routine maintenance. If the grounding conductor must be replaced, use only a flexible conductor that is of No. 8 American Wire Gauge (AWG) copper wire minimum.
- If the vehicle electrical circuits can be powered by any other source of electricity (such as a “dockside” power receptacle), there must be no possibility of connecting the different power sources to the vehicle circuits at the same time. The dockside (utility) power source must be positively isolated from the vehicle circuits whenever the generator is operating. Failure to isolate the vehicle circuits from the dockside power supply when the generator is running may result in damage to the generator or serious injury or death to dockside (utility) power workers due to backfeed of electrical energy.
- In case of accident caused by electric shock, immediately shut down the source of electrical power. If this is not possible, attempt to free the victim from the live conductor. **AVOID DIRECT CONTACT WITH THE VICTIM.** Use a nonconducting implement, such as a rope or board, to free the victim from the live conductor. If the victim is unconscious, apply first aid and get immediate medical help.
- Never wear jewelry when working on this equipment. Jewelry can conduct electricity resulting in electric shock, or may get caught in moving components causing injury.

FIRE HAZARDS

- For fire safety, the generator must be installed and maintained properly. Installation always must comply with applicable codes, standards, laws and regulations. Adhere strictly to local, state and national electrical and building codes. Comply with regulations the Occupational Safety and Health Administration (OSHA) has established. Also, ensure that the generator is installed in accordance with the manufacturer’s instructions and recommendations. Following proper installation, do nothing that might alter a safe installation and render the unit in noncompliance with the aforementioned codes, standards, laws and regulations.
- Keep a fire extinguisher in the vehicle at all times. Extinguishers rated “ABC” by the National Fire Protection Association are appropriate for use on the recreational vehicle generator electrical system. Keep the extinguisher properly charged and be familiar with its use. If there are any questions pertaining to fire extinguishers, consult the local fire department.

EXPLOSION HAZARDS

- Do not smoke around the generator. Wipe up any fuel or oil spills immediately. Ensure that no combustible materials are left in the generator compartment, or on or near the generator, as **FIRE** or **EXPLOSION** may result. Keep the area surrounding the generator clean and free from debris.
- Gasoline is extremely **FLAMMABLE** and its vapors are **EXPLOSIVE**. Do not permit smoking, open flame, sparks or any source of heat in the vicinity while handling gasoline. Comply with all laws governing the storage and handling of gasoline.
- Fuel lines must be properly installed and fastened, and free of leaks. There must be no possibility of gasoline vapors entering the vehicle interior.
- It is required to install an approved, flexible, nonconductive fuel line between the generator fuel connection point and rigid fuel lines.

General Information

1.1 PURPOSE AND SCOPE OF THE MANUAL

These *Installation Instructions* have been prepared especially for the purpose of familiarizing installers and owners of the applicable equipment with the product's installation requirements. Give serious consideration to all information and instructions in the manual, both for safety and for continued reliable operation of the equipment.

Because of the different recreational vehicle models and the variations between the models, it would be extremely difficult, if not impractical, to provide detailed instructions for every possible installation. For that reason, instructions and illustrations in this manual are general in nature. Illustrations are not intended to serve as detailed installation blueprints.

The installation should comply strictly with all applicable codes, standards and regulations pertaining to the installation and use of this product. If any portion of this manual appears to be in conflict with such codes, standards or regulations, the applicable codes, standards or regulations must take precedence over the manual.

1.2 SAFETY

Before handling, installing, operating or servicing this equipment, carefully read the "Notice to Installer" and "Safety Rules". Comply with all safety rules to prevent death, personal injury or damage to equipment and/or property. Stress safety to all installers, operators and service technicians who work on this equipment.

1.3 STANDARDS BOOKLETS

Installation, use and servicing of this equipment should comply strictly with published standards, as well as the manufacturer's recommendations. The following standards booklets (latest revision) are available from the sources indicated:

1. NFPA Standard 501C, "Standard for Recreational Vehicles," available from the National Fire Protection Association, Batterymarch Park, Quincy, MA 02269.
2. NFPA 70, "NFPA Handbook of the National Electric Code," available same as Item 1.
3. ANSI C1-1975 and ANSI 119.2-1975, available from the American National Standards Institute, 1430 Broadway, New York, NY 10018.
4. ANSI A119.2/NFPA 501C, available from the Recreational Vehicle Association, 1896 Preston White Drive, Reston, VA 22090.
5. California Administrative Code, Title 25, available from the State of California, Documents Section, P.O. Box 1015, North Highlands, CA 95660.
6. CSA Electrical Bulletin 946, available from the Canadian Standards Association, Housing and Construction Materials Section, 178 Rexdale Boulevard, Rexdale, Ontario, Canada, M9W 1R3.

1.4 EQUIPMENT DESCRIPTION

Instructions and information in this section pertain to air-cooled generators. This generator is designed specifically for installing in recreational vehicles. This generator operates 120-volts, single-phase, 60-Hertz, AC electrical loads that require 30.0 amps.

1.5 GENERATOR ENGINE OPERATING SPEED

The generator's revolving field (rotor) is driven by a single-cylinder, four-cycle engine. The generator supplies 120 volts AC at 60 Hertz when the rotor is operating at 3,600 rpm.

1.6 GENERATOR AC CONNECTION SYSTEM

The generator is equipped with dual stator power windings as shown in Figure 1.1.

Figure 1.1 – 120-volt Single Voltage Connection

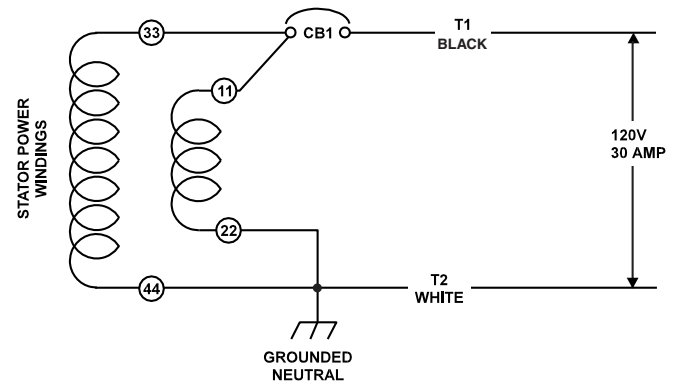

- The AC connection system on air-cooled generators uses a GROUNDED neutral.
- A separate green ground wire is connected to the recreational vehicle's junction box.

NOTE:

Do NOT connect loads in excess of circuit breaker ratings.

Figure 1.2 – Major Features and Dimensions (Drawing No. 0D8716-K)

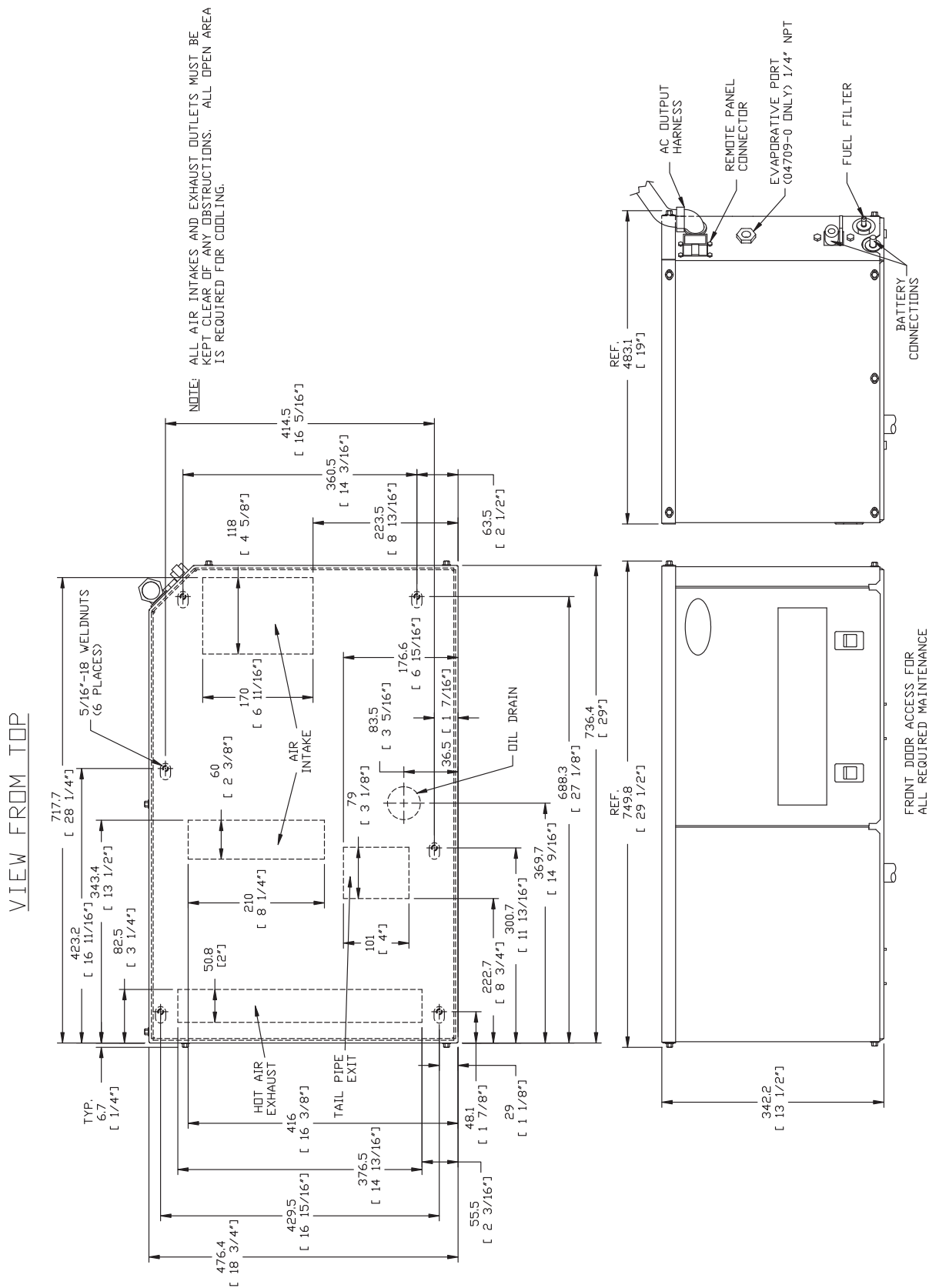

Installation

2.1 LOCATION AND SUPPORT

2.1.1 GENERATOR LOCATION

The most desirable location for the generator set is between the vehicle's main frame members. However, this is seldom possible. Most units must be installed on the side of the vehicle and are difficult to reinforce.

Many recreational vehicles have been factory equipped with an area for the generator set. Some vehicles may even have a generator compartment provided by the vehicle manufacturer.

Plan the generator location based on the following:

- The generator set must be installed on a framework that is part of the recreational vehicle, as outlined in the "Generator Support" section.
- The location must provide an access opening that is large enough to permit generator removal (unless the generator is to be removed from underneath the supporting framework).
- The location must provide easy access to frequently serviced components, such as filters, oil drains, spark plugs and other common maintenance parts.
- The location must provide sufficient room to allow minimum clearances as outlined in "Generator Compartments". If sound insulation is to be used on the compartment walls and ceiling, the minimum recommended applies to the space between the generator and such insulation.
- The location must provide adequate cooling and ventilating airflow for the generator without a great deal of work and expense.
- If mounting the generator in an enclosed compartment, the base of the generator must rest flat on the floor without any gaps.
- When using a suspended mounting system, ensure the base of the generator is flush with the surrounding bodywork. If the unit is mounted higher in the structure, heated air may recirculate into the generator causing it to overheat.

2.1.2 GENERATOR SUPPORT

The generator must be securely attached to a metal framework that has been made part of the vehicle frame structure by bolting or welding. The metal framework on which the generator will rest and which will restrain the generator set should consist of at least two horizontal beams. These beams should consist of (a) 1-1/2-inch square, 11-gauge steel tubing OR (b) 1-1/2-inch, 11-gauge angle iron. A typical supporting frame with horizontal support tubing, is shown in Figure 2.1.

The generator can be installed so that it sits on top of the horizontal support tubing if the vehicle design permits. Another method is to suspend the generator below the horizontal support tubing by means of suitable, structurally sound metal framework. The following general rules apply:

- Vehicle construction **MUST** be capable of supporting the weight of the generator.
- Whether the generator is mounted above the horizontal support tubing or suspended below the tubing, the supporting frame used must be structurally sound.

- If the generator cannot be bolted directly to the supporting frame or support tubing, consider using additional tubing, angle brackets or other supports to give the supporting frame sufficient strength.

Figure 2.1 – Typical Horizontal Support Frame

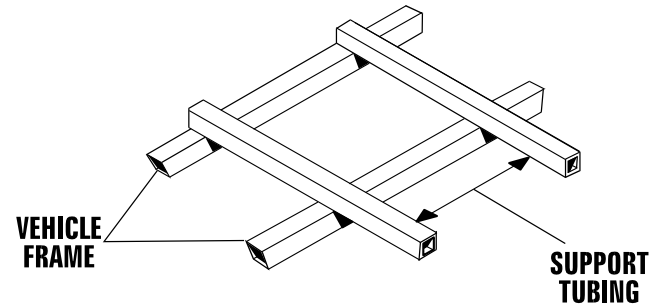

2.1.3 SUSPENDED MOUNTING

If the generator will be suspended below the horizontal support tubing, the suspension method used with the vehicle frame members must (a) be able to support the weight of the generator AND (b) provide sufficient restraint for the generator. One typical suspended mounting system is shown in Figure 2.2. The location of a suspended mounting system must be carefully planned, keeping the following general rules in mind:

- Protect the generator against road splash and debris. Baffles or splash guards may be required to protect certain areas of the generator. To make sure the generator is adequately protected, road test the installation through mud, water and slush.
- The installer must make certain that the selected location will permit adequate cooling and ventilating airflow to be supplied.

Figure 2.2 – Typical Suspended Mounting System

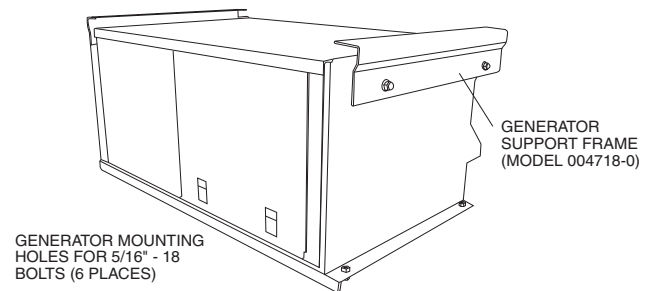

2.1.4 GENERATOR RESTRAINT

Use four 5/16"-18 hardened steel bolts (Grade 5) to fasten the generator to the supporting frame or the support tubing. These bolts must pass through (a) the generator mounting base, (b) the compartment floor (if a compartment is used) and (c) the supporting framework (Figure 2.3). All bolts must be long enough so that when tight, at least three threads are visible past the retaining lock nuts. Refer to "Generator Compartments" for the location of the generator mounting holes.

Figure 2.3 – Typical Generator Restraint

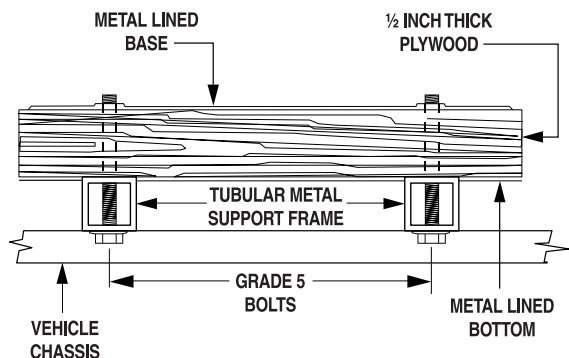

2.2 GENERATOR COMPARTMENTS

Whether the generator set is being installed inside a compartment specifically manufactured to house a generator or inside a compartment that the installer constructs, the compartment must meet certain specifications as outlined in the following sections:

2.2.1 COMPARTMENT SIZE

Plan the compartment size carefully. Provide a minimum clearance of 1/2 inch (13 mm) on the front and top, one (1) inch (25 mm) on the sides, and one (1) inch (25 mm) from the back for air circulation AFTER the compartment has been lined with metal and sound insulation (Figure 2.4).

Figure 2.4 – Clearances

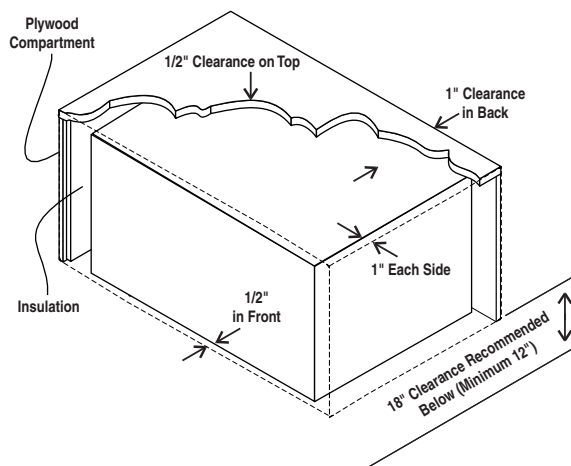

NOTE:

Refer to “Figure 1.2 – Major Features and Dimensions”.

2.2.2 COMPARTMENT CONSTRUCTION

- The generator compartment should be either constructed of, or lined with, 26-gauge galvanized steel.

NOTE:

Aluminum is **NOT** an acceptable alternative to galvanized steel due to aluminum’s low melting point.

- If the compartment is lined with galvanized steel, it may be constructed of any material. The manufacturer recommends that the compartment be constructed of 1/2-inch thick plywood (not strandboard), with the floor made of a double thickness of 1/2-inch plywood with the grain of the wood at cross section for added strength (Figure 2.5).

Figure 2.5 – Typical Compartment Construction

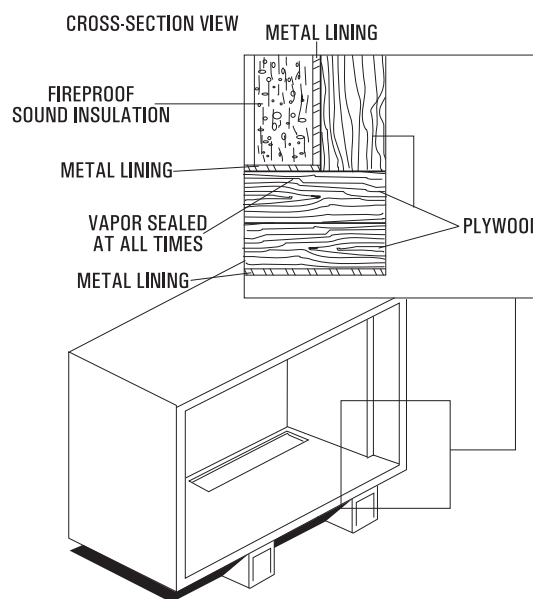

- If constructing a compartment, line the exterior (underside) of the compartment floor with 26-gauge galvanized steel.
- All seams, splices and joints of the compartment walls (unless vapor tight by design) should be caulked to prevent poisonous, flammable or explosive vapors from entering the vehicle interior.

NOTE:

Caulking must be done so that the caulking material will stay in place permanently. Pressing such materials as putty tape onto joints and seams is NOT acceptable. A high quality silicone rubber base sealant is recommended.

- Holes and openings made in the compartment walls to allow for the passage of electrical conduit, conductors, hoses, cables, etc., into the vehicle living area must be sealed vapor tight with silicone rubber base sealant.
- If flexible metal conduit is used, it must be sealed internally at the end where it terminates inside the compartment’s electrical junction box.

NOTE:

Flexible metal conduit, due to its unique construction, is NOT vapor tight along its entire length.

- Seams and joints of the galvanized steel (whether used as a liner or for the compartment itself) must be lapped and mechanically secured. Such seams may be manufactured, welded, bolted, riveted or screwed. Manufactured lock seams are shown in Figure 2.6. Installer constructed compartments typically utilize a standard lap joint.

Installation

Figure 2.6 – Types of Lock Seams

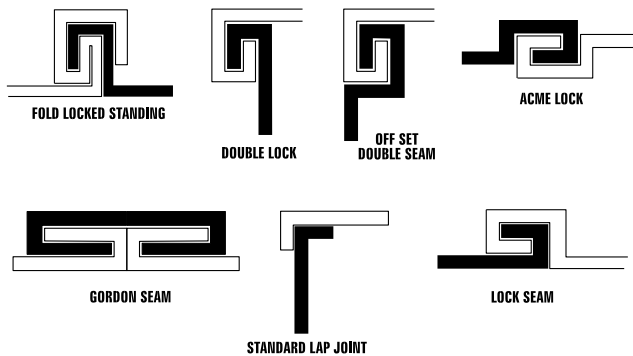

- After the compartment has been metal lined and vapor sealed, line the compartment interior walls and ceiling with an approved, nonflammable sound insulating material (see "Sound Insulating Materials").

⚠ DANGER!

⚠ Do not install any flammable material directly above or around the compartment. Heat, transferred through the compartment structure, may be sufficient to ignite, char or discolor seat cushions, fiberboard and other flammable materials. Use approved nonflammable insulating materials in high temperature areas.

2.2.3 SOUND INSULATING MATERIALS

Once installers have determined that a compartment is properly constructed and metal lined, they can add acoustical material. This may include additional sealant or insulating material, to reflect noise away from the vehicle interior.

Sound insulating materials should be of a nonflammable type. One excellent insulating material is a 1-inch (25 mm) thick fiberglass having a 2-pound density. When fiberglass is used, its coated side should face toward the compartment interior.

⚠ DANGER!

⚠ Do not install sound insulation or any absorbent material on the compartment floor interior. Such materials will become soaked with combustible or explosive vapors and liquids and will become a fire hazard.

Using a combination of sound insulating materials can often reduce noise more effectively than a single material. For example, a sheet of lead or visco-elastic material, along with a layer of other acoustical material, is more effective than when a single material is used.

2.2.4 ACOUSTICS

For additional noise abatement, the installer may wish to consider the following:

- Using special sound insulating materials.
- Construction of a special noise abatement compartment.

NOTE:

Any method used to reduce noise must not adversely affect the flow of cooling and ventilating air into or out of the compartment.

In addition to the effective use of sound insulating materials, construction of a special noise abatement compartment might be considered to reduce noise levels. Such a compartment might be constructed as follows (Figure 2.7):

- Use 5/8-inch thick or 3/4-inch thick plywood in the compartment.
- Construct the compartment floor of a double thickness of 5/8-inch or 3/4-inch plywood.

Figure 2.7 – Typical Noise Abatement

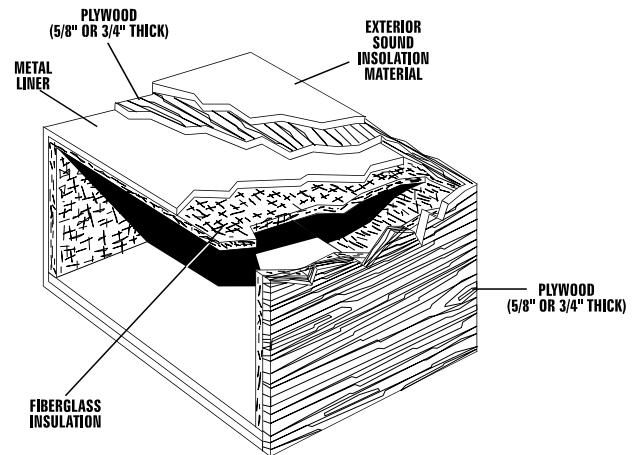

- Line the compartment interior walls and floor, as well as the underside of the floor, with 26-gauge galvanized steel.
- Vapor seal all compartment seams and joints.
- Over the galvanized steel lining, install a combination of acoustical materials as mentioned in "Sound Insulating Materials".

⚠ DANGER!

⚠ To prevent fire or explosion, do not install any insulation or other absorbent materials on the interior or underside of the compartment floor.

- Seal all compartment door edges to prevent noise leakage around the door perimeter.
- Line the compartment door interior (except for air openings) with suitable, fireproof sound insulation (such as 1-inch (25 mm) thick fiberglass with a 2-pound density).

2.2.5 COMPARTMENT FLOOR CUTOUTS

Provide openings in the generator compartment for the following items (Figure 2.8 on page 26):

- Engine exhaust and cooling air outlets
- Generator cooling air inlet
- Four holes for passage of generator mounting bolts (see "Generator Restraint").

Figure 2.8 – Compartment Floor Cutout (Drawing OG3723-A)

VIEW FROM TOP

DIMENSIONS ARE IN MM [INCHES]

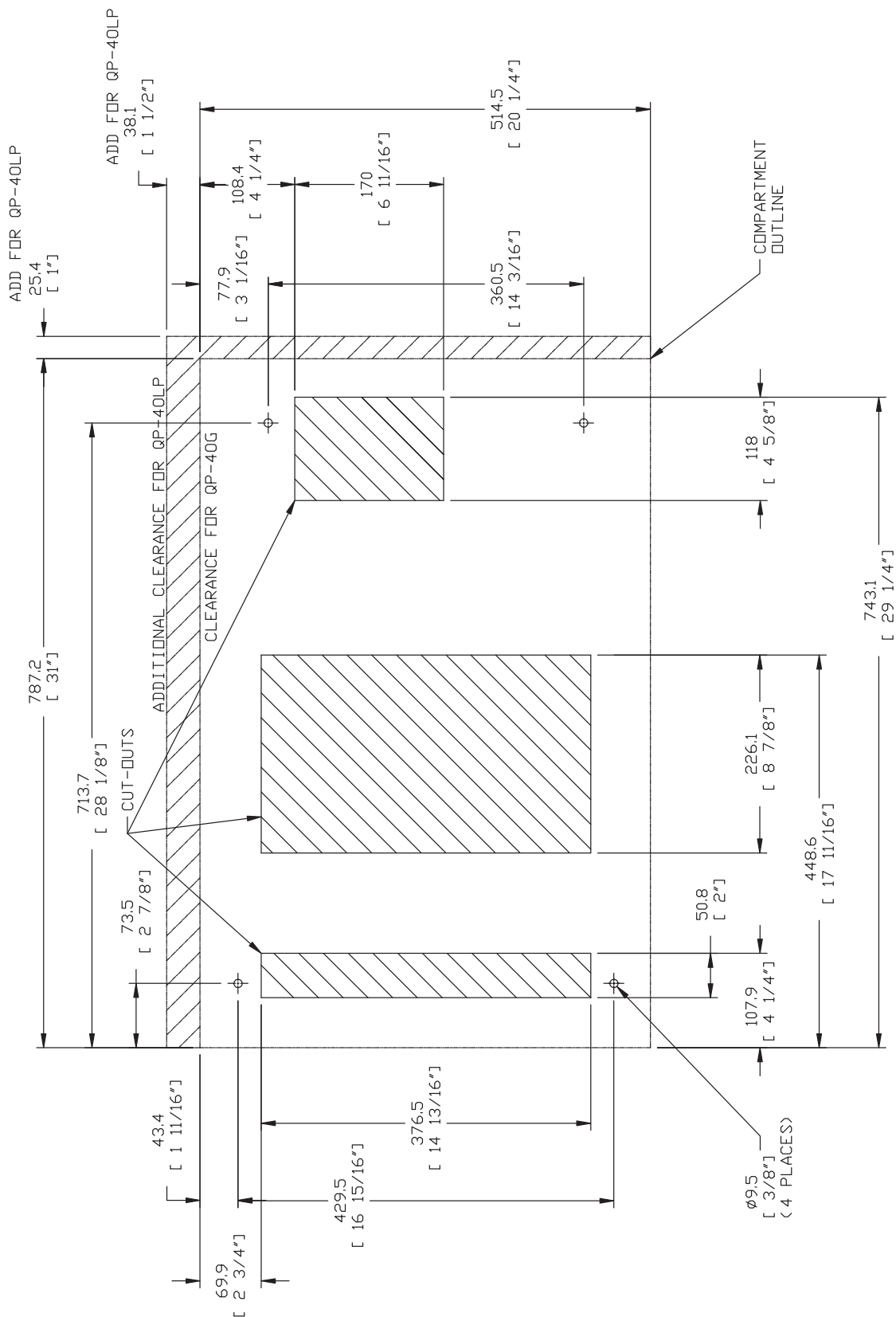

CONTACT GUARDIAN RV SALES:
RVtemplates@generac.com
FOR A FULL SIZE
INSTALLATION TEMPLATE

NOTE: ALL AIR INTAKES AND EXHAUST OUTLETS MUST BE
KEPT CLEAR OF ANY OBSTRUCTIONS. ALL OPEN AREA
IS REQUIRED FOR COOLING.

Installation

⚠ DANGER!

⚠ Fuel lines and exhaust piping must not penetrate into the vehicle living area.

2.3 COOLING AND VENTILATING AIR

It is absolutely essential that an adequate flow of air for cooling, ventilating and engine combustion be supplied to the generator set. Without sufficient airflow, the engine/generator quickly overheats. Such overheating can cause serious operating difficulties and also may cause fire and personal injury. The installer must make sure that sufficient air is available to the generator for cooling, ventilating and combustion. The installer also must provide for a path for exhausting the cooling air to the exterior of a compartment, if so equipped.

⚠ DANGER!

⚠ Never use discharged cooling air for heating or permit such air to enter the vehicle interior. This air contains deadly carbon monoxide gas and other poisonous, flammable or explosive gases.

2.3.1 GENERATOR AIRFLOW

Engine operation drives cooling fans for the two-stage cooling air system. A pressure fan draws cooling air into the bottom right side of the generator (Figure 2.9). This airflow cools the engine/generator and electronic components. The second part of the cooling system, a suction fan, draws air that is heated from a hot engine into a collector compartment at the left side of the unit. This heated air (although cooler than exhaust muffler) is then deflected out the bottom toward the ground.

Figure 2.9 – Airflow Through Engine/Generator



2.3.2 TESTING THE INSTALLATION

The manufacturer recommends testing the installation to be sure adequate cooling airflow is available to the unit before placing the unit into service. If the unit shows signs of overheating, enlarge the air openings. Never place a unit into service until absolutely certain that cooling and ventilation is adequate.

NOTE:

Test the installation, especially if bringing in air from below the generator set.

2.4 GASOLINE FUEL SYSTEM

The installation of a gasoline fuel system (Figure 2.10) for a recreational vehicle generator set must comply with applicable codes, standards and regulations. The entire fuel system must be completely free of leaks. There must be no possibility of gasoline vapors entering the vehicle interior.

Figure 2.10 – Generator Fuel System

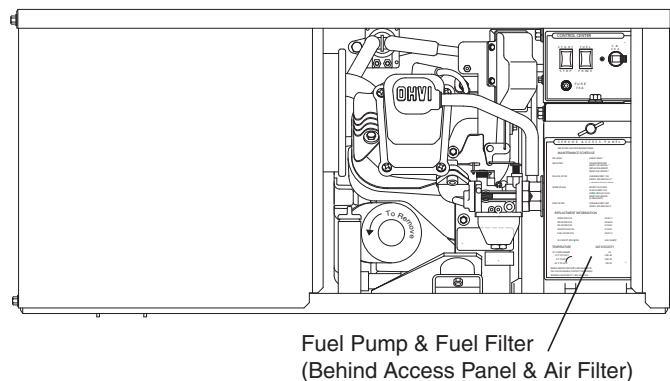

⚠ DANGER!

⚠ Gasoline is highly flammable, and its vapors are explosive. Comply with all codes, standards and regulations pertaining to gasoline fuel systems used in recreational vehicle generators. Properly install and maintain the fuel system and keep it entirely free of leaks. Gasoline vapors must not enter the vehicle interior.

Factory installed generator fuel system components include (a) fuel filter, (b) 12-volt DC electric pump, (c) engine carburetor, and (d) interconnecting lines and fittings. Connect a fuel supply line to the fuel filter inlet. Use a flexible length of approved fuel hose between the fuel filter inlet connection and rigid fuel lines.

2.4.1 FUEL TANK

Either the generator must share the vehicle engine's fuel tank, or install a separate fuel tank for the generator set. All fuel tanks installed on the vehicle must be constructed, installed and restrained so they comply with applicable codes, standards and regulations.

If the generator is to share the vehicle engine's tank, separate fuel pickup tubes are required for the engine and the generator. The manufacturer recommends that the fuel pickup tube be 2 to 3 inches (51 to 76 mm) shorter than the vehicle engine's pickup tube. This prevents the generator from depleting the entire fuel supply during prolonged generator operating periods.

⚠ CAUTION!

⚠ Do NOT tee the generator fuel supply line into the vehicle engine fuel supply line. If this is done, the generator will be starved of fuel when both engines are operating at the same time. Also, while the vehicle engine is not running, generator operation may drain the vehicle engine supply line, making it difficult to start the vehicle engine.

2.4.2 GENERATOR FUEL SUPPLY LINE

2.4.2.1 Rigid Fuel Lines

Those lines used to supply fuel from a tank to the generator must comply with applicable codes, standards and regulations. The following general rules apply to rigid fuel lines:

- Rigid lines should be of annealed, seamless, drawn aluminum or steel.
- Lines and fittings must comply with SAE J512F, "Standard Automotive Fittings," or with ANSI B126.26 (latest edition).
- Route the fuel line so that at least 2 inches (51 mm) of clearance is maintained between the line and any exhaust system parts.
- Do not attach electrical wiring to fuel lines. Route the wiring so it cannot come into contact with any fuel line.
- Route fuel lines so if they leak, fuel does not drip onto any electrical or exhaust system parts.
- Use nonferrous metal straps without sharp edges to secure fuel lines.

2.4.2.2 Flexible Fuel Line

Use an approved flexible length of fuel hose between the generator fuel inlet connection and rigid fuel lines. This prevents breaking of the line caused by vibration, shifting, settling or movement. The following rules apply:

- The flexible hose must comply with SAE J30R7, "Standard for Fuel and Oil Hose." It must be approved for use with gasoline and low permeability.
- The hose should be at least 6 inches (152 mm) longer than is needed to prevent the hose from rupturing if the generator shifts or settles.

2.5 EXHAUST SYSTEM

The generator exhaust system must be safely and properly installed. Only approved mufflers and other exhaust system parts must be used. A properly installed exhaust system must be vapor tight, quiet and completely safe.

⚠ DANGER!

⚠ The generator engine gives off DEADLY carbon monoxide gas through its exhaust system. This dangerous gas, if breathed in sufficient concentrations, can cause unconsciousness or even death. Never operate the generator set with the vehicle inside any garage or other enclosed area. DO NOT OPERATE THE GENERATOR IF THE EXHAUST SYSTEM IS LEAKING OR HAS BEEN DAMAGED. SYMPTOMS OF CARBON MONOXIDE POISONING ARE (a) inability to think coherently; (b) vomiting; (c) twitching muscles; (d) throbbing temples; (e) dizziness; (f) headaches; (g) weakness; and (h) sleepiness. IF FEELING ANY OF THESE SYMPTOMS, MOVE INTO FRESH AIR IMMEDIATELY. IF SYMPTOMS PERSIST, GET MEDICAL HELP. Do not operate the generator until its exhaust system has been inspected and properly repaired.

⚠ CAUTION!

⚠ Never tee the generator engine exhaust pipe into the vehicle engine exhaust piping. This causes excessive back pressure on the generator engine. Also, water from one engine can damage the other engine.

2.5.1 SPARK ARRESTOR

This spark arrestor assembly meets code and standard requirements of the U.S. Forest Service. Use only mufflers and parts approved by the manufacturer. Any person(s) installing an unapproved muffler, or an unapproved exhaust system part, or modifying an exhaust system in any way that might cause a hazard, is liable for any damage, injury or warranty expense that might be caused by such unapproved installation or modification.

Failure to provide and maintain a spark arrestor may be in violation of the law. If this generator is used on any forest covered, brush covered or grass covered unimproved land, provide a spark arrestor. The vehicle owner or operator must maintain this device in good condition. In the state of California, the preceding is required by law (Section 4442 of the California Public Resources Code). Other states may have similar laws. Federal laws apply on federal lands.

When installing/replacing the tailpipe or spark arrestor components, verify that the tailpipe has a hole to securely fasten the spark arrestor components (see Figures 2.11 and 2.12). Use only manufacturer supplied hardware. Substitution of parts may cause damage to the screen or a loose fit to the tailpipe.

Figure 2.11 - Spark Arrestor

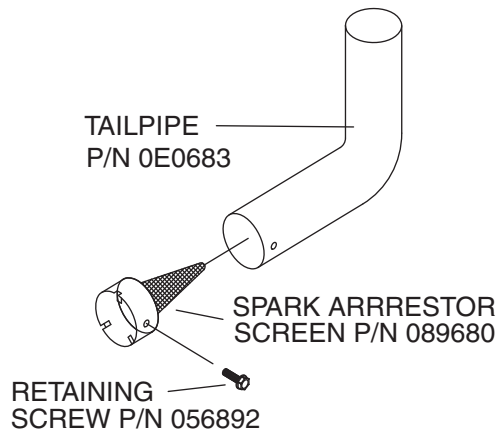
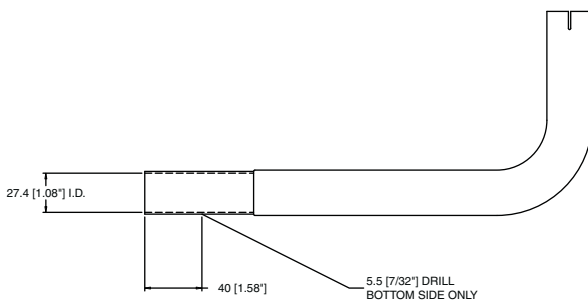

Figure 2.12 — Spark Arrestor Installation



2.5.2 EXHAUST SYSTEM SAFETY

- Maintain a clearance of at least 3 inches (76 mm) between exhaust system parts and any combustible material (such as wood, felt, cotton, organic fibers or other like material). If the 3-inch (76 mm) clearance cannot be maintained, locate, insulate or shield the exhaust part(s) so that the temperature of any combustible material is not raised more than 117° F (65° C) above the ambient air temperature.
- Extend the exhaust system at least 1 inch (25 mm) past the outer edge of the vehicle. Do not terminate the exhaust system under the vehicle.
- Terminate the exhaust tailpipe such that exhaust gases will not be drawn back into the generator compartment and recirculated.
- If there is any possibility of the tailpipe or muffler being damaged, protect these damage-prone areas by means of a protective device (such as a skid bar).
- Install the generator exhaust system according to safe automotive practices.
- Use enough exhaust system hangers to prevent any part of the system from being dislocated.
- Use exhaust system parts recommended by the manufacturer. Using unapproved exhaust mufflers and exhaust system parts is the responsibility of the person(s) installing such unauthorized parts.

- Do not terminate the exhaust system under any opening, window or vent that can be opened or is not permanently sealed from the vehicle interior.
- Exhaust piping must be large enough to prevent excessive back pressure on the generator engine.
- Never tee the generator engine exhaust pipe into the vehicle engine exhaust piping. This causes excessive back pressure on the generator engine. Also, water from one engine can damage the other engine.
- Plan exhaust system installation carefully. Comply with all applicable codes, standards and regulations.

2.6 ELECTRICAL CONNECTIONS

The following general rules apply to electrical connections in a recreational vehicle:

- Qualified electricians who are familiar with applicable codes, standards and regulations should install electrical wiring.
- The wiring should comply with codes, standards and regulations. The National Electrical Code (NFPA 70), and state and local codes apply.
- Switches and circuit breakers should be of a type approved for use in recreational vehicles and must be mounted and installed to prevent damage from road shock.
- Wiring must be of adequate size, have approved insulative qualities and be properly supported.
- Conduit and wire openings into the generator compartment (if used) must be vapor-sealed to prevent entry of flammable, explosive or poisonous gases into the vehicle.

2.6.1 ELECTRICAL JUNCTION BOX

Install an approved, square electrical junction box with a blank cover on the interior or exterior wall of the area planned for installation of the generator (NOT on the generator). Route the generator's AC output leads into this junction box through approved flexible conduit. This is the point of first termination for generator AC output leads.

2.6.2 WIRING

- Wiring should be of stranded copper to reduce the chance that vibration may cause breakage.
- Wire gauge size should be large enough to handle at least 115 percent of the installed generator's rated maximum current.
- Neutral conductors must be the same size as other leg wires.
- Route power supply conductors from generator AC output leads (white), (black) and the green ground wire through approved flexible conduit to the electrical junction box on the compartment wall.
- If flexible metal conduit is used between the generator and the compartment junction box, the conduit end that terminates the compartment junction box must be vapor-sealed. Flexible metal conduit is NOT vapor tight along its entire length.

- From the junction box, route power supply wires through approved conduit to either (a) double-pole, double-throw transfer switch, or (b) approved isolation receptacle. Connecting to a transfer switch or isolation receptacle must prevent vehicle electrical circuits from being connected to two different power supplies at the same time (such as generator and dockside power).
- Conductors must be rated 221° F (105° C) or must be of a larger conductor size.

2.6.3 GENERATOR AC CONNECTIONS

Generator AC output leads (BLACK) “hot” and (WHITE) grounded neutral come out of the generator as shown in Figure 2.13. There is also a green lead that connects to ground in the junction box of the recreational vehicle.

Leads BLACK to WHITE are protected against overload by a 30-amp circuit breaker (CB1). Use this line-to-neutral connection separately to operate 120-volt, single-phase, 60 Hertz, AC loads requiring up to 3,600 watts (3.6 kW) of power.

Figure 2.13 – Generator AC Output Leads

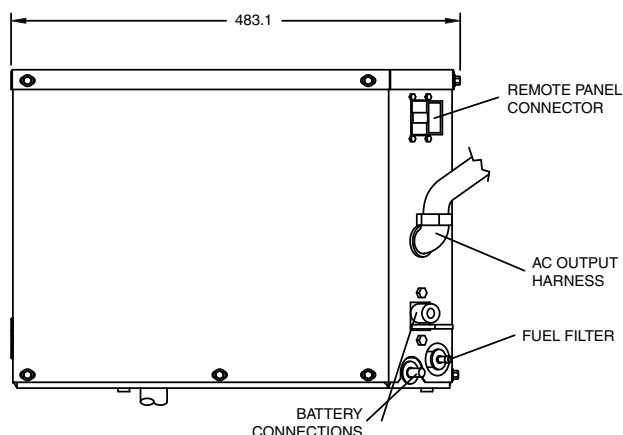

⚠ CAUTION!

Do NOT connect electrical loads in excess of any circuit breaker rating or problems will develop with circuit breaker tripping, which causes a loss of AC output. Also, do NOT exceed the generator's rated wattage capacity. Add the watts or amperes of all lighting, appliance, tool and motor loads the generator will operate at one time. This total should be less than the unit's rated wattage/ampere capacity.

2.6.4 CONDUIT

Route the connections between the generator and the junction box through approved, flexible conduit. The following general rules apply:

- Cut wiring to the required length and allow extra wire for junction box connections.
- Carefully prepare conduit ends to prevent sharp edges from cutting through wiring insulation.
- Route conduit so it does not interfere with generator movement.
- If using metallic conduit, vapor seal the end of the conduit where it enters the junction box. Do this because flexible metallic conduit is not vaporproof along its entire length.

2.6.5 ISOLATING DIFFERENT POWER SOURCES

Connections from the junction box must terminate in a double-pole, double-throw transfer switch (Figure 2.14). An alternate method for isolating different power sources is by using an isolating receptacle (Figure 2.15). Whichever method is used, be certain that both power sources are NOT connected at the same time.

2.6.6 POWER SUPPLY CORD

The power supply cord must comply with all applicable codes, standards and regulations. It must be large enough to handle the full amperage to which it will be subjected.

2.6.7 GROUND FAULT CIRCUIT INTERRUPTERS

The National Electrical Code (NFPA 70, 551-7) requires that ground fault circuit interrupters (GFCIs) be installed on all external and some internal electrical receptacles. Contact the dealer for recommendations.

2.7 BATTERY INSTALLATION

2.7.1 RECOMMENDED BATTERY

Install a battery that meets the following requirements:

- The battery must be a 12-volt, automotive type storage battery.
- For prevailing ambient temperatures above 32° F (0° C), use a battery rated 70 amp-hours and capable of delivering 400 cold-cranking amperes.
- For prevailing ambient temperatures below 32° F (0° C), use a battery rated 95 amp-hours and capable of delivering 400 cold-cranking amperes.

NOTE:

If the battery is to be used to power other vehicle accessories, as well as start the generator, a battery with a larger capacity may be needed.

Installation

Figure 2.14 – Transfer Switch Isolation Method

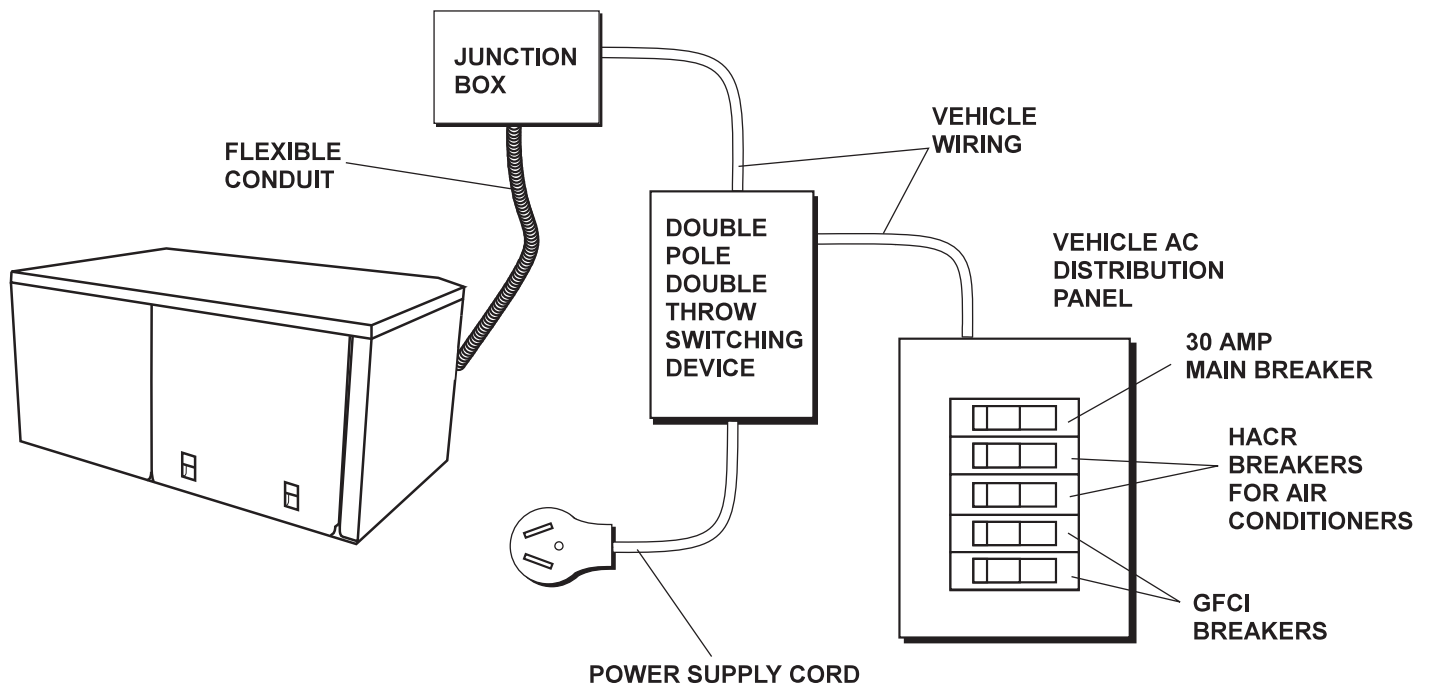
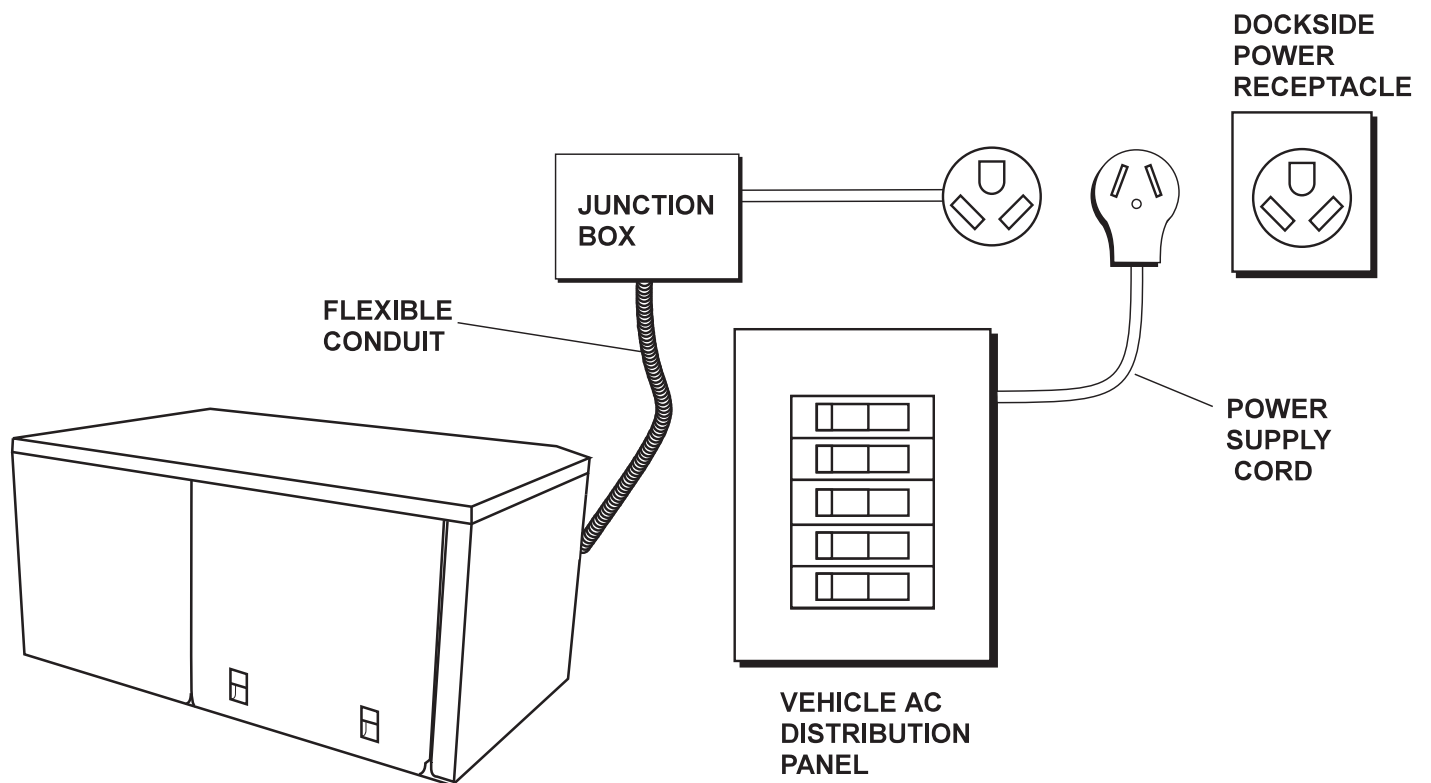

Figure 2.15 – Installation With Isolation Receptacle



2.7.2 BATTERY CABLES

Using battery cables that are too long or too small in diameter may cause a drop in voltage, which causes starting problems. For the best cold weather starting, the voltage drop between battery terminals and the generator connection point should not exceed 0.12 volts per 100 amperes of cranking current.

These generators are rated at about 100 DC amperes of cranking current.

Select battery cables based on (a) cable length and (b) prevailing ambient temperatures. Generally, the longer the cable and the colder the weather, the larger the cable size must be, as shown in the chart.

CABLE LENGTH in Feet (Meters)	CABLE SIZE
0 to 10 (0 to 3)	2*
11 to 15 (3.4 to 4.5)	0
16 to 20 (4.5 to 6)	000
* For warm weather, use No. 2 cable up to 20 feet.	

2.7.3 BATTERY CABLE CONNECTIONS

1. Connect the battery cable from the battery post or terminal indicated by a POSITIVE, POS or (+) to the lug on the starter contactor (Figure 2.16).

NOTE:

Check to be sure the battery cable boot for the starter cable has been installed.

2. Connect the battery cable from the battery post indicated by a NEGATIVE, NEG or (-) to the frame ground connection (Figure 2.16).
3. Connect cables so the connectors are clean and tight.

Figure 2.16 – Connecting Battery Cables

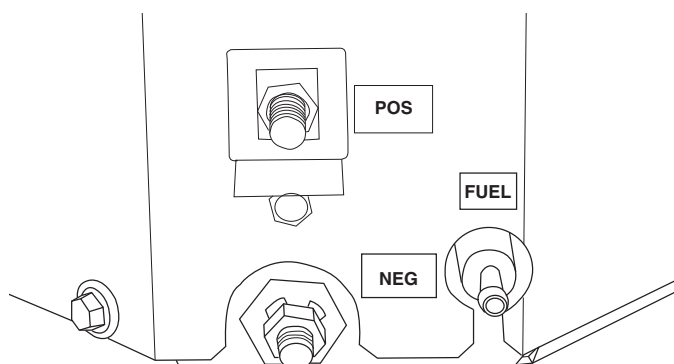

2.7.4 BATTERY COMPARTMENT

Install the generator battery in its own, vented compartment. Place the battery compartment away from any source of heat, sparks or flame.

Provide ventilation openings in the battery compartment. The minimum size of openings should be 2 square inches at the top of the compartment. Mount the battery on a strong, rigid supporting structure, where leaks and spills of battery fluid will not cause damage.

2.8 OPTIONAL ACCESSORIES

A plug-in receptacle (Figure 2.17) is provided on the generator set. Use this receptacle to connect an optional remote-mounted start/stop panel to the generator. Installation of such a panel will permit starting and stopping the generator engine from any convenient location inside the vehicle.

Figure 2.17 – Remote Panel Plug-in Receptacle

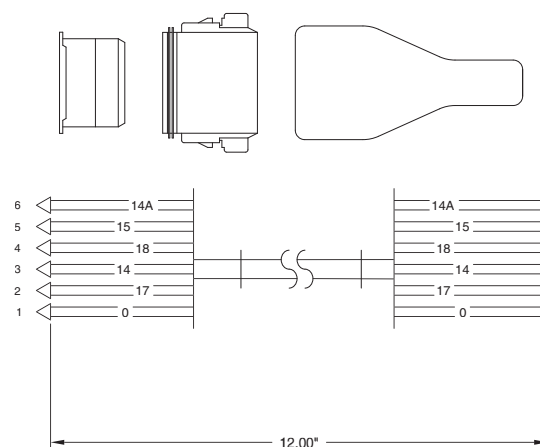

WIRE No.	WIRE COLOR	LENGTH (mm)	FUNCTION
0	WHITE	12.0 (305)	GROUND
14	RED	12.0 (305)	ENGINE RUN SIGNAL
15	ORANGE	12.0 (305)	12 VDC
17	YELLOW	12.0 (305)	START
18	BROWN	12.0 (305)	STOP
14A	BLUE	12.0 (305)	PRIME

P/N: 0D9099-B

2.8.1 REMOTE START/STOP PANEL

A remote mounted Start/Stop panel is available that allows the user to start and stop the generator engine conveniently from inside the vehicle. The remote panel includes a Start/Stop switch, hourmeter, generator run lamp, a fuel prime switch, and a wire harness. The hourmeter should be used in conjunction with the maintenance operations found in Part I of this manual.

Post Installation Start-up Adjustments

3.1 POST INSTALLATION TESTS

The air-cooled generator set was factory tested and adjusted. It should not be required to adjust the unit any further except under special circumstances.

⚠ WARNING!

⚠ Do not make any unnecessary adjustments. Factory settings are correct for most applications. When making adjustments, however, be careful to avoid overspeeding the engine.

3.2 BEFORE INITIAL START-UP

Before starting, complete the following:

1. Check the engine crankcase oil level and, if necessary, fill to the dipstick "FULL" mark (cross-hatched area) with the recommended oil. Do not fill above the FULL mark.
2. Check the fuel supply. Gas fuel lines must have been properly purged and leak tested in accordance with applicable fuel codes. All fuel shutoff valves in the fuel supply lines must be open.

⚠ DANGER!

⚠ If a liquid propane (LP) gas fuel system has been installed, it must be properly tested for leaks before operating the system in compliance with ANSI A119.2/NFPA 501C. No leakage is permitted. Be sure that no gasoline fuel vapors enter the vehicle interior.

3.3 INITIAL START

When absolutely certain that the unit has been properly installed and prepared for use, start the engine as follows:

1. Turn off all electrical loads. Do this by setting the generator's main circuit breakers to their "OFF" (or OPEN) position.
2. Refer to Part I, "Starting the Generator", for cranking and starting instructions. The engine may require more cranking for initial starting since the fuel lines have to be primed (use of the primer switch will shorten this time).

3. Let the engine warm up for about five minutes to allow internal temperatures to stabilize.
4. Carefully inspect the engine/generator for fuel, oil and exhaust system leaks. Before proceeding to the next step, correct any leakage immediately.
5. When all tests and adjustments at no-load are completed, apply electrical loads and check for proper operation under load (see "Testing Under Load"). Run the unit at least 30 minutes with loads applied.
6. Turn off all electrical loads by setting the generator's main circuit breakers to their "OFF" (or OPEN) position.
7. Let the unit run at no-load for a few minutes to stabilize internal engine/generator temperatures. Then, shut down the engine.

NOTE:

The generator set was thoroughly tested and adjusted at the factory before shipping. No additional adjustment should be necessary. Only qualified service technicians who have been trained should perform adjustments outlined in this manual.

3.4 TESTING UNDER LOAD

Apply electrical loads equal to about 75 to 100 percent of the unit's rated wattage/ampere capacity.

Let the unit run at least 30 minutes with load applied. During this part of the test, check that the unit is not running excessively hot and that adequate cooling airflow is available. Do not allow the unit to overheat during prolonged operation.

NOTE:

The generator engine is equipped with a high temperature switch. The switch has normally closed (N.C.) contacts. When the engine temperature is too high, switch contacts close, and the engine shuts down automatically.

THE MANUFACTURER RECOMMENDS THAT THE GENERATOR BE TESTED FOR ADEQUATE COOLING.

3.5 INSTALLATION CHECKLIST

LOCATION AND SUPPORT

- Generator is properly located.
- Generator is properly supported.
- Generator is properly restrained.

GENERATOR COMPARTMENT

- Compartment construction is proper.
- Holes/Openings are vapor-sealed.
- Compartment size is correct.
- Compartment is vapor-sealed.
- Sound insulation is correct.
- Floor cutouts are properly completed.

COOLING AND VENTILATING AIR

- Airflow is adequate.
- Air inlet opening is correct.
- Compensate for restrictions.
- Check that installation has been tested.

GASOLINE FUEL SYSTEM

- Fuel tank complies with all applicable codes.
- Fuel system is properly installed and checked for leaks.

OPTIONAL LP GAS FUEL SYSTEM

- Fuel system is properly installed and checked for leaks.
- Pressure at regulator inlet is correct.
- Rated flow of primary regulator is correct.
- All parts are properly installed.
- Fuel system is properly tested/adjusted.

EXHAUST SYSTEM

- Exhaust system complies with all applicable codes.
- Exhaust system is properly and safely installed.

ELECTRICAL CONNECTIONS

- Connections comply with local code requirements and all National Electrical Codes.
- Junction box is properly installed.
- Wiring meets all standards.
- All connections are correct.
- Conduit is properly installed and sealed.
- Generator is properly bonded to the vehicle.

BATTERY INSTALLATION

- Recommended battery is installed.
- Recommended cables are installed.
- Cables are clean and tight.
- Cables are connected properly.
- Proper ventilation is provided.
- Terminals are coated with anti-corrosion grease, and terminal covers are positioned.

OPTIONAL ACCESSORIES

- Check that remote start/stop panels (if used) are installed properly.
- Check that hourmeter kit (if used) is installed properly.
- Check that any other options and accessories (if used) are installed properly.

POST INSTALLATION TESTS

- Check that all tests are completed properly.

DATE OF INSTALLATION _____

NAME OF INSTALLER _____

SIGNATURE OF INSTALLER _____

TROUBLESHOOTING GUIDE

Problem	Cause	Correction
The engine will not crank.	<ol style="list-style-type: none"> 1. Fuse blown. 2. Loose, corroded or defective battery cables. 3. Defective engine Start/Stop switch. 4. Defective starter contactor. 5. Defective starter motor. 6. Low or defective battery. 	<ol style="list-style-type: none"> 1. Replace fuse. 2. Tighten, clean or replace as necessary. 3. Replace Start/Stop switch. 4. Replace contactor. 5. Replace starter motor. 6. Charge or replace battery.
The engine cranks but will not start.	<ol style="list-style-type: none"> 1. Out of fuel. 2. Defective fuel pump. 3. Open #14 wire from engine control board. 4. Flooded engine. 5. Defective spark plug(s). 6. Fuel line shut-off closed. 7. Plugged fuel filter. 	<ol style="list-style-type: none"> 1. Replenish fuel. 2. Replace fuel pump. 3. Check connections and insulation of #14 wires. 4. Wait 5-10 minutes before trying. 5. Clean, re-gap or replace plug(s). 6. Open fuel line shut-off. 7. Clean or replace fuel filter.
The engine starts hard and runs rough.	<ol style="list-style-type: none"> 1. Air cleaner plugged or damaged. 2. Defective spark plug(s). 	<ol style="list-style-type: none"> 1. Check, clean or replace air cleaner. 2. Clean, re-gap or replace plug(s).
The engine starts, but shuts down when the Start/Stop switch is released.	<ol style="list-style-type: none"> 1. Engine oil level low. 2. Defective low oil pressure switch. 3. Defective high temperature switch. 4. Defective engine control board. 5. Overheated engine. 	<ol style="list-style-type: none"> 1. Check oil and add oil as needed. 2. Replace pressure switch. 3. Replace temperature switch. 4. Replace control board. 5. Check that the airflow openings are adequate.
The Start/Stop switch is set to Stop, but the engine continues to run.	<ol style="list-style-type: none"> 1. Defective Start/Stop switch. 2. Open/Disconnected #18 wire between Start/Stop switch and engine control board. 3. Open/Disconnected #0 wire between Start/Stop switch and engine control board. 4. Defective engine control board. 	<ol style="list-style-type: none"> 1. Replace switch. 2. Reconnect or close wire. 3. Reconnect or close wire. 4. Replace control board.
There is no AC output from the generator.	<ol style="list-style-type: none"> 1. Main line circuit breaker open. 2. Fault with vehicle circuit breaker and/or fuses. 3. Transfer switch set to NORMAL. 4. Start switch not held long enough to flash the field. 5. Generator internal failure. 	<ol style="list-style-type: none"> 1. Reset circuit breaker to ON (or closed). 2. Reset and replace if necessary. 3. Set switch to GENERATOR. 4. Stop, then restart the engine (Hold Start switch for at least two (2) seconds). 5. Contact aN Authorized Service Dealer.

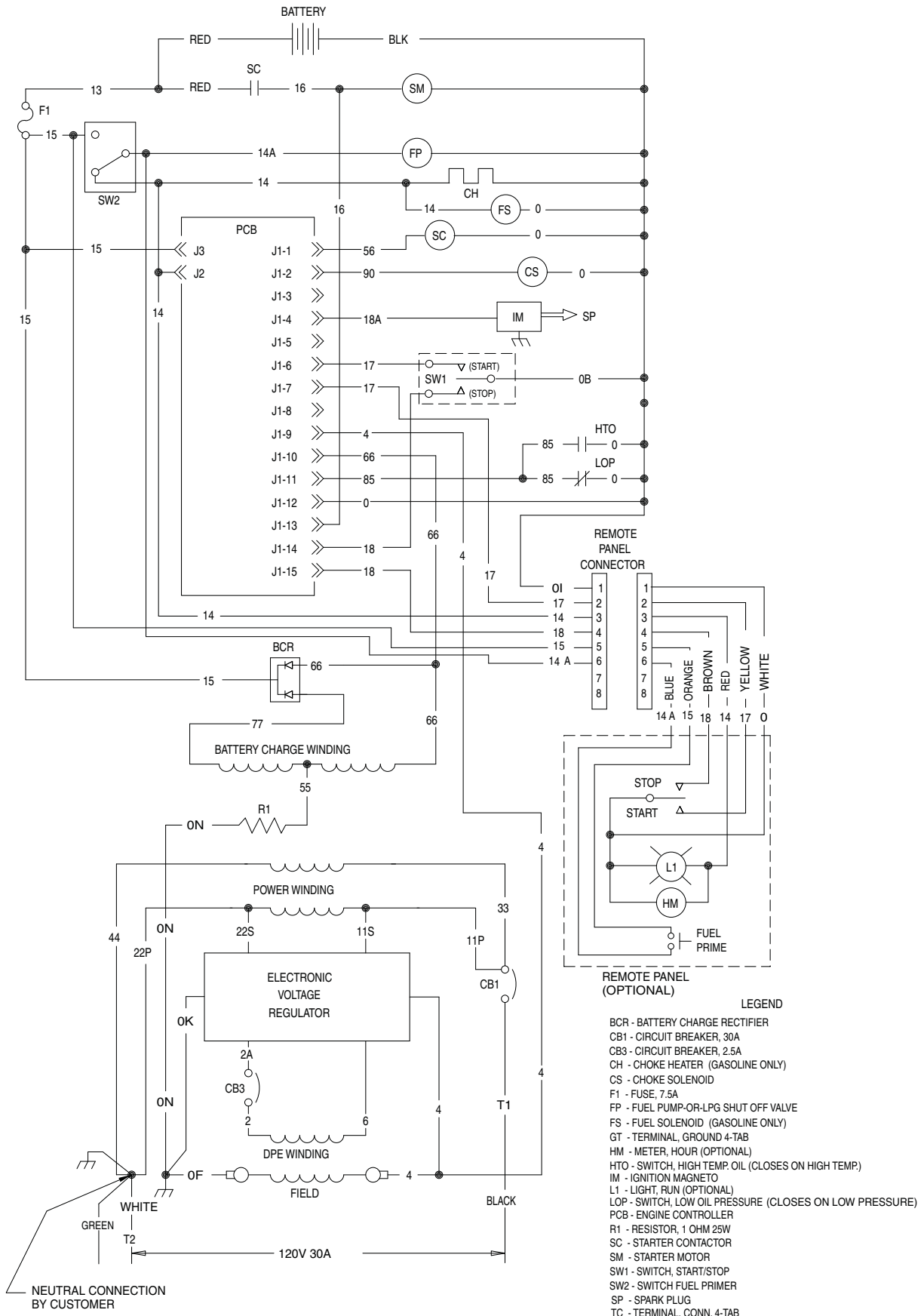

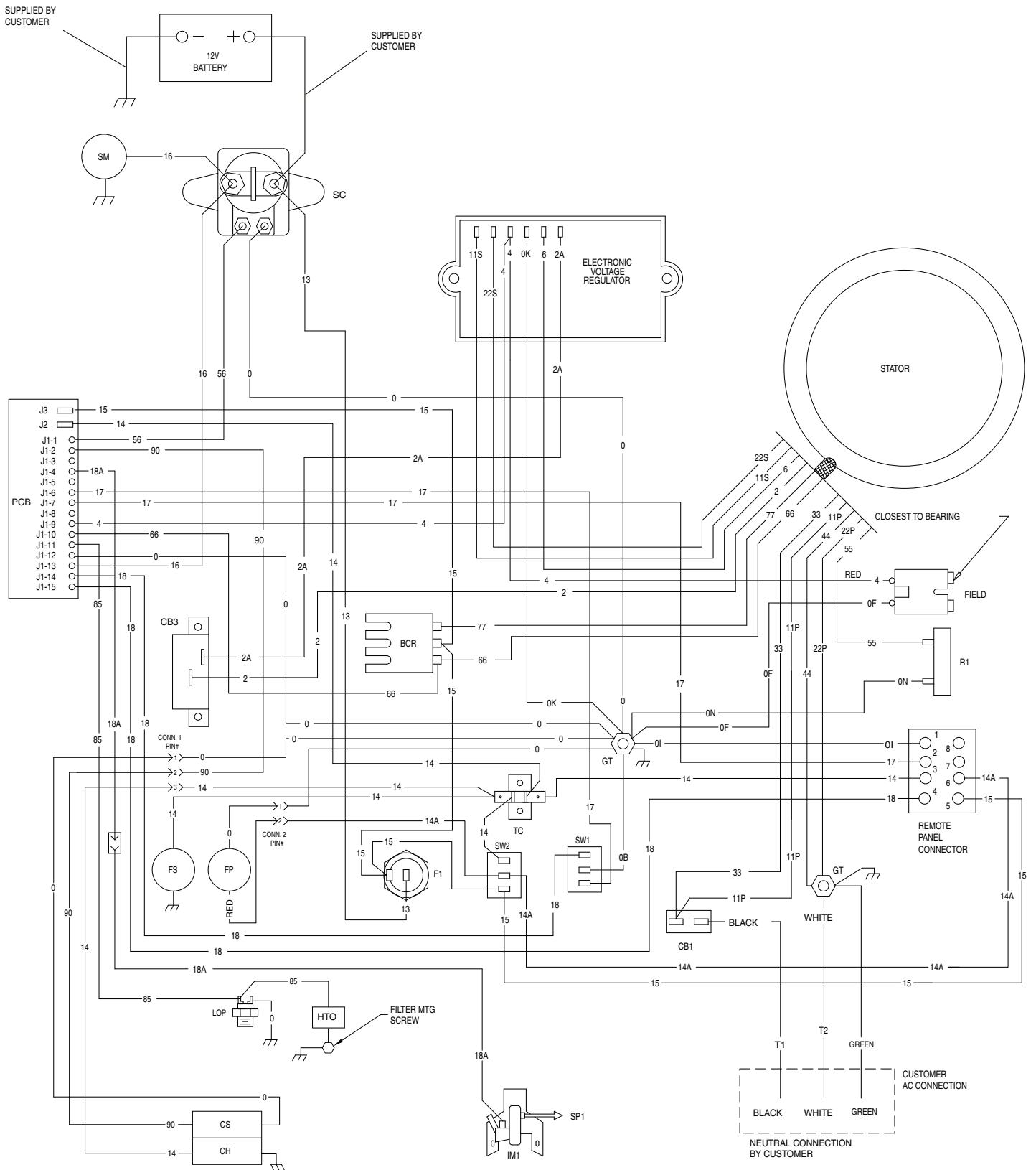

Warranty

CALIFORNIA AND U.S. EPA EXHAUST EMISSION CONTROL WARRANTY STATEMENT YOUR WARRANTY RIGHTS AND OBLIGATIONS

The California Air Resource Board (CARB) and the United States Environmental Protection Agency (EPA), together with Generac Power Systems, Inc. (Generac) are pleased to explain the Emission Control System Warranty (ECS Warranty) on your new 2012 equipment. New equipment that use small spark-ignited engines must be designed, built, and equipped to meet stringent anti-smog standards for the state of California and the federal government. Generac will warrant the exhaust emission control system on your equipment for the period of time listed below provided there has been no abuse, neglect, unapproved modification or improper maintenance of your equipment.

The exhaust emission control system on this equipment includes all components whose failure would increase the exhaust emissions of any regulated pollutant. These components are listed in the Emissions Information section of this manual.

MANUFACTURER'S WARRANTY COVERAGE:

This ECS Warranty is valid for two years, or for the same period as specified in the Generac Limited Warranty, whichever is longer. For equipment with hour meters, the warranty period is a number of hours equal to half the Useful Life to which the equipment is certified, or the warranty period specified above in years, whichever is less. The Useful Life can be found on the Emission Control Label on the engine. If, during such warranty period, any emission-related part on your equipment is found to be defective in materials or workmanship, repairs or replacement will be performed by a Generac Authorized Warranty Service Dealer.

OWNER'S WARRANTY RESPONSIBILITIES:

As the equipment owner, you are responsible for the completion of all required maintenance as listed in your factory supplied Owner's Manual. For warranty purposes, Generac recommends that you retain all receipts covering maintenance on your generator, but Generac cannot deny warranty solely due to the lack of receipts.

You should be aware that Generac may deny any and/or all warranty coverage or responsibility if your equipment, or a part/component thereof, has failed due to abuse, neglect, improper maintenance, or unapproved modifications.

You are responsible for contacting a Generac Authorized Warranty Dealer as soon as a problem occurs. The warranty repairs should be completed in a reasonable amount of time, not to exceed 30 days.

Warranty service can be arranged by contacting either your selling dealer or a Generac Authorized Warranty Service Dealer. To locate the Generac Authorized Warranty Service Dealer nearest you, call our toll free number below, or email emissions@generac.com.

1-800-333-1322

IMPORTANT NOTE: This warranty statement explains your rights and obligations under the Emission Control System Warranty, which is provided to you by Generac pursuant to federal law. See also the "Generac Limited Warranties for Generac Power Systems, Inc.," which is enclosed herewith on a separate sheet, also provided to you by Generac. Note that this warranty shall not apply to any incidental, consequential or indirect damages caused by defects in materials or workmanship or any delay in repair or replacement of the defective part(s). This warranty is in place of all other warranties, expressed or implied. Specifically, Generac makes no other warranties as to the merchantability or fitness for a particular purpose. Any implied warranties allowed by law shall be limited in duration to the terms of the express warranty provided herein. Some states do not allow limitations on how long an implied warranty lasts, so the above limitation may not apply to you.

The ECS Warranty applies only to the emission control system of your new equipment. Both the ECS Warranty and the Generac Warranty describe important rights and obligations with respect to your new engine.

Warranty service can be performed only by a Generac Authorized Warranty Service Facility. When requesting warranty service, evidence must be presented showing the date of the sale to the original purchaser/owner.

If you have any questions regarding your warranty rights and responsibilities, you should contact Generac at the following address:

**ATTENTION WARRANTY DEPARTMENT
GENERAC POWER SYSTEMS, INC.
P.O. BOX 297 • WHITEWATER, WI 53190**

Warranty

EXHAUST EMISSION CONTROL SYSTEM WARRANTY

Exhaust Emission Control System Warranty (ECS Warranty) for equipment using small spark-ignited engines:

- (a) Applicability: This warranty shall apply to equipment that uses small off-road engines. The ECS Warranty period shall begin on the date the new equipment is purchased by/delivered to its original, end-use purchaser/owner and shall continue for the lesser of:
 - (1) The period of time specified in the Generac Limited Warranty enclosed herewith, but not less than 24 months, or
 - (2) For engines equipped with hour meters, a number of operating hours equal to half of the engine's useful life. The useful life is specified on the Emissions Control Label on the engine.
- (b) General Emissions Warranty Coverage: Generac warrants to the original, end-use purchaser/owner of the new engine or equipment and to each subsequent purchaser/owner that the ECS when installed was:
 - (1) Designed, built and equipped so as to conform with all applicable regulations; and
 - (2) Free from defects in materials and workmanship which cause the failure of a warranted part at any time during the ECS Warranty Period.
- (c) The warranty on emissions-related parts will be interpreted as follows:
 - (1) Any warranted part that is not scheduled for replacement as required maintenance in the Owner's Manual shall be warranted for the ECS Warranty Period. If any such part fails during the ECS Warranty Period, it shall be repaired or replaced by Generac according to Subsection (4) below. Any such part repaired or replaced under the ECS Warranty shall be warranted for the remainder of the ECS Warranty Period.
 - (2) Any warranted part that is scheduled only for regular inspection as specified in the Owner's Manual shall be warranted for the ECS Warranty Period. A statement in the Owner's Manual to the effect of "repair or replace as necessary" shall not reduce the ECS Warranty Period. Any such part repaired or replaced under the ECS Warranty shall be warranted for the remainder of the ECS Warranty Period.
 - (3) Any warranted part that is scheduled for replacement as required maintenance in the Owner's Manual shall be warranted for the period of time prior to first scheduled replacement point for that part. If the part fails prior to the first scheduled replacement, the part shall be repaired or replaced by Generac according to Subsection (4) below. Any such emissions-related part repaired or replaced under the ECS warranty shall be warranted for the remainder of the period prior to the first scheduled replacement point for that part.
 - (4) Repair or replacement of any warranted, emissions-related part under this ECS Warranty shall be performed at no charge to the owner at a Generac Authorized Warranty Service Facility.
 - (5) Notwithstanding the provisions of subsection (4) above, warranty services or repairs must be provided at Generac Authorized Service Facilities.
 - (6) When the engine is inspected by a Generac Authorized Warranty Service Facility, the purchaser/owner shall not be held responsible for diagnostic costs if the repair is deemed warrantable.
 - (7) Throughout the ECS Warranty Period, Generac shall maintain a supply of warranted emission-related parts sufficient to meet the expected demand for such parts.
 - (8) Any Generac authorized and approved emission-related replacement parts may be used in the performance of any ECS Warranty maintenance or repairs and will be provided without charge to the purchaser/owner. Such use shall not reduce Generac ECS Warranty obligations.
 - (9) No modifications, other than those explicitly approved by Generac, may be made to the generator. Unapproved modifications void this ECS Warranty and shall be sufficient ground for disallowing an ECS Warranty claim.
 - (10) Generac shall not be held liable hereunder for failures of any non-authorized replacement parts, or failures of any authorized parts caused by the use of non-authorized replacement parts.

EXHAUST EMISSION RELATED PARTS MAY INCLUDE THE FOLLOWING (IF EQUIPPED):

- | | |
|----------------------------------|----------------------------|
| 1) FUEL METERING SYSTEM | 3) IGNITION SYSTEM |
| A. CARBURETOR AND INTERNAL PARTS | A. SPARK PLUGS |
| B. REGULATOR (GASEOUS FUELS) | B. IGNITION COILS / MODULE |
| 2) AIR INDUCTION SYSTEM | 4) AIR INJECTION SYSTEM |
| A. INTAKE MANIFOLD | A. PULSE AIR VALVE |
| B. AIR FILTER | 5) EXHAUST SYSTEM |
| | A. CATALYST |
| | B. EXHAUST MANIFOLD |

Warranty

GENERAC POWER SYSTEMS' THREE-YEAR LIMITED WARRANTY FOR RECREATIONAL VEHICLE GENERATORS

NOTE: ALL UNITS MUST BE INSTALLED BY GENERAC POWER SYSTEMS AUTHORIZED SERVICE FACILITIES.

For a period of 3 (three) years of operation from the date of original sale or 1,000 hours, whichever occurs first, Generac Power Systems, Inc. (Generac) will, at its discretion, repair or replace any part that, upon examination, inspection and testing by Generac or a Generac Authorized Warranty Service Facility, is found to be defective under normal use and service, in accordance with the warranty schedule set forth below. Any equipment that the purchaser/owner claims to be defective must be returned to and examined by the nearest Generac Authorized Warranty Service Facility. All transportation costs under the warranty, including return to the factory, are to be borne and prepaid by the purchaser/owner. This warranty applies only to Generac generators sold and rated for "Recreational Vehicle" (RV) applications, as Generac has defined Recreational Vehicle generator applications. The factory recommends exercising the unit one half-hour every month.

WARRANTY SCHEDULE – COMMERCIAL APPLICATIONS

YEAR ONE – Limited comprehensive coverage on part(s), labor, removal and reinstallation listed:

- **Engine** – All components
- **Alternator** – All components

WARRANTY SCHEDULE – CONSUMER/PERSONAL APPLICATIONS

YEARS ONE AND TWO – Limited comprehensive coverage on part(s), labor, removal and reinstallation listed:

- **Engine** – All components
- **Alternator** – All components

YEAR THREE – Limited comprehensive only on selected part(s) and labor listed [Any labor and part(s) not listed, and removal and reinstallation are the owner's responsibility]:

- Rotor, Stator, Computer Control Board, Cylinder Block, Cylinder Head, Crankshaft, Piston(s), Valve, Valve Lifter(s), Intake and Exhaust Manifolds.

Extended Warranties are not available on units sold into International Markets.

Generac RV generators have a transferable warranty to the second owner **ONLY** for the remainder of the three-year limited warranty. Proof-of-purchase is required and must be presented to a Generac Authorized Warranty Service Facility prior to the performance of any warranty service.

All warranty expense allowances are subject to the conditions defined in Generac's Warranty Policies and Procedures Guide.

THIS WARRANTY SHALL NOT APPLY TO THE FOLLOWING:

- Generac generators that utilize non-Generac replacement parts.
- Costs of normal maintenance, adjustments, installation and start-up.
- Repairs or diagnostics performed by individuals other than Generac authorized dealers not authorized in writing by Generac Power Systems.
- Failures caused by any contaminated fuels, oils, coolants or lack of proper fluid amounts.
- Failures due, but not limited, to normal wear and tear, accident, misuse, abuse, negligence or improper installation and/or maintenance. As with all mechanical devices, the Generac engines need periodic part(s) service and replacement to perform well. This warranty will not cover repair when normal use has exhausted the life of a part(s) or engine.
- Failures caused by any external cause or act of God, such as collision, theft, vandalism, riot or wars, nuclear holocaust, fire, freezing, lightning, earthquake, windstorm, hail, volcanic eruption, water or flood, tornado or hurricane.
- Damage related to rodent and/or insect infestation.
- Products that are modified or altered in a manner not authorized by Generac in writing.
- Any incidental, consequential or indirect damages caused by defects in materials or workmanship, or any delay in repair or replacement of the defective part(s).
- Failure due to misapplication.
- Telephone, cellular phone, facsimile, internet access or other communication expenses.
- Living or travel expenses of person(s) performing service, except as specifically included within the terms of a specific unit warranty period.
- Expenses related to "customer instruction" or troubleshooting where no manufacturing defect is found.
- Rental equipment used while warranty repairs are being performed.
- Overnight freight costs for replacement part(s).
- Overtime labor.
- Starting batteries, fuses, light bulbs and engine fluids.

THIS WARRANTY IS IN PLACE OF ALL OTHER WARRANTIES, EXPRESSED OR IMPLIED. SPECIFICALLY, GENERAC MAKES NO OTHER WARRANTIES AS TO THE MERCHANTABILITY OR FITNESS FOR A PARTICULAR PURPOSE. Any implied warranties which are allowed by law, shall be limited in duration of the terms of the express warranty provided herein. Some states do not allow limitations on how long an implied warranty lasts, so the above limitation may not apply to you.

GENERAC'S ONLY LIABILITY SHALL BE THE REPAIR OR REPLACEMENT OF PART(S) AS STATED ABOVE. IN NO EVENT SHALL GENERAC BE LIABLE FOR ANY INCIDENTAL OR CONSEQUENTIAL DAMAGES, EVEN IF SUCH DAMAGES ARE A DIRECT RESULT OF GENERAC'S NEGLIGENCE. Some states do not allow the exclusion or limitation of incidental or consequential damages, so the above limitation may not apply to you. This warranty gives you specific legal rights. You also have other rights from state to state.

GENERAC® POWER SYSTEMS, INC. • P.O. BOX 297 • WHITEWATER, WI 53190

Part No. 0H8812

Rev. C 02/12

Part No. 0D8351

Revision Ab (03/07/12)