



Owner's Manual
Automatic Transfer Switch

*150 - 200 Amp, Integrated Meter Transfer Switch, Service Entrance
Rated*

Register your Generac product at:
WWW.REGISTER.GENERAC.COM
1-888-9ACTIVATE
(1-888-922-8482)

SAVE THIS MANUAL FOR FUTURE REFERENCE

| | |
|-----------------|--|
| Model: | |
| Serial: | |
| Date Purchased: | |

Model Number

Integrated Ringed Meter Transfer Switch

RXUW200A3 – 200A

RXUW150A3 – 150A

Upgradeable Integrated Ringless Meter Transfer Switch

RBU200A3 – 200A

RBU150A3 – 150A

G0074000 – RBU Transfer Switch Upgrade Kit

*10000011659 - Assembly Number for RSXW200A3
When Bundled with Generator

| |
|---|
|  <p>WARNING CANCER AND REPRODUCTIVE HARM www.p65warnings.ca.gov</p> <p style="text-align: right;">(W000393)</p> |
|---|

Table of Contents

Section 1: Safety

| | |
|-----------------------------------|----------|
| Introduction | 5 |
| Read This Manual Thoroughly | 5 |
| Safety Rules | 5 |
| Electrical Hazards | 6 |
| General Hazards | 7 |

Section 2: General Information

| | |
|--|-----------|
| Introduction | 9 |
| Unpacking | 9 |
| Contents in Loose Parts Bag | 9 |
| Equipment Description | 9 |
| Transfer Switch Mechanism (RXUW Models or RBU with Upgrade Kit (G007400) Installed) | 9 |
| Utility Service Circuit Breaker | 10 |
| Transfer Switch Data Decal | 10 |
| Transfer Switch Enclosure | 10 |
| Safe Use of Transfer Switch | 10 |
| Load Management Options | 10 |
| Accessories | 11 |
| Smart A/C Module (SACM) | 11 |
| Smart Management Module (SMM) (sold separately) | 12 |
| Application Considerations | 12 |

Section 3: Installation

| | |
|--|-----------|
| Introduction to Installation | 13 |
| Mounting | 13 |
| Open Enclosure | 13 |
| Connecting Power Source (RBU and RXUW) | 14 |
| Connecting Alternate Power Source (RXUW Only) | 15 |
| Connecting Start Circuit Wires | 16 |
| Typical SACM Connections | 17 |
| Connecting SACM | 17 |
| Control of Air Conditioner Load | 17 |
| Auxiliary Contact | 17 |
| Fault Current Label | 18 |
| Install Upgrade Kit G0074000 (RBU Only) | 19 |

Section 4: Operation (RXUW Models and Up- graded RBU)

| | |
|--|-----------|
| Functional Tests and Adjustments | 21 |
| Manual Operation | 21 |
| Close to Utility Source Side | 21 |
| Close to Generator Source Side | 21 |
| Return to Utility Source Side | 22 |
| Voltage Checks | 22 |
| Generator Voltage Checks | 22 |
| Utility Voltage Checks | 22 |
| Generator Tests Under Load | 22 |
| Checking Automatic Operation | 23 |
| Installation Summary | 23 |
| Shutting Generator Down While Under Load or During a Utility Outage | 23 |
| Preparing for Maintenance | 24 |
| Testing the SACM | 24 |
| SACM Fuse Service | 24 |

Section 5: Drawings and Diagrams

| | |
|---|-----------|
| Installation Drawings—150-200A SER Meter Main | 25 |
| Interconnection Drawings—Liquid-Cooled Generator | 26 |
| Interconnection Drawings—Liquid-Cooled Generator | 27 |
| Accessory KIT 200A XFRSW W SACM G0074000 | 28 |
| Accessory Kit ATS Ring Cover G0074010 | 29 |
| Accessory Kit Meter Jaw 5th Terminal G0074020 | 30 |
| Accessory Kit Flash Shield G0074040 | 31 |
| Accessory Kit Side Bus G0074050 | 32 |
| Accessory Kit Pedestal 24 in. Extension G0074060 | 33 |
| Accessory Kit Pedestal 48 in. Extension G0074070 | 34 |
| Accessory Kit ATS Ringless Cover G0074080 | 35 |
| Accessory Kit Tamper Proof Upper Cover G0074100 | 36 |

Accessory Kit Utility Barrel Lock
G0074130..... 37

Section 1: Safety

Introduction

Thank you for purchasing a Generac Power Systems Inc. product. This unit has been designed to provide high performance, efficient operation, and years of use when maintained properly.

NOTE: Before selecting this switch, verify that it is local Utility Service Provider approved. Visit www.generac.com/integrated-meter-approval to view list of utility service providers by state.

Read This Manual Thoroughly



Consult Manual. Read and understand manual completely before using product. Failure to completely understand manual and product could result in death or serious injury.

(W000100)

If any section of this manual is not understood, contact the nearest Independent Authorized Service Dealer (IASD) or Generac Customer Service at 1-888-436-3722 (1-888-GENERAC), or visit www.generac.com for starting, operating, and servicing procedures. The owner is responsible for proper maintenance and safe use of the unit.

SAVE THESE INSTRUCTIONS for future reference. This manual contains important instructions that must be followed during placement, operation, and maintenance of the unit and its components. Always supply this manual to any individual that will use this unit, and instruct them on how to correctly start, operate, and stop the unit in case of emergency.

Safety Rules

The manufacturer cannot anticipate every possible circumstance that might involve a hazard. The alerts in this manual, and on tags and decals affixed to the unit, are not all inclusive. If using a procedure, work method, or operating technique that the manufacturer does not specifically recommend, verify that it is safe for others and does not render the equipment unsafe.

Throughout this publication, and on tags and decals affixed to the unit, DANGER, WARNING, CAUTION, and NOTE blocks are used to alert personnel to special instructions about a particular operation that may be hazardous if performed incorrectly or carelessly. Observe them carefully. Alert definitions are as follows:



Indicates a hazardous situation which, if not avoided, will result in death or serious injury.

(D000001)



Indicates a hazardous situation which, if not avoided, could result in death or serious injury.

(W000002)



Indicates a hazardous situation which, if not avoided, could result in minor or moderate injury.

(C000003)

NOTE: Notes contain additional information important to a procedure and will be found within the regular text of this manual.

These safety alerts cannot eliminate the hazards that they indicate. Common sense and strict compliance with the special instructions while performing the action or service are essential to preventing accidents.

Electrical Hazards



⚠ DANGER

Electrocution. High voltage is present at transfer switch and terminals. Contact with live terminals will result in death or serious injury.

(D000129)



⚠ DANGER

Electrocution. Water contact with a power source, if not avoided, will result in death or serious injury.

(D000104)



⚠ DANGER

Electrocution. In the event of electrical accident, immediately shut power OFF. Use non-conductive implements to free victim from live conductor. Apply first aid and get medical help. Failure to do so will result in death or serious injury.

(D000145)



⚠ DANGER

Electrical backfeed. Use only approved switchgear to isolate generator from the normal power source. Failure to do so will result in death, serious injury, and equipment damage.

(D000237)



⚠ DANGER

Electrocution, equipment and property damage. Handle transfer switches carefully when installing. Never install a damaged transfer switch. Doing so could result in death or serious injury, equipment and property damage.

(D000195)



⚠ DANGER

Electrocution. Turn utility supply OFF before working on utility connections of the transfer switch. Failure to do so will result in death or serious injury.

(D000123)



⚠ DANGER

Electrocution. Do not disable or modify the connection box door safety switch. Doing so will result in death or serious injury.

(D000157)

⚠ DANGER

Automatic start-up. Disconnect utility power and render unit inoperable before working on unit. Failure to do so will result in death or serious injury.

(D000191)

⚠ DANGER

Equipment Malfunction. Installing a dirty or damaged transfer switch will cause equipment malfunction and will result in death or serious injury.

(D000119)

⚠ WARNING

Electric Shock. Only a trained and licensed electrician should perform wiring and connections to unit. Failure to follow proper installation requirements could result in death, serious injury, and equipment or property damage.

(W000155)

⚠ CAUTION

Equipment damage. Verify all conductors are tightened to the factory specified torque value. Failure to do so could result in damage to the switch base.

(C000120)

⚠ CAUTION

Equipment damage. Perform functional tests in the exact order they are presented in the manual. Failure to do so could result in equipment damage.

(C000121)

⚠ CAUTION

Equipment damage. Verify that voltage and current are within specification before energizing this equipment. Exceeding rated voltage and current will damage the auxiliary contacts.

(C000134)

General Hazards



⚠ DANGER

Electrical backfeed. Use only approved switchgear to isolate generator from the normal power source. Failure to do so will result in death, serious injury, and equipment damage.

(D000237)



⚠ DANGER

Electrocution. High voltage is present at transfer switch and terminals. Contact with live terminals will result in death or serious injury.

(D000129)



⚠ DANGER

Electrocution. Turn utility supply OFF before working on utility connections of the transfer switch. Failure to do so will result in death or serious injury.

(D000123)



⚠ DANGER

Electrocution. Water contact with a power source, if not avoided, will result in death or serious injury.

(D000104)



⚠ DANGER

Electrocution. Do not wear jewelry while working on this equipment. Doing so will result in death or serious injury.

(D000188)



⚠ DANGER

Electrocution. Only authorized personnel should access transfer switch interior. Transfer switch doors should be kept closed and locked. Failure to do so will result in death or serious injury.

(D000213)

⚠ DANGER

Automatic start-up. Disconnect utility power and render unit inoperable before working on unit. Failure to do so will result in death or serious injury.

(D000191)



⚠ DANGER

Electrocution. In the event of electrical accident, immediately shut power OFF. Use non-conductive implements to free victim from live conductor. Apply first aid and get medical help. Failure to do so will result in death or serious injury.

(D000145)



⚠ WARNING

Loss of life. This product is not intended to be used in a critical life support application. Failure to adhere to this warning could result in death or serious injury.

(W000209)

⚠ WARNING

Equipment damage. This unit is not intended for use as a prime power source. It is intended for use as an intermediate power supply in the event of temporary power outage only. Doing so could result in death, serious injury, and equipment damage.

(W000247)

- Competent, qualified personnel should install, operate and service this equipment. Adhere strictly to local, state and national electrical and building codes. When using this equipment, comply with regulations established by the National Electrical Code (NEC), CSA Standard; the Occupational Safety and Health Administration (OSHA), or the local agency for workplace health and safety.
- If working on this equipment while standing on metal or concrete, place insulative mats over a dry wood platform. Work on this equipment only while standing on such insulative mats.
- Never work on this equipment while physically or mentally fatigued.
- Any voltage measurements should be performed with a meter that meets UL3111 safety standards, and meets or exceeds overvoltage class CAT III.

This page intentionally left blank.

Section 2: General Information

Introduction

Thank you for purchasing a Generac transfer switch. This manual has been prepared especially for the purpose of familiarizing personnel with the design, application, installation, operation and servicing of the applicable equipment. Read this manual carefully and comply with all instructions. This will help to prevent accidents or damage to equipment that might otherwise be caused by carelessness, incorrect application, or improper procedures.

Every effort has been expended to make sure that the contents of this manual are both accurate and current. The manufacturer, however, reserves the right to change, alter or otherwise improve the product or manual at any time without prior notice.

Unpacking

Carefully unpack the transfer switch. Inspect closely for any damage that might have occurred during shipment. The purchaser must file with the carrier any claims for loss or damage incurred while in transit.

Check that all packing material is completely removed from the switch prior to installation.

Contents in Loose Parts Bag

- Owner's manual
- Warranty statement
- Manual operating handle (not included in RBU models)
- Storage bracket for manual operating handle (not included in RBU models)
- Fault current label
- Clear decal for fault current label
- Meter gasket
- Top conduit cover gasket

Equipment Description

This automatic transfer switch is used for transferring electrical load from a utility (normal) power source to a generator (standby) power source. Transfer of electrical loads occurs automatically when the utility power source has failed or is substantially reduced and the generator source voltage and frequency have reached an acceptable level. The transfer switch prevents electrical feedback between two different power sources (such as the utility and generator sources) and, for that reason, codes require it in all standby electric system installations.

The transfer switch consists of a transfer mechanism, utility service disconnect circuit breaker (if equipped), and a Smart A/C module incorporating fuses and two terminal blocks for transfer switch connections.

This transfer switch is equipped with a separately accessible Utility Entry cabinet which houses a standard 4 Jaw Meter Socket. It is provided with a means for the Electrical Utility provider to lock. An optional 5th Jaw Kit is available if required.

The lower cabinet contains the Automatic Transfer Switch and Service Disconnect Main Circuit Breaker with Load Shed Module and customer terminations. RBU Models do not come equipped with a transfer switch. They may be upgraded to include a transfer switch with G0074000 Upgrade Kit.

NOTE: Meters are retained by either a Ring or Ringless method. Verify you have the proper type to meet local code requirements.

Transfer Switch Mechanism (RXUW Models or RBU with Upgrade Kit (G007400) Installed)

See [Figure 2-1](#). This switch is used with a single-phase system when the single-phase neutral line is to be connected to a neutral lug and is not to be switched.

Solderless, screw-type terminal lugs are standard.

The conductor size range of the 4 Jaw Meter Socket is as follows:

| Switch Rating | Wire Range | Conductor Tightening Torque |
|---------------|--------------------|-----------------------------|
| 150/200A | #6-250 MCM (Cu/Al) | 275 in-lbs (31 Nm) |

This transfer switch is suitable for control of motors, electric discharge lamps, tungsten filament and electric heating equipment where the sum of motor full load ampere ratings and the ampere ratings of other loads do not exceed the ampere rating of the switch and the tungsten load does not exceed 30 percent of the switch rating.

This ETL listed transfer switch is for use in optional standby systems only (NEC article 702).

A 150A or 200A rated switch is suitable for use on a circuit capable of 22,000 RMS symmetrical amperes, 240 VAC when protected by a circuit breaker without an adjustable short time response or by fuses.

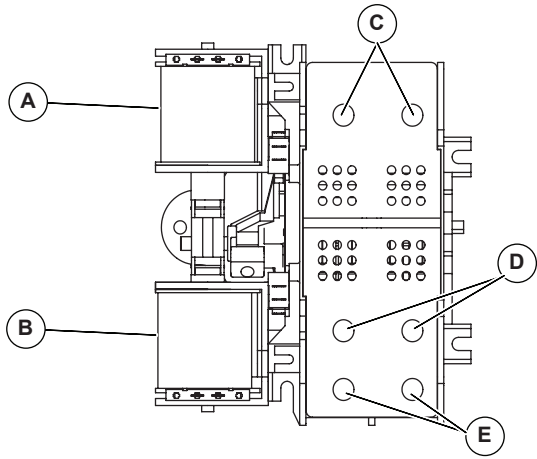

Figure 2-1. Typical Single-Phase ATS Transfer Mechanism

| | |
|---|--------------------------|
| A | Utility Closing Coil |
| B | Generator Closing Coil |
| C | Utility Lugs (N1 & N2) |
| D | Generator Lugs (E1 & E2) |
| E | Load Lugs (T1 & T2) |

Utility Service Circuit Breaker

The utility service circuit breakers for 150/200 amp models are:

- Type 225AF, 2-pole
- 22,000 A/C
- 120/240VAC, 150A/200A
- 50/60 Hertz

Transfer Switch Data Decal

A data decal is permanently affixed to the transfer switch enclosure. Use this transfer switch only with the specific limits shown on the data decal and on other decals and labels that may be affixed to the switch. This will prevent damage to equipment and property.

When requesting information or ordering parts for this equipment, make sure to include all information from the data decal.

For future reference, record the Model and Serial numbers in the space provided on the front cover of this manual.

Transfer Switch Enclosure

The standard switch enclosure is a National Electrical Manufacturer's Association (NEMA) and 3R type. ETL and NEMA 3R (indoor/outdoor rated) type enclosures primarily provide a degree of protection against falling rain

and sleet; are undamaged by the formation of ice on the enclosure.

Safe Use of Transfer Switch



WARNING

Consult Manual. Read and understand manual completely before using product. Failure to completely understand manual and product could result in death or serious injury.

(W000100)

Before installing, operating or servicing this equipment, read the [Safety Rules](#) carefully. Comply strictly with all [Safety Rules](#) to prevent accidents and/or damage to the equipment. The manufacturer recommends that a copy of the [Safety Rules](#) be posted near the transfer switch. Also, be sure to read all instructions and information found on tags, labels and decals affixed to the equipment.

Three publications that outline the safe use of transfer switches are the following:

- NFPA 70; National Electrical Code
- UL 1008; STANDARD FOR SAFETY-AUTOMATIC TRANSFER SWITCHES
- UL 67; Panelboards Marking and Application Guide

NOTE: It is essential to use the latest version of any standard to ensure correct and current information.

Load Management Options

Load management systems are designed to work together to prevent a generator from being overloaded by large appliance loads. A Smart A/C Module (SACM) is provided as standard equipment with this switch. An optional Smart Management Module (SMM) is also available.

Accessories

| Accessory | Description |
|---|---|
| G0074000 RBU Transfer Switch Upgrade Kit | Includes all pieces to perform conversion of a RBU Meter Main into a RXUW Transfer Switch. |
| G0074010 Ring Style Meter Cover | Replacement outer top cover and sealing ring for ring style meter retainment. Verify you have the proper type to meet local code requirements. |
| G0074020 Fifth Jaw Metering Kit | Includes all pieces necessary to perform conversion of the standard Four Jaw Meter Socket into a Five Jaw Meter Socket. Verify transfer switch has the proper type to meet local code requirements. |
| G0074030 Horn Bypass | Replacement meter jaws for horn bypass type meter sockets. Verify you have the proper type to meet local code requirements. |
| G0074040 Meter Safety Flash Shield | Safety flash shield for standard and horn bypass type meter jaws. Used with ring-less style meter retainment. |
| G0074050 Side Connection Lug Kit | Includes all pieces necessary to convert the standard four jaw meter socket into a socket with side lug line connections. |
| G0074060 24 in. Pedestal Extension | Includes all pieces to extend the transfer switch enclosure by 24 in. for underground service feed. |
| G0074070 48 in. Pedestal Extension | Includes all pieces to extend the transfer switch enclosure by 48 in. for underground service feed. |
| G0074080 Ringless Cover | Replacement outer top cover for Ringless style meter retainment. Verify transfer switch has the proper type to meet local code requirements. |
| G074100 Tamper Proof Lid | Tamper proof assembly used with ring style meter retainment. Verify transfer switch has the proper type to meet local code requirements. |
| G0074130 Accessory Kit Utility Barrel Lock | Includes all pieces to lock a ringless upper meter cover with a utility supplied barrel lock per local utility requirements. |
| A0000018981 Ultrasonic Cleaner Solution | Cleaning solution safe for metal and plastic surfaces. Contains 1 gal (128 oz). |
| A0000019001 Corrosion Inhibitor and Protectant | Protectant for outdoor plastic, rubber, leather and vinyl surfaces. Contains 0.12 gal (15 oz). |

Smart A/C Module (SACM)

Up to four air conditioner loads can be managed by the SACM. The SACM manages the loads by “shedding” the connected loads in the event of a drop in generator frequency (overload). Loads to be “shed” are in 4 priority levels on the module.

See [Figure 2-2](#). Priorities A/C 1-4 (A) have connections for an air conditioner. To control an air conditioner, no additional equipment is required. Internal normally closed relays interrupt the 24 VAC thermostat control signal to disable the air conditioner load.

Four LEDs, located on the SACM (B), illuminate when a load is connected and powered.

See [Figure 2-2](#). The SACM has a test button (C) used to simulate an overload condition. This button operates even when the transfer signal is inactive. The Generator Control Wiring is connected to terminals (D).

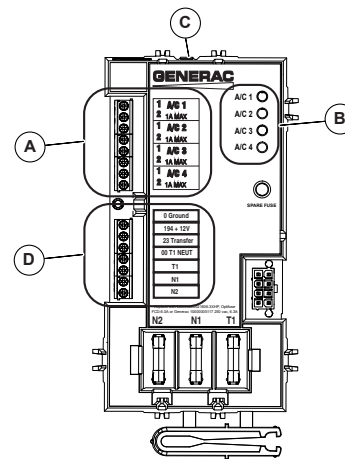

015523

Figure 2-2. Smart A/C Module (SACM)

Smart Management Module (SMM) (sold separately)

Any loads, including central air conditioners, can be managed using a Smart Management Module (SMM). The system can accommodate up to eight individual SMMs.

NOTE: SMMs are self-contained and have individual built-in controllers.

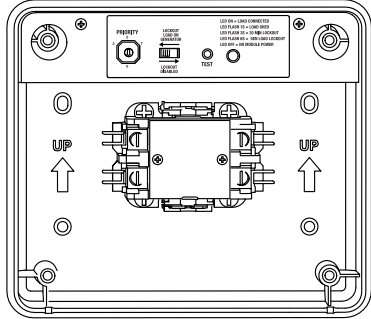

Figure 2-3. Smart Management Module (SMM)

| Priority | Recovery Time | SACM | SMM |
|----------|----------------------|------|-----|
| 6 | 6 minutes 15 seconds | NA | Yes |
| 7 | 6 minutes 30 seconds | NA | Yes |
| 8 | 6 minutes 45 seconds | NA | Yes |

Refer to the SMM Owner's/Installation Manual for detailed characteristics and specifications of that product.

Application Considerations

Generator overload condition is determined by generator frequency. Loads are shed when frequency is less than 58 Hz for three seconds or less than 50 Hz for ½ second (for 60 Hz systems).

The SACM can be used in conjunction with individual SMMs to manage a combined total of eight loads.

- Use Priorities A/C 1-4 on the SACM as the top priorities, then up to four SMMs as Priorities 5-8.
- Use only select A/C priorities on the SACM as the top priorities, then use additional SMMs as the remaining priorities.
- A SMM can share a priority with an A/C priority on the SACM provided the generator is sized to handle the combined surge load from both appliances. Sharing priorities can allow up to 12 loads to be managed in a properly sized system.

In any combination of modules, the recovery times after a loss of utility power or shutdown due to overload are shown in [Table 2-1](#).

Table 2-1. Priority Settings

| Priority | Recovery Time | SACM | SMM |
|----------|----------------------|------|-----|
| 1 | 5 minutes | Yes | Yes |
| 2 | 5 minutes 15 seconds | Yes | Yes |
| 3 | 5 minutes 30 seconds | Yes | Yes |
| 4 | 5 minutes 45 seconds | Yes | Yes |
| 5 | 6 minutes | NA | Yes |

Section 3: Installation

Introduction to Installation

Though this equipment has been wired and tested at the factory, the installer should verify all wiring connections are proper. Installing the switch includes the following procedures:

- Mounting the enclosure.
- Connecting power source and load leads.
- Connecting the generator start and sensing circuit.
- Connecting any auxiliary contact (if needed).
- Testing functions.

Mounting

Mounting dimensions for the transfer switch enclosure are in this manual. Enclosures are typically wall-mounted. See [Drawings and Diagrams](#).

⚠ DANGER

Equipment Malfunction. Installing a dirty or damaged transfer switch will cause equipment malfunction and will result in death or serious injury.

(D000119)

This transfer switch is mounted in a ETL type 3R enclosure. It can be mounted outside or inside and should be based on the layout of installation, convenience and proximity to the utility supply and load center.

Install the transfer switch as close as possible to the electrical loads that are to be connected to it. Mount the switch vertically to a rigid supporting structure. To prevent switch distortion, level all mounting points. If necessary, use washers behind mounting holes to level the unit.

NOTE: This Generac ATS contains utility metering equipment and must be installed as the service equipment in accordance with the requirements in NEC Article 230, unless alternate upstream service equipment is installed.

Open Enclosure

1. See [Figure 3-1](#). First, remove outer top cover (A):
 - a. Rotate latch (B) clockwise until clear of latch hole.

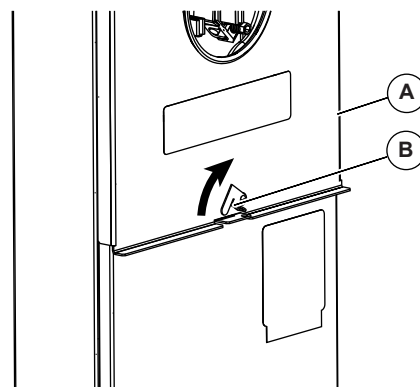

Figure 3-1. Rotate Latch

010086

- b. See [Figure 3-2](#). Tilt cover as shown and pull away from enclosure.

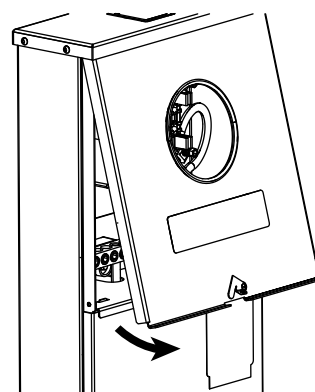

Figure 3-2. Tilt Cover

010087

2. See [Figure 3-3](#). Remove outer bottom cover (C):
 - a. Remove thumb screw (D).
 - b. Slide slot (E) over retention tab.
 - c. Lower cover until clear of flange (F), and pull away from enclosure.
3. Remove inner panel (G):
 - a. Loosen nut (H) until it clears t-slot (I) in inner panel.
 - b. Grasp inner panel at two cutouts (J—left and right). Tilt inner panel as shown, passing nut through t-slot.
 - c. Lower inner panel until clear of two retention slots (K—left and right sides), and pull away from enclosure.

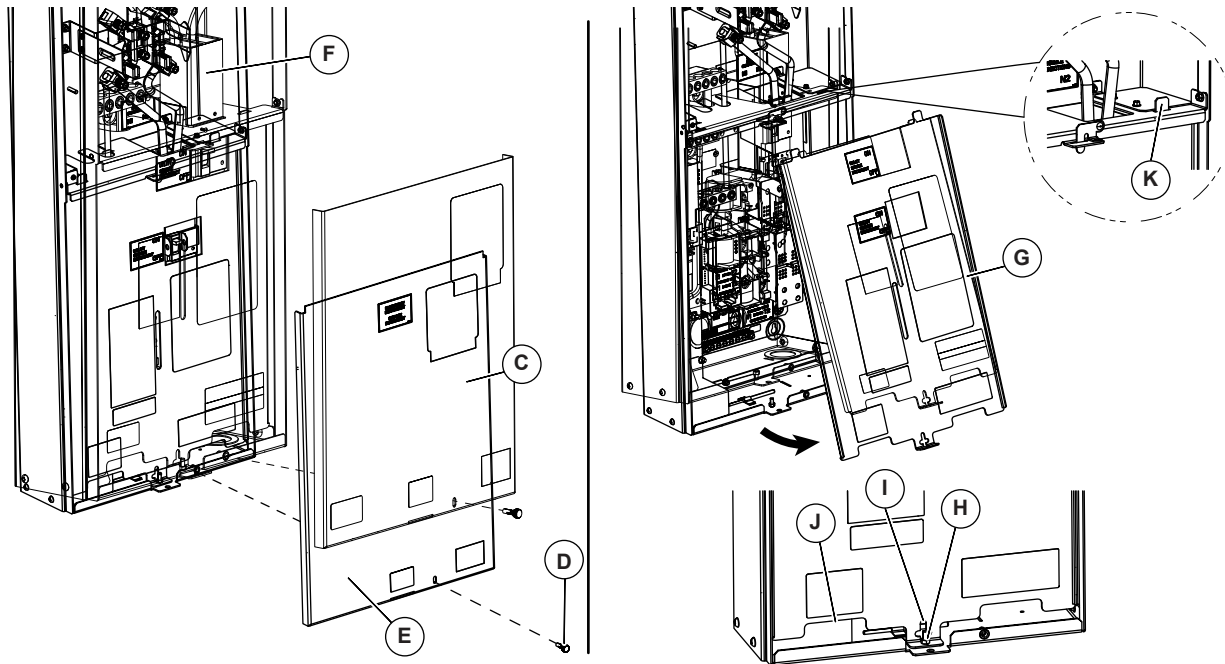

Figure 3-3. Open Enclosure

010088a

Connecting Power Source (RBU and RXUW)



DANGER

Electrocution. Turn utility and emergency power supplies to OFF before connecting power source and load lines. Failure to do so will result in death or serious injury.

(D000116)

Installation and interconnection diagrams are provided in this manual.

NOTE: All installations must comply with national, state and local codes. It is the responsibility of the installer to perform an installation that will pass the final electrical inspection.

1. Select the upper or one of the lower utility cable entry points.

NOTE: If utilizing the upper utility cable entry point, skip to Step 5. If not utilizing the upper utility cable entry point, complete Step 2 through Step 4.

2. Align top conduit cover gasket (A0004457710) with the extruded holes in the top of the switch.
3. See [Figure 3-4](#). Align the cover (A) with the holes and the gasket (B).

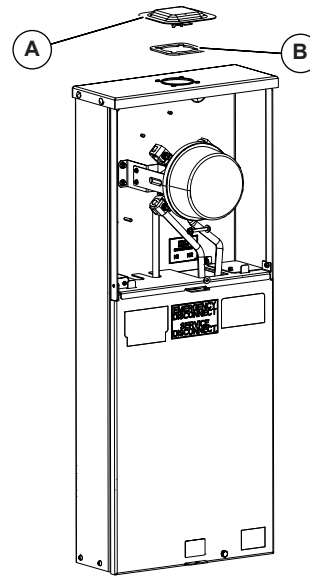

Figure 3-4. Install Top Cover

015530a

4. Tighten the wingnut finger tight.
5. See [Figure 3-7](#). Connect utility supply at the Four Jaw Meter Socket terminals N1 and N2. Follow torque specifications listed on the circuit breaker. Available utility entry points are the top or the bottom left.
6. Connect utility grounded conductor to the Upper Neutral and Ground terminals. Neutral and Ground terminals are bonded to each other with a jumper wire (A).
7. If applicable, connect Solar directly to Utility at S1 and S2 with Lugs provided on bus under circuit breaker cover as local codes permit.

8. Utility authorized personnel may install the meter into the meter socket.

NOTE: Neutral to Ground jumper wire (A) is provided for use if required by local codes.

IMPORTANT NOTE: The meter cover gasket (A0004487268) should be left for an utility authorized personnel to install. The top cover gasket **MUST** be installed prior to utility servicing the unit.

NOTE: If applicable, install any required accessory kits; such as, tamperproof upper cover or barrel lock. See available accessory kits in [Drawings and Diagrams](#). Follow installation instructions included with accessories.

9. See [Figure 3-5](#) and [Figure 3-6](#). Slide provided Meter Gasket (A0004487268) over the meter.

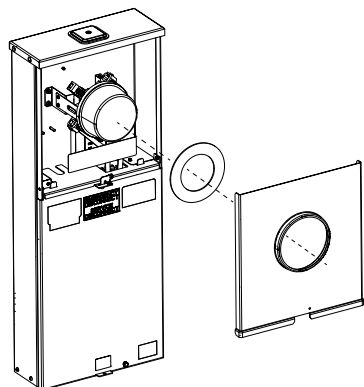

015522

Figure 3-5. Installing Meter Gasket

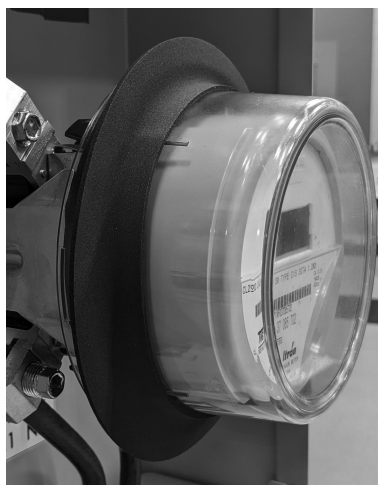

015525

Figure 3-6. Slide Gasket Over Meter

10. The Upper Utility Access Panel may now be installed and sealed as required by local utility.

Connecting Alternate Power Source (RXUW Only)

1. See [Figure 3-7](#). Connect generator to the generator terminals (E1 and E2) on the transfer mechanism.
2. Connect the generator neutral wire to the neutral lug.

IMPORTANT NOTE: A jumper wire bonds the neutral lug for optional 5th Jaw Kit installation. **NEVER** remove this wire.

3. Connect the subpanel supply to lower T1 and T2 Terminals. Connect subpanel Neutral and Ground to lower Neutral (C1) and Ground (C2) bars.

Conductor sizes must be adequate to handle the maximum current to which they will be subjected, based on the 75 Å°C column of tables and charts used to size conductors. The installation must comply fully with all applicable codes, standards, and regulations.

Knockouts into the transfer switch can be made in the field as needed for entry of power cables and conduit. Conduit entry shall maintain the proper wire bending spaces required by Tables 312.6 (A) and (B) in the NEC. Conduits should be arranged to provide separation between the Utility and Generator supply conductors inside the enclosure.

For transfer switches installed in wet locations, power cables or conduits entering above the level of uninsulated live parts shall use fittings listed for use in wet locations as required by 312.2 in the NEC.

NOTE: If aluminum conductors are used, apply corrosion inhibitor to conductors. After tightening terminal lugs, carefully wipe away any excess corrosion inhibitor.

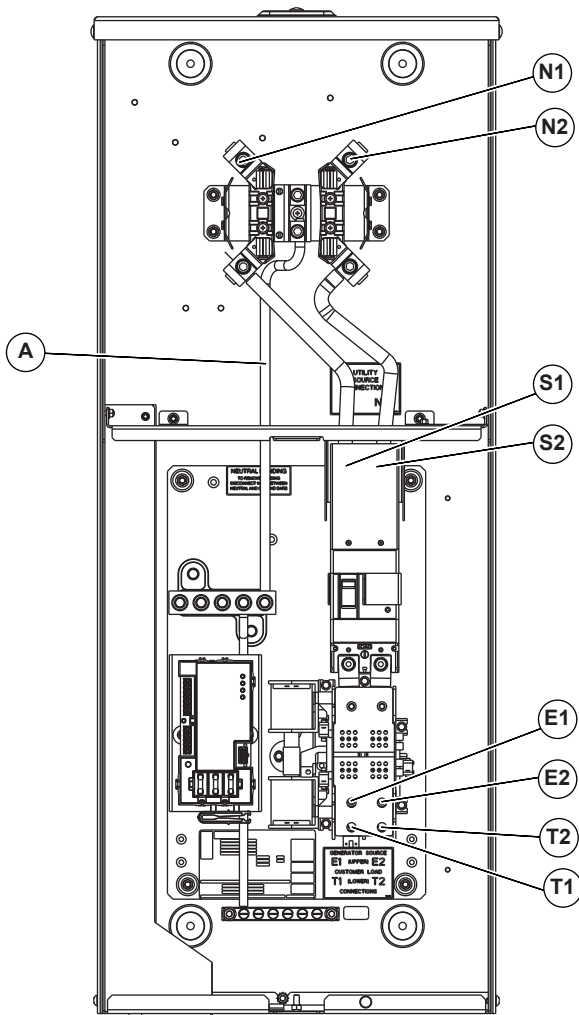

Figure 3-7. Wiring Connections

Tighten terminal lugs to the torque values as noted on the decal located on the inside of the door. After tightening terminal lugs, carefully wipe away any excess corrosion inhibitor.

CAUTION

Equipment damage. Verify all conductors are tightened to the factory specified torque value. Failure to do so could result in damage to the switch base.

(C000120)

Connecting Start Circuit Wires

See [Figure 3-8](#). Control system interconnections consist of 0, 194, 23, 00, T1, N1, and N2.

NOTE: Generac Type TC-ER-JP power and control tray cable can be installed as permitted by the 2017 and 2020 NEC. Type TC-ER-JP cable contains color-coded power and control conductors.

The generator control wiring is a Class 1 signaling circuit. Reference instruction manual of specific engine generator for wiring connection details. Screw heads are straight bladed and cross-bladed, and should be tightened to 3.5 in-lb (0.4 Nm).

Recommended wire gauge sizes depend on wire length as specified in the following chart:

| Recommended Wire Size | Maximum Wire Length |
|-----------------------|--|
| | (One transfer switch and load shed module) |
| No. 18 AWG | 1–115 ft (0.3–35 m) |
| No. 16 AWG | 116–185 ft (36–56 m) |
| No. 14 AWG | 186–295 ft (57–89 m) |
| No. 12 AWG | 296–460 ft (90–140 m) |

Consult factory if more than one transfer switch and SACM will be operated.

Exception: Conductors of AC and DC circuits, rated 1000 volts nominal, or less, shall be permitted to occupy the same equipment, cable, or conduit. All conductors shall have an insulation rating equal to at least the maximum circuit voltage applied to any conductor within the equipment, cable, or conduit. See NEC 300.3(C)(1).

Typical SACM Connections

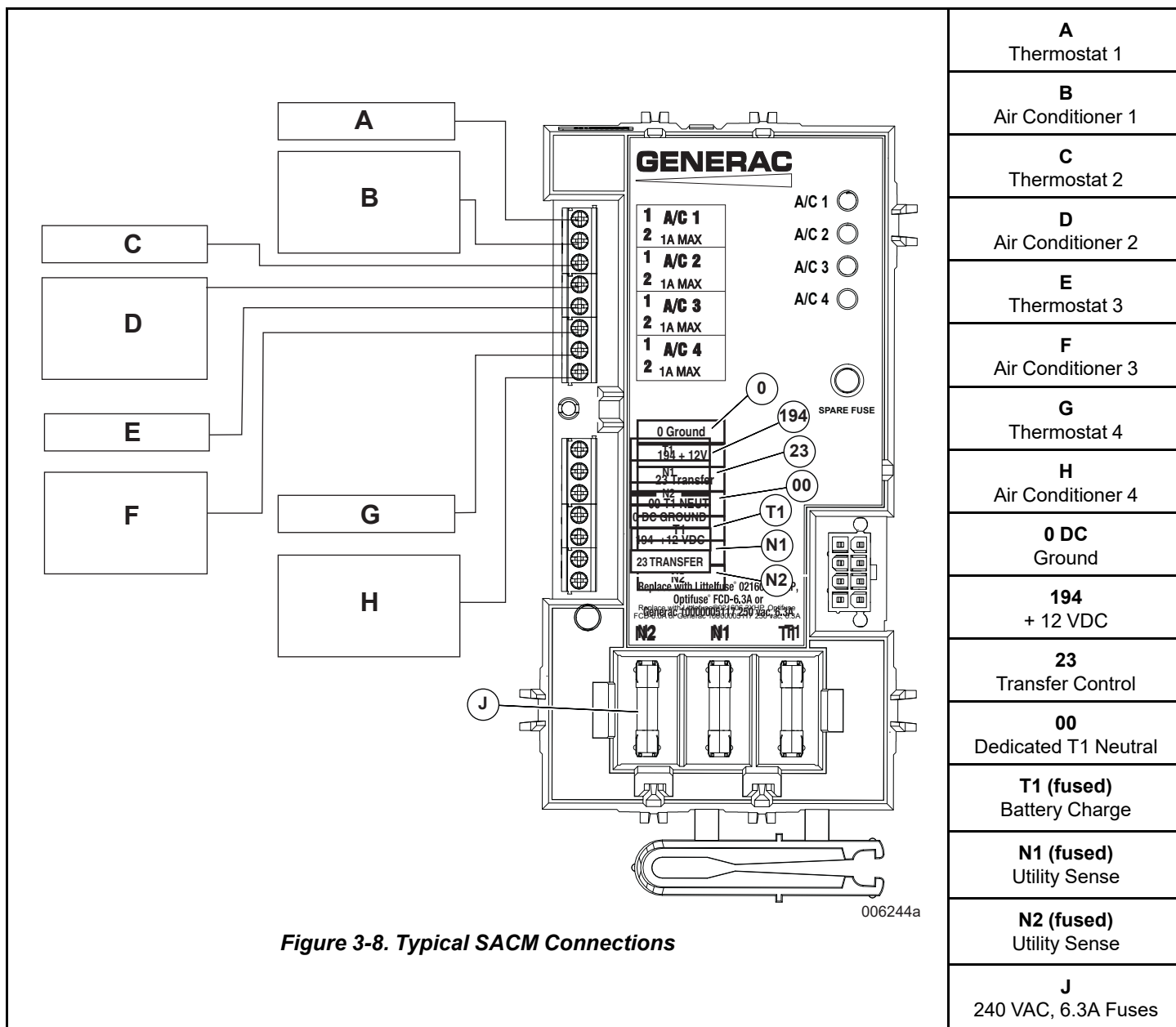

Connecting SACM

See [Figure 3-8](#). The SACM can control an air conditioner (24 VAC) directly.

Control of Air Conditioner Load

1. Route the thermostat cable (from the furnace/thermostat to the outdoor air conditioner unit) to the transfer switch.
2. See [Figure 3-8](#). Connect the wire to the terminal strip terminals (A/C 1) on the SACM. These are normally closed contacts which open upon load shed conditions. Route thermostat wire away from high voltage wires.

3. If required, connect additional air conditioners to the terminal strip terminals (A/C 2-4).

| Contact Ratings | |
|-----------------|---------------------|
| A/C 1-4 | 24 VAC, 1.0 Amp Max |

NOTE: These instructions are for a typical air conditioner installation. Control of certain heat pumps and 2-stage air conditioners may require special connections or the use of SMMs to control the loads.

Auxiliary Contact

See [Figure 3-9](#). If desired, there is one normally-closed Auxiliary Contact (A) on the transfer switch to operate customer accessories, remote advisory lights, or remote

annunciator devices. A suitable power source must be connected to the common terminal. If needed, an extra auxiliary contact can be added.

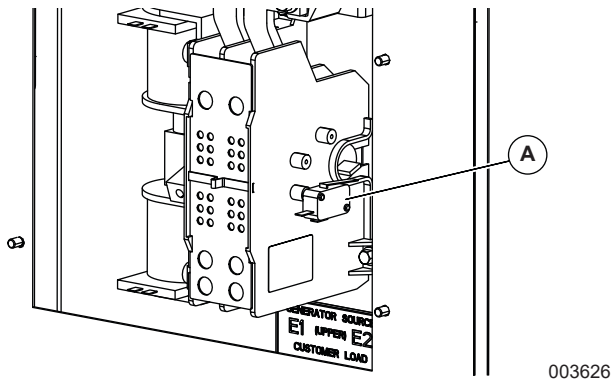

Figure 3-9. Auxiliary Contact

The auxiliary contact is normally closed when the transfer switch is in utility mode. The contacts will open when the transfer switch is in the standby power mode.

NOTE: Auxiliary Contact is rated 10 amps at 125 or 250 volts AC, and 0.6 amps at 125 volts DC.



Equipment damage. Verify that voltage and current are within specification before energizing this equipment. Exceeding rated voltage and current will damage the auxiliary contacts.

(C000134)

Fault Current Label

See [Figure 3-10](#). A Fault Current Identification Label is provided in the bag containing the unit Owner's Manual and transfer switch manual operating handle. The 2017 NEC requires that the short-circuit current rating of the transfer equipment, based on the type of overcurrent protective device protecting the transfer equipment, be field marked on the exterior of the transfer equipment. For NEC compliance, verify the required short-circuit current rating of the transfer switch before installation. The completed label provides the local AHJ (Authority Having Jurisdiction) with the information he or she may require during inspection.

Apply the label to the exterior of the transfer switch enclosure. Use a pen to fill in the required information, and then cover the label with the clear protective decal.

| | |
|--------------------------------|-------|
| FAULT CURRENT RATING | _____ |
| AVAILABLE FAULT CURRENT | _____ |
| DATE | _____ |

004496

Figure 3-10. Fault Current Label

Install Upgrade Kit G0074000 (RBU Only)

1. See [Figure 3-11](#). Remove screws (A) from bus bar assembly and set aside.
2. Remove screws (B) from bus bar assembly and remove assembly from sub panel.

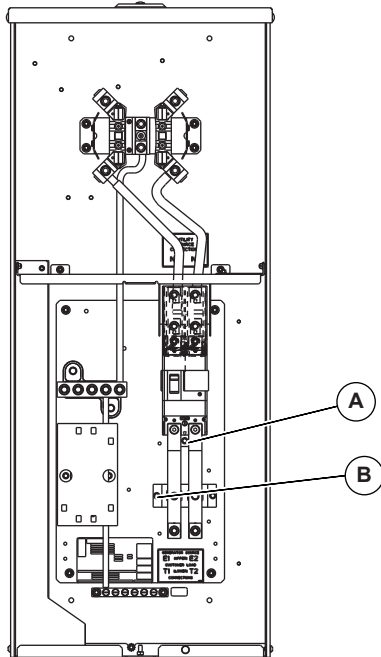

Figure 3-11. Remove Bus Bar Assembly

3. See [Figure 3-12](#). Use provided M5 screws (C) to install transfer switch assembly from kit G0074000.

4. Install screws (A) from step 1 and tighten to 72 in-lbs onto circuit breaker.
5. Install SACM unit from kit G074000 into bracket provided (D).
6. Plug harness with 8 pin connector into SACM unit (D).
7. For connecting power and signal wiring, please refer to [Connecting Power Source \(RBU and RXUW\)](#), [Connecting Alternate Power Source \(RXUW Only\)](#), [Connecting Start Circuit Wires](#), and [Connecting SACM](#).

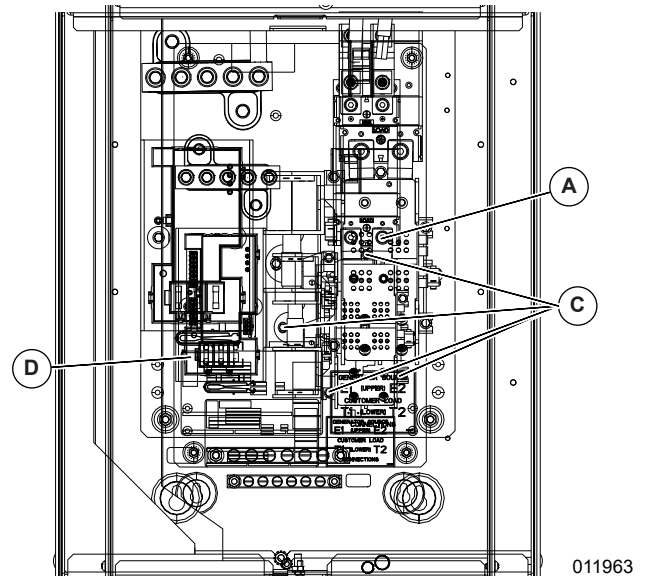

Figure 3-12. Install Kit G0074000

This page intentionally left blank.

Section 4: Operation (RXUW Models and Upgraded RBU)

Functional Tests and Adjustments

Following transfer switch installation and interconnection, inspect the entire installation carefully. A competent, qualified electrician should inspect it. The installation should comply strictly with all applicable codes, standards, and regulations. When absolutely certain the installation is proper and correct, complete a functional test of the system.

CAUTION

Equipment damage. Perform functional tests in the exact order they are presented in the manual. Failure to do so could result in equipment damage.

(C000121)

IMPORTANT NOTE: Before proceeding with functional tests, read and make sure all instructions and information in this section is understood. Also read the information and instructions of labels and decals affixed to the switch. Note any options or accessories that might be installed and review their operation.

Manual Operation



DANGER

Electrocution. Do not manually transfer under load. Disconnect transfer switch from all power sources prior to manual transfer. Failure to do so will result in death or serious injury, and equipment damage.

(D000132)

See . A manual handle (B) is shipped with the transfer switch. Manual operation must be checked BEFORE the transfer switch is operated electrically. To check manual operation, proceed as follows:

1. Verify the generator is OFF.
 2. Turn OFF both utility (service disconnect circuit breaker) and emergency (generator main line circuit breaker) power supplies to the transfer switch.
 3. Note position of transfer mechanism main contacts (A) by observing the movable contact carrier arm. This can be viewed through the long narrow slot in the inside cover. The top of the movable contact carrier arm is yellow for easy identification.
- Manual operation handle in the UP position - LOAD terminals (T1, T2) are connected to utility terminals (N1, N2).

- Manual operation handle in the DOWN position -LOAD terminals (T1, T2) are connected to EMERGENCY terminals (E1, E2).

CAUTION

Equipment damage. Do not use excessive force while manually operating the transfer switch. Doing so could result in equipment damage.

(C000122)

Close to Utility Source Side

Before proceeding, verify the position of the switch by observing the position of manual operation handle in . If the handle is UP, the contacts are closed in the utility (normal) position, no further action is required. If the handle is DOWN, proceed with Step 1.

1. With the handle inserted into the movable contact carrier arm, move handle UP. Be sure to hold on to the handle as it will move quickly after the center of travel.
2. Remove manual operating handle from movable contact carrier arm. Return handle to storage bracket.

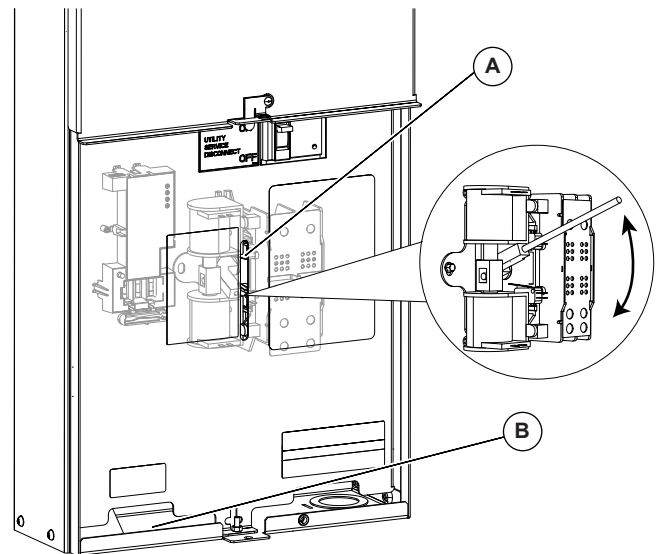

010497

Figure 4-1. Manual Operation

Close to Generator Source Side

Before proceeding, verify the position of the switch by observing the position of the manual operation handle in [Figure 4-1](#). If the handle is DOWN, the contacts are

closed in the generator (standby) position; no further action is required. If the handle is UP, proceed with Step 1.

1. With the handle inserted into the movable contact carrier arm, move the handle DOWN. Be sure to hold on to the handle as it will move quickly after the center of travel.
2. Remove manual operating handle from movable contact carrier arm. Return handle to storage bracket.

Return to Utility Source Side

1. Manually actuate switch to return manual operating handle to the UP position.
2. Remove manual operating handle from movable contact carrier arm. Return handle to storage bracket.

Voltage Checks

NOTE: Use the Digital Multimeter (DMM) LowZ low input impedance setting to collect accurate voltage measurements. LowZ eliminates the possibility of inaccurate ghost voltage readings, also known as phantom voltage or stray voltage readings. See DMM manufacturer's literature for additional information.

Generator Voltage Checks



⚠ DANGER

Electrocution. High voltage is present at transfer switch and terminals. Contact with live terminals will result in death or serious injury.

(D000129)

1. On the generator panel, select the MANUAL mode of operation. The generator should crank and start.
2. Let the generator stabilize and warm up at no-load for at least five minutes.
3. Set the generator's main circuit breaker (CB1) to its ON or CLOSED position.
4. With an accurate AC voltmeter and frequency meter, check the no-load, voltage and frequency. Measure across ATS terminal lugs E1 to E2; E1 to NEUTRAL and E2 to NEUTRAL.

| | |
|-------------------------|-------------|
| Frequency | 60–62 Hz |
| Terminals E1 to E2 | 240–246 VAC |
| Terminals E1 to NEUTRAL | 120–123 VAC |
| Terminals E2 to NEUTRAL | 120–123 VAC |

5. When certain that generator supply voltage is correct and compatible with transfer switch ratings,

turn OFF the generator supply to the transfer switch.

6. Set the generator main circuit breaker (CB1) to OFF or OPEN.
7. On the generator panel, select the OFF mode to shut down the generator.

Do NOT proceed until generator AC output voltage and frequency are correct and within stated limits. If the no-load voltage is correct but no-load frequency is incorrect, the engine governed speed may require adjustment. If no-load frequency is correct but voltage is not, the voltage regulator may require adjustment.

Utility Voltage Checks



⚠ DANGER

Electrocution. High voltage is present at transfer switch and terminals. Contact with live terminals will result in death or serious injury.

(D000129)

1. Turn ON the utility power supply to the transfer switch using the utility service disconnect circuit breaker.
2. With an accurate AC voltmeter, check for correct voltage. Measure across ATS terminal lugs N1 and N2; N1 to NEUTRAL and N2 to NEUTRAL.

Generator Tests Under Load

1. Set the generator main circuit breaker to OFF or OPEN.
2. Set the utility service disconnect circuit breaker of the transfer switch to OFF or OPEN, and turn OFF or OPEN all load circuit breakers.
3. Manually actuate the transfer switch main contacts to the emergency (standby) position. See [Manual Operation](#).
4. To start the generator, select the MANUAL mode of operation. When engine starts, let it stabilize for a few minutes, and close lid (if applicable).
5. Set the generator main circuit breaker to ON or CLOSED. The generator now powers all LOAD circuits. Check generator operation under load as follows:
 - a. Turn on electrical loads to the full rated wattage/ampere capacity of the generator. DO NOT OVERLOAD.
 - b. With maximum rated load applied, check voltage and frequency across transfer switch terminals E1 and E2. Voltage should be greater than 230 VAC (240 VAC system); frequency should be greater than 59 Hz.

- c. Verify that the gas pressure remains within acceptable parameters (see the generator Installation manual).
 - d. Let the generator run under rated load for at least 30 minutes. With unit running, watch for unusual noises, vibration, or overheating that might indicate a problem.
6. When checkout under load is complete, set main circuit breaker of the generator to the OFF or OPEN position.
 7. Let the generator run at no-load for several minutes. Then, shut down by selecting the OFF mode.
 8. Move the main switch contacts back to the utility position.
- NOTE:** See [Manual Operation](#). Handle and operating lever of transfer switch should be in down position.
9. Set the utility service disconnect circuit breaker of the transfer switch to ON or CLOSED.
 10. The system is now set for fully automatic operation.

Checking Automatic Operation

To check the system for proper automatic operation, proceed as follows:

1. Verify generator is OFF.
2. Set the utility service disconnect circuit breaker of the transfer switch to OFF or OPEN.
3. Verify switch is de-energized.
4. Install front cover of the transfer switch.
5. Set the utility service disconnect circuit breaker of the transfer switch to ON or CLOSED.
6. Set the generator main circuit breaker to ON.
7. On the generator panel, select AUTO. The system is now ready for automatic operation.
8. Set the utility service disconnect circuit breaker of the transfer switch to OFF or OPEN.

With the generator ready for automatic operation, the engine should crank and start when the utility source power is turned OFF after a five second delay (factory default setting). After starting, the transfer switch should connect load circuits to the standby side after a five (5) second warm-up delay. Let the system operate through its entire automatic sequence of operation.

NOTE: Timer durations may differ between generators and settings.

With the generator running and loads powered by generator AC output, set the utility service disconnect circuit breaker of the transfer switch to ON or CLOSED. The following should occur:

- After approximately 15 seconds, the switch should transfer loads back to the utility power source.
- Approximately one minute after re-transfer, the generator should shut down.

With the generator in the AUTOMATIC mode, the system is now set for fully automatic operation.

Installation Summary

1. Verify the installation has been properly performed as outlined by the manufacturer and that it meets all applicable laws and codes.
2. Verify proper operation of the system as outlined in the appropriate installation and owner's manuals.
3. Educate the end-user on the proper operation, maintenance and service call procedures.

NOTE: The Utility Power Circuit Breaker in the transfer switch must be turned OFF to simulate a utility outage. Shutting off the main disconnect in a subpanel connected to the transfer switch will NOT simulate an outage.

Shutting Generator Down While Under Load or During a Utility Outage



Automatic start-up. Disconnect utility power and render unit inoperable before working on unit. Failure to do so will result in death or serious injury.

(D000191)

IMPORTANT NOTE: To avoid equipment damage, follow these steps, in order, during utility outages. Shut-downs may be required during utility outages to perform routine maintenance or to conserve fuel.

1. To turn generator OFF:
 - a. Set utility MLCB to OFF (OPEN).
 - b. Set generator MLCB (generator disconnect) to OFF (OPEN).
 - c. Allow generator to run for cool-down for approximately one minute.
 - d. Set generator to OFF at the controller.
 - e. Remove 7.5A fuse from controller.
2. To turn generator back ON:
 - a. Install 7.5A fuse in controller.
 - b. Verify generator MLCB (generator disconnect) is OFF (OPEN).
 - c. Set generator to AUTO mode at the controller.
 - d. Generator will start and run. Allow generator to run and warm up for a few minutes.
 - e. Set generator MLCB (generator disconnect) to ON (CLOSED).

- f. Set utility MLCB to ON (CLOSED).

The system now operates in automatic mode.

Preparing for Maintenance



Automatic start-up. Disconnect utility power and render unit inoperable before working on unit. Failure to do so will result in death or serious injury.

(D000191)

1. To turn the generator OFF:
 - a. At the controller, turn the generator OFF.
 - b. Set the MLCB (generator disconnect) on the generator to OFF (OPEN).
 - c. Turn the main utility disconnect OFF (OPEN).
 - d. Remove 7.5A fuse from the controller.
 - e. Follow maintenance procedure(s).
2. To turn the generator back ON:
 - a. Turn the main utility disconnect ON (CLOSED).
 - b. Install 7.5A fuse in controller.
 - c. Put the generator into AUTO mode.
 - d. Set the MLCB (generator disconnect) on the generator to ON (CLOSED).

The system is now in automatic mode.

Testing the SACM

A “Test” pushbutton is provided on top of the SACM to test the operation of the load shed functions. The test pushbutton will work when the ATS is in the utility or the generator position.

Proceed as follows to test the SACM:

1. Turn on the utility supply to the ATS.
2. Verify managed loads are powered and all LEDs illuminate on SACM.
3. Press the TEST button on the SACM.
4. Verify that all of the connected loads to be “shed” become disabled.
5. After five (5) minutes verify A/C 1 is energized and Status LED A/C 1 is ON.
6. After another 15 seconds, verify A/C 2 is energized and Status LED A/C 2 is ON.
7. After another 15 seconds, verify Load A/C 3 is energized and Status LED Load A/C 3 is ON.
8. After another 15 seconds, verify A/C 4 is energized and Status LED A/C 4 is ON.

SACM Fuse Service

See [Figure 4-2](#). A fuse removal and installation tool (A) is included in the SACM housing.

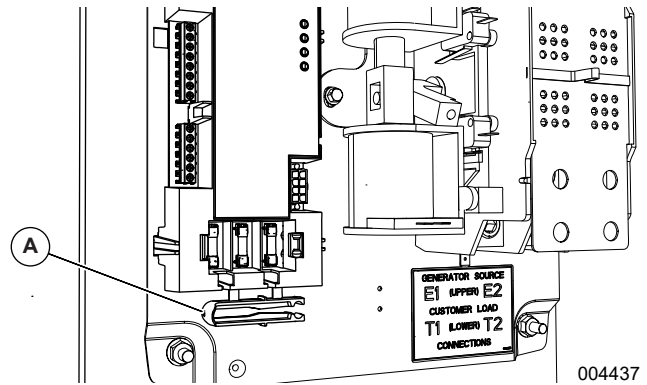

Figure 4-2. Fuse Removal and Installation Tool

If a fuse requires replacement, snap the tool free with an appropriate tool such as diagonal pliers, and use it to replace the fuse. The tool can be stored in the SACM housing retainer directly above the fuses, with the large thumb tab facing out.

Use only Generac replacement fuses — part number 1000005117, rated 240 VAC, 6.3 Amps, 10,000 AIC.

Alternative fuses are Littelfuse® 021606.3MXP or Optifuse® FCD-6.3.

Section 5: Drawings and Diagrams

Installation Drawings—150-200A SER Meter Main

No. A0000258227-C

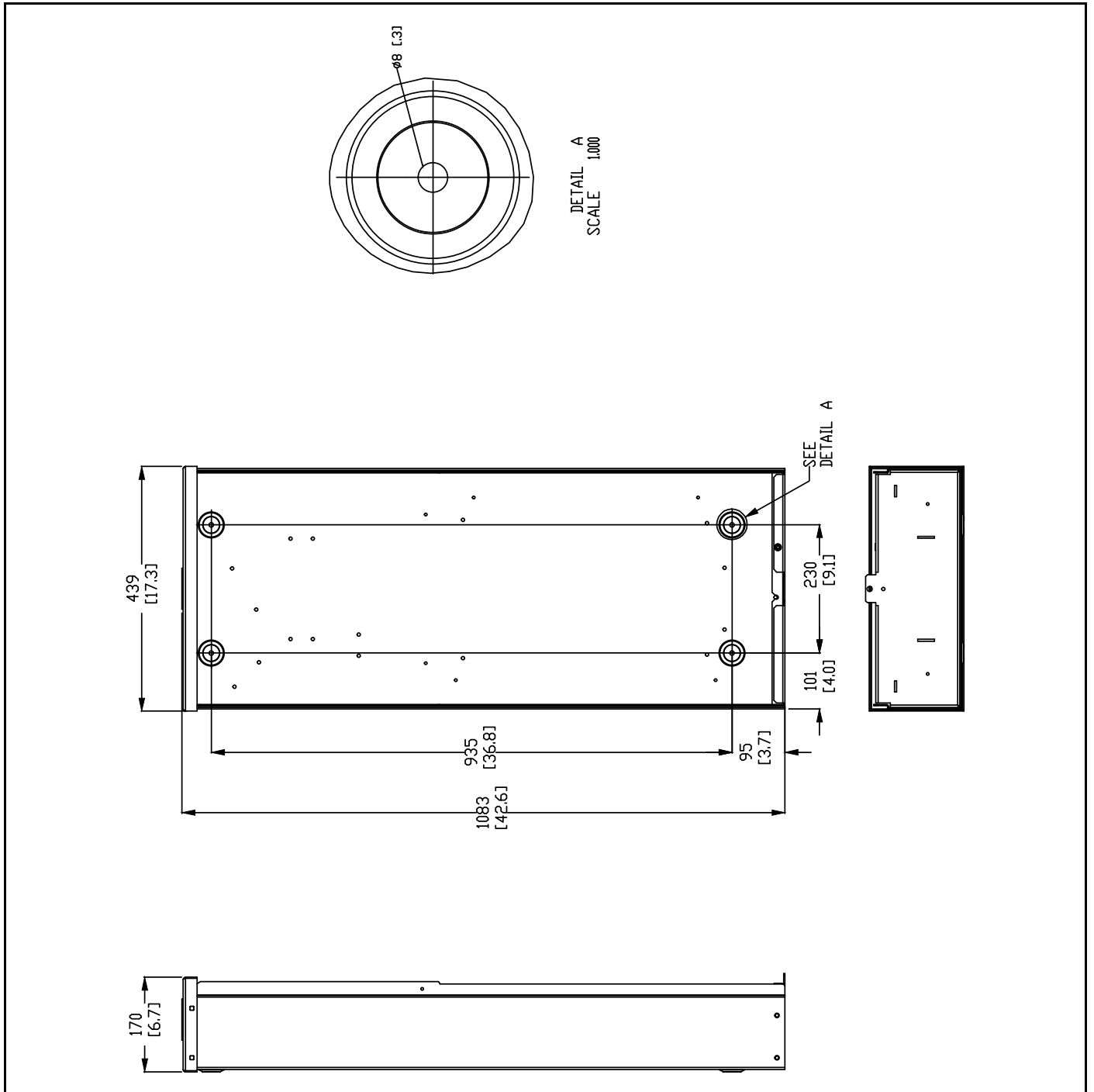

Interconnection Drawings—Liquid-Cooled Generator

No. A0000258228-D (Part 1 of 2)

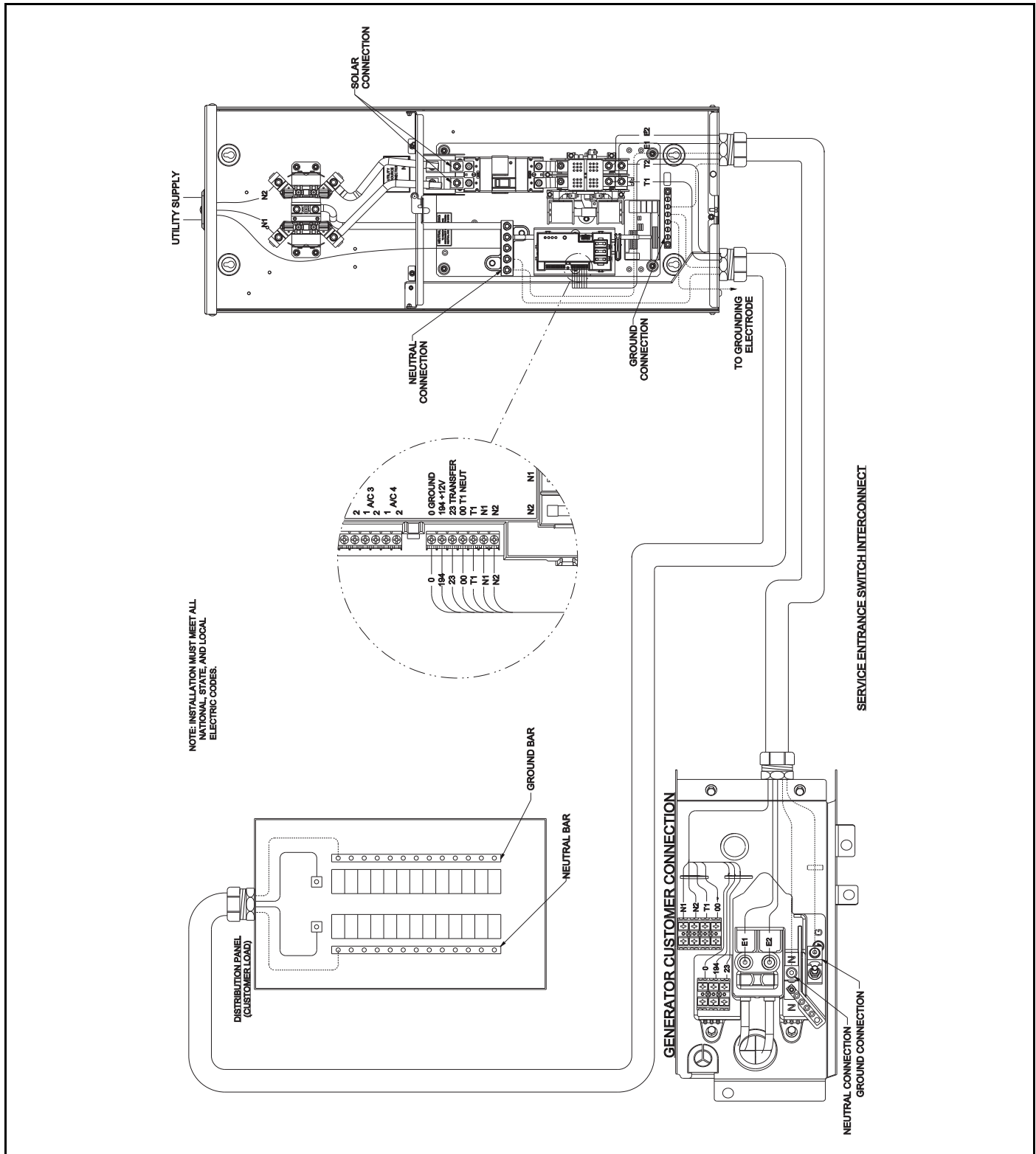

Interconnection Drawings—Liquid-Cooled Generator

No. A0000258228-D (Part 2 of 2)

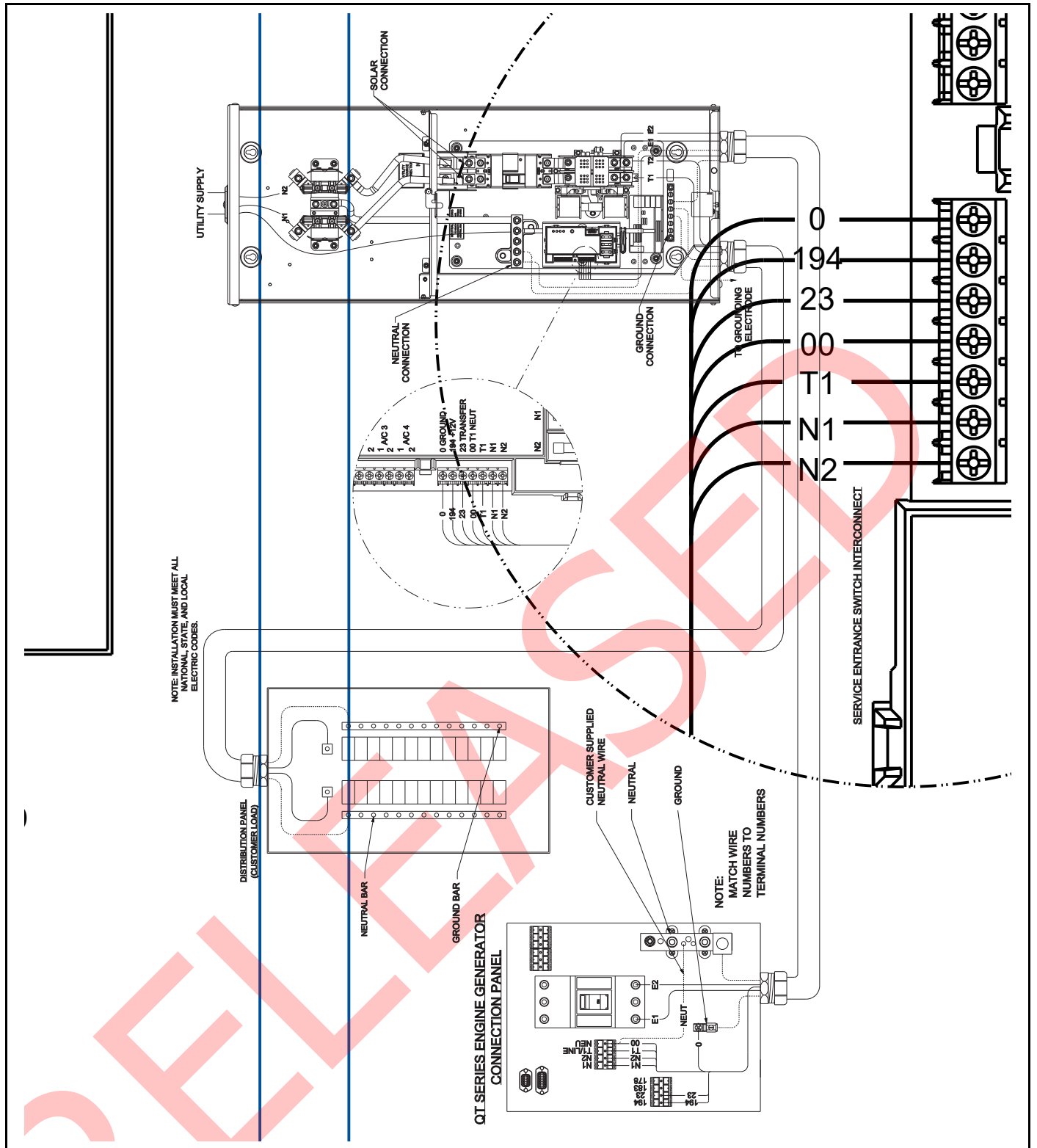

Accessory KIT 200A XFRSW W SACM G0074000

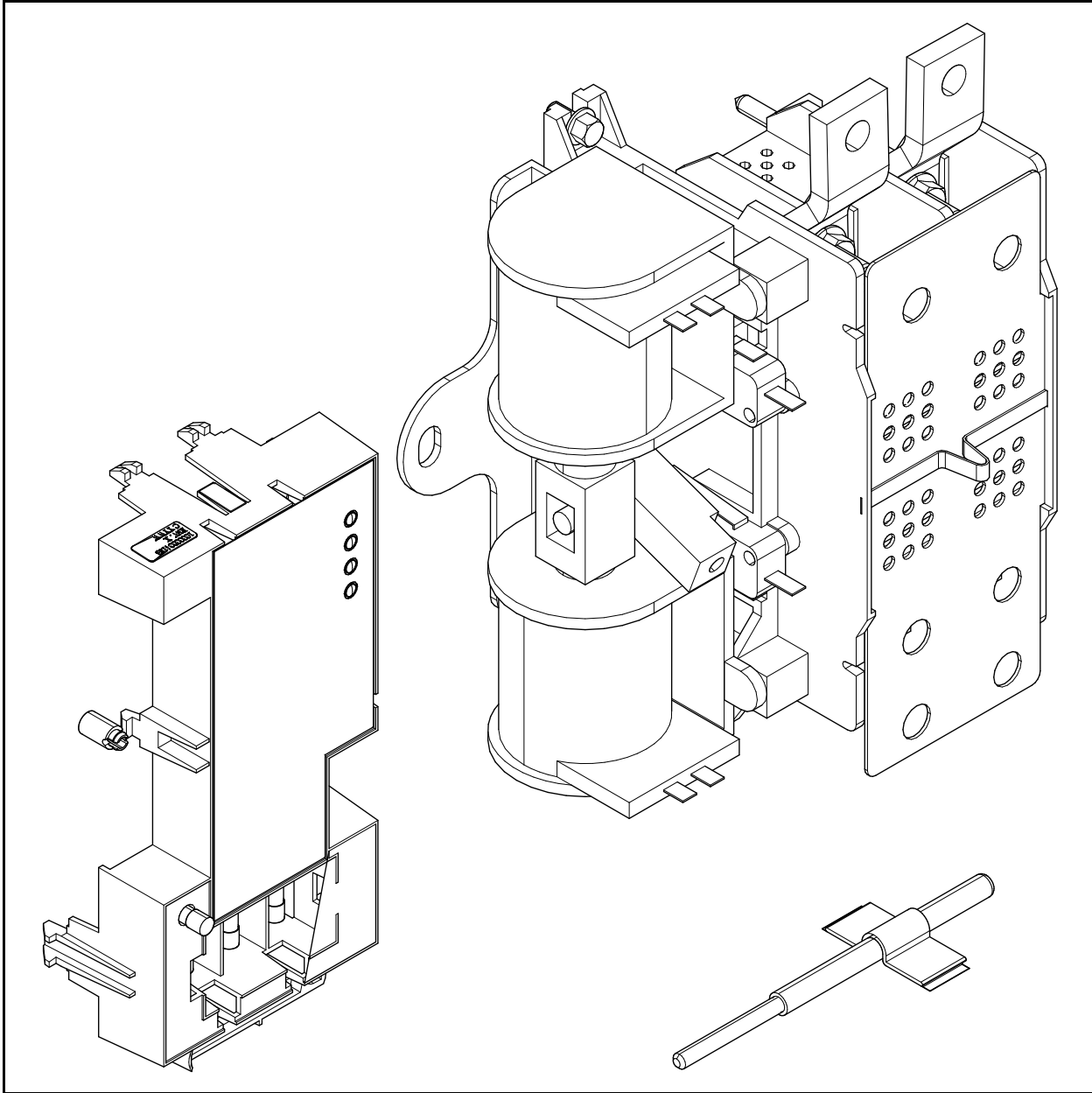

Accessory Kit ATS Ring Cover G0074010

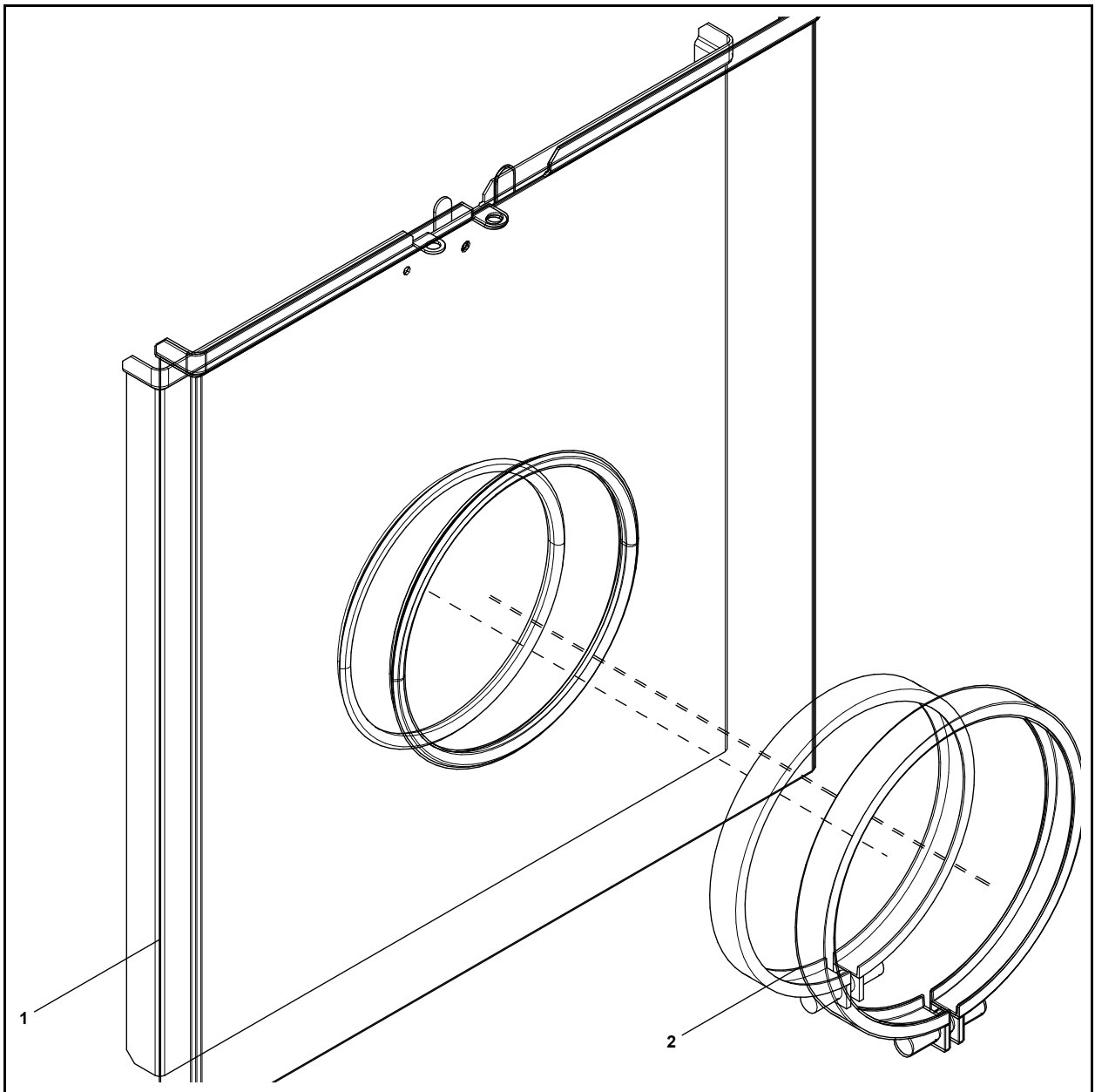

Accessory Kit Meter Jaw 5th Terminal G0074020

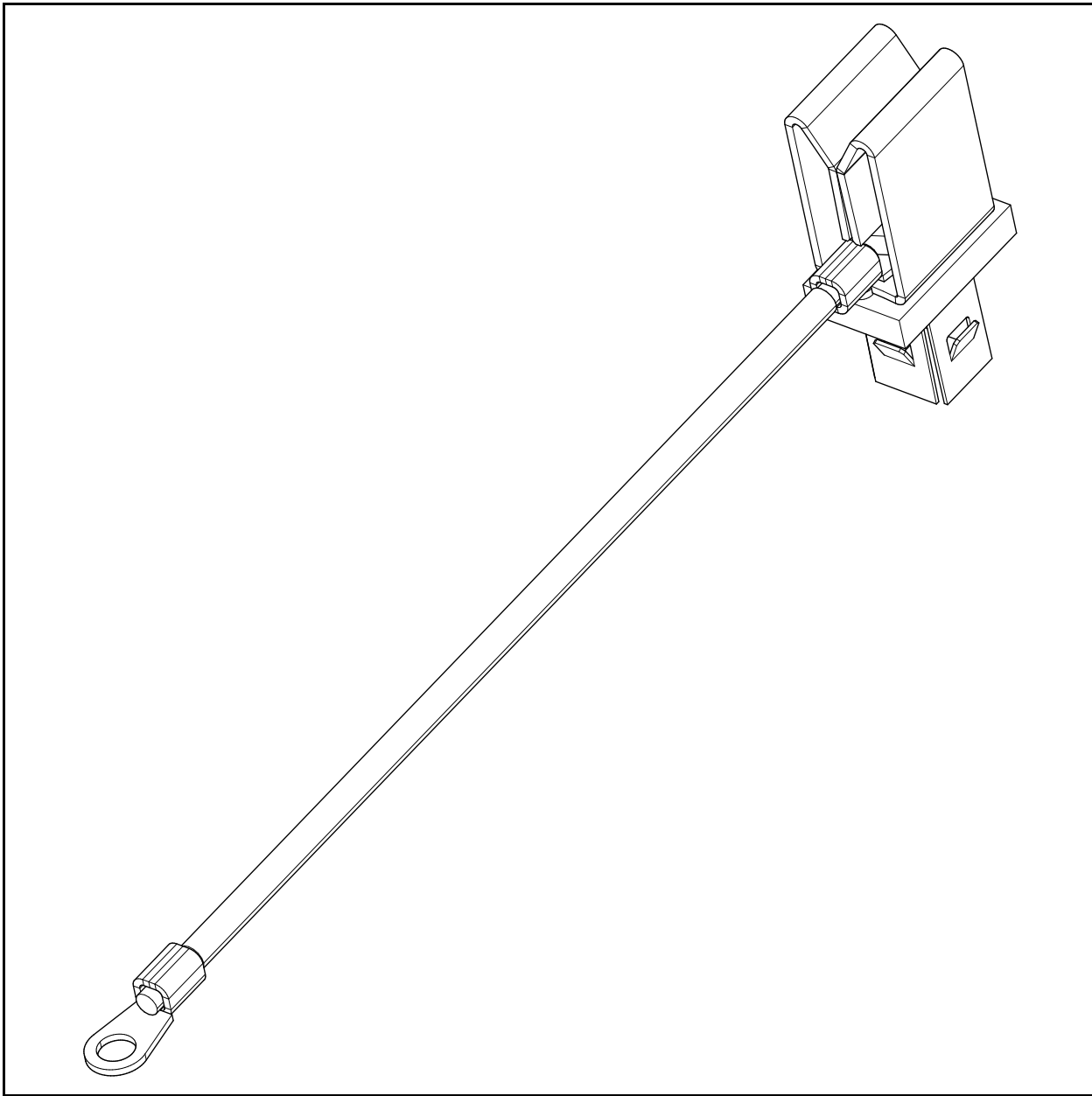

Accessory Kit Flash Shield G0074040

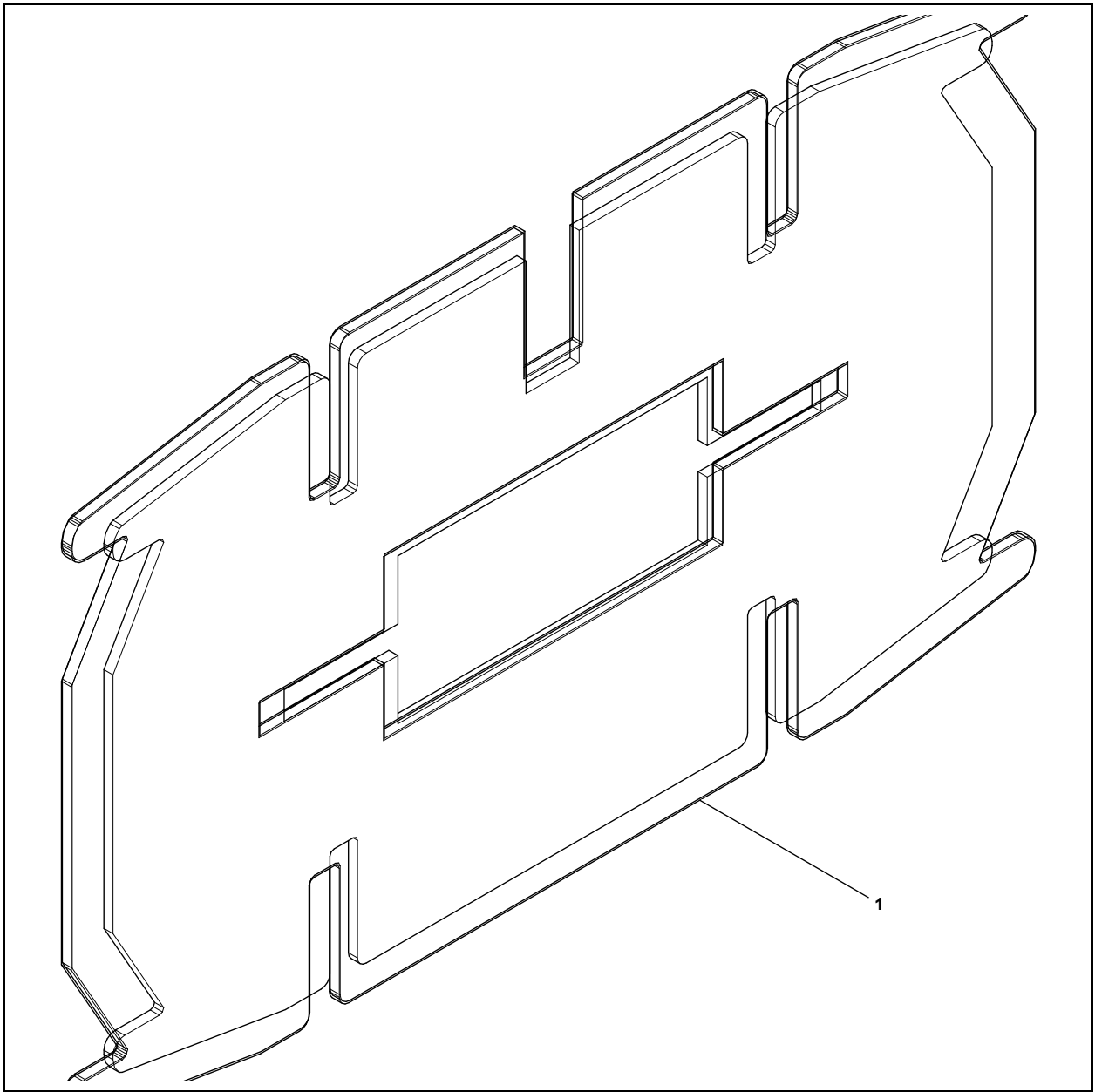

Accessory Kit Side Bus G0074050

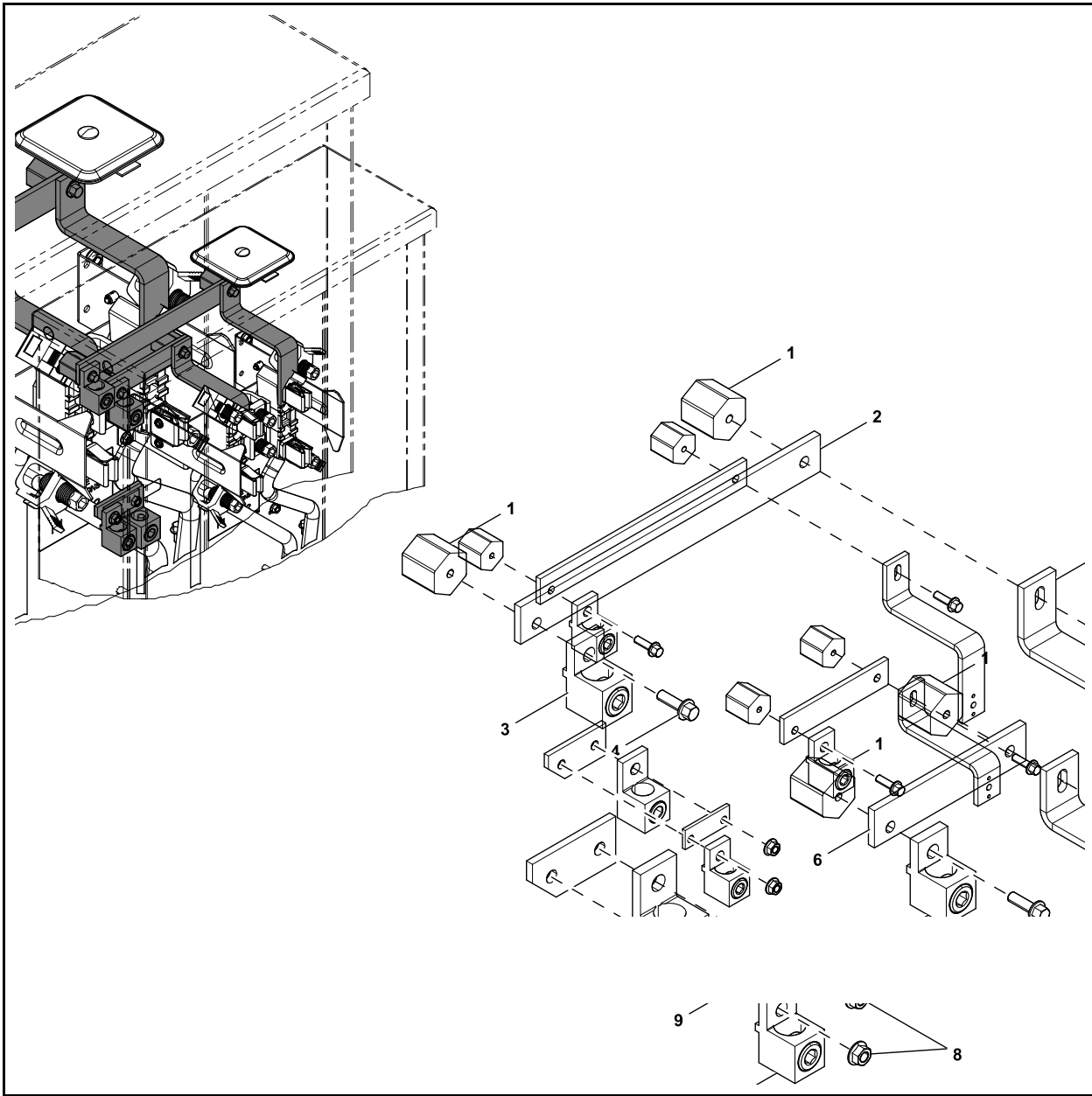

Accessory Kit Pedestal 24 in. Extension G0074060

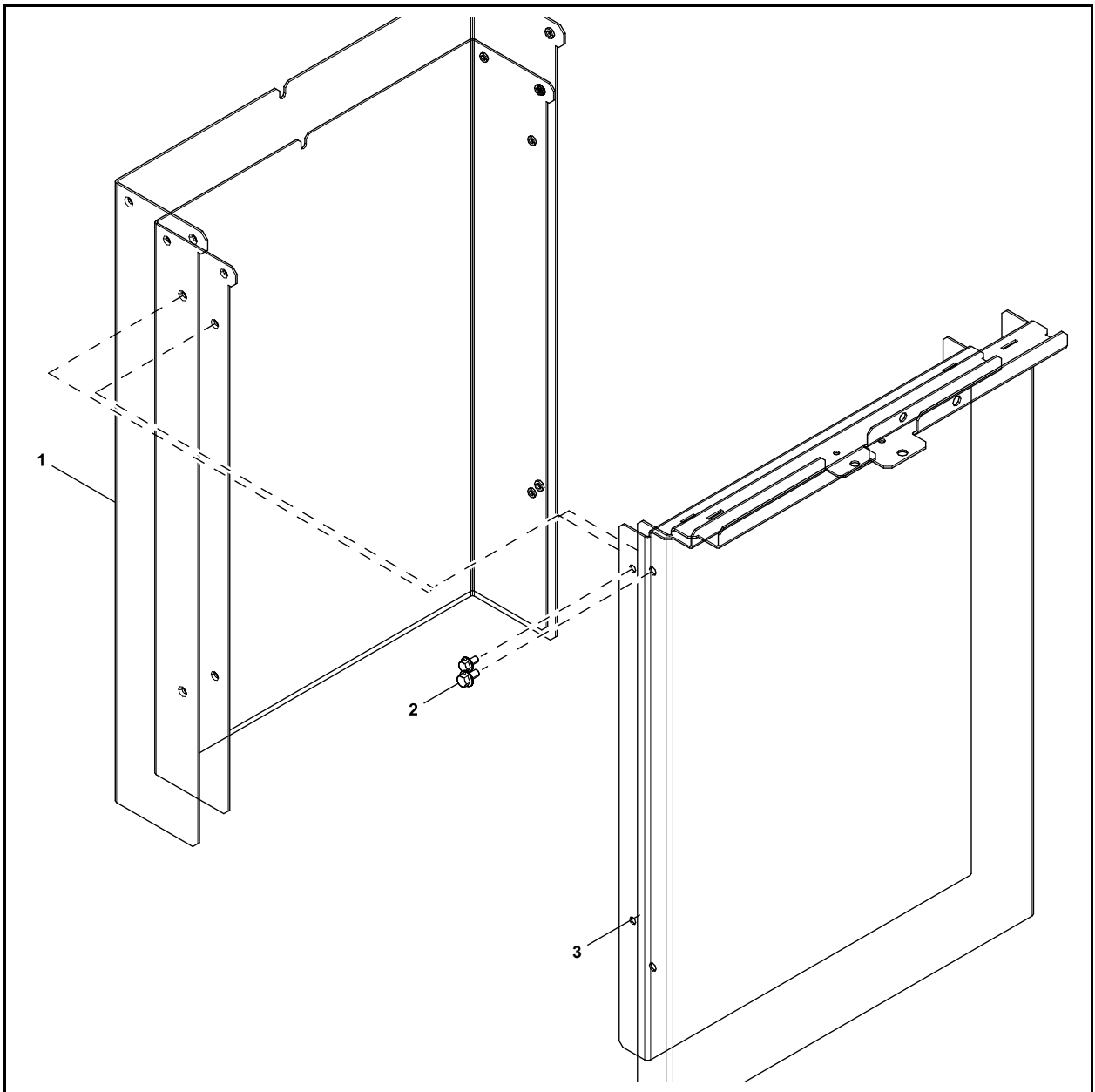

Accessory Kit Pedestal 48 in. Extension G0074070

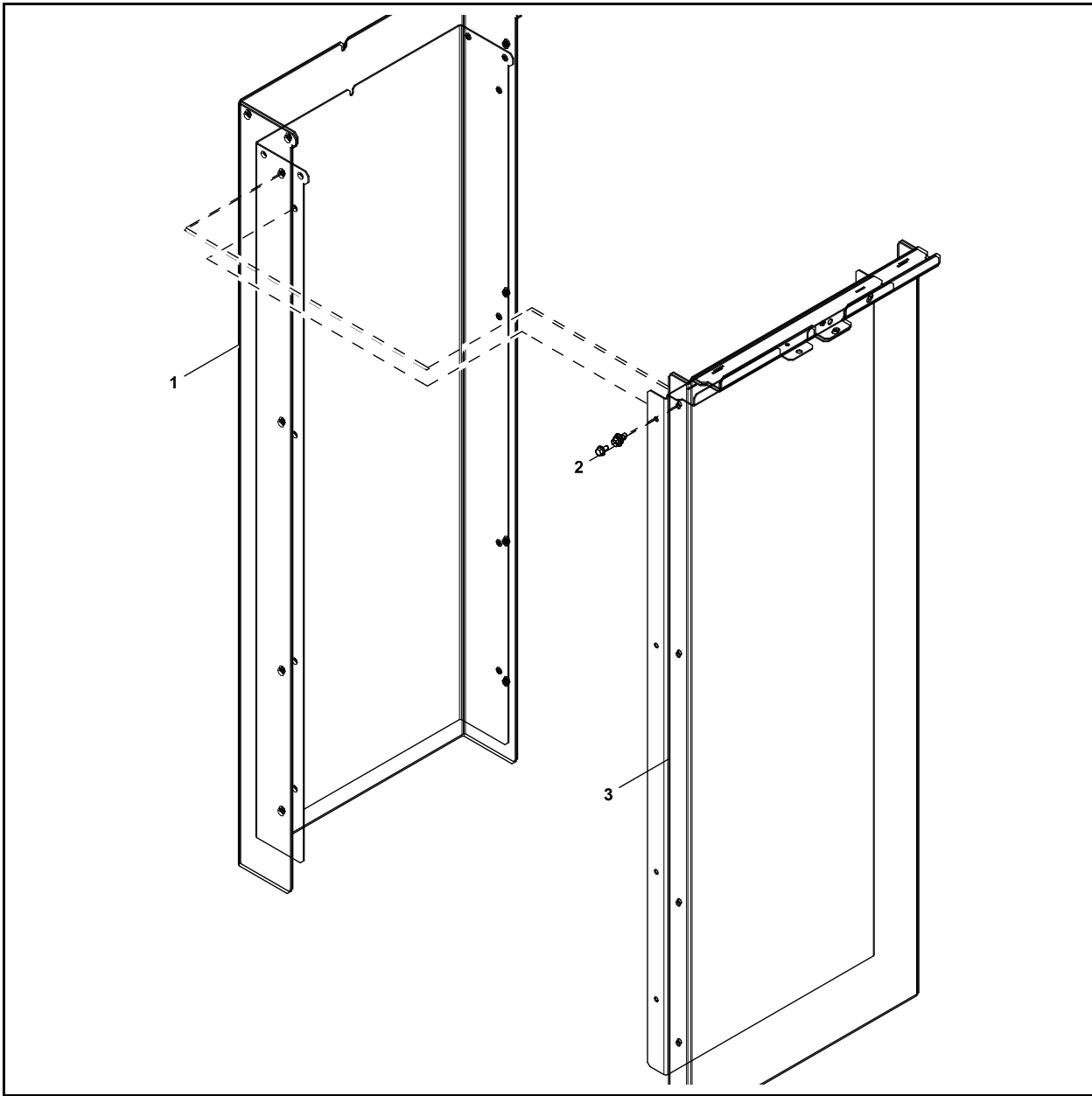

Accessory Kit ATS Ringless Cover G0074080

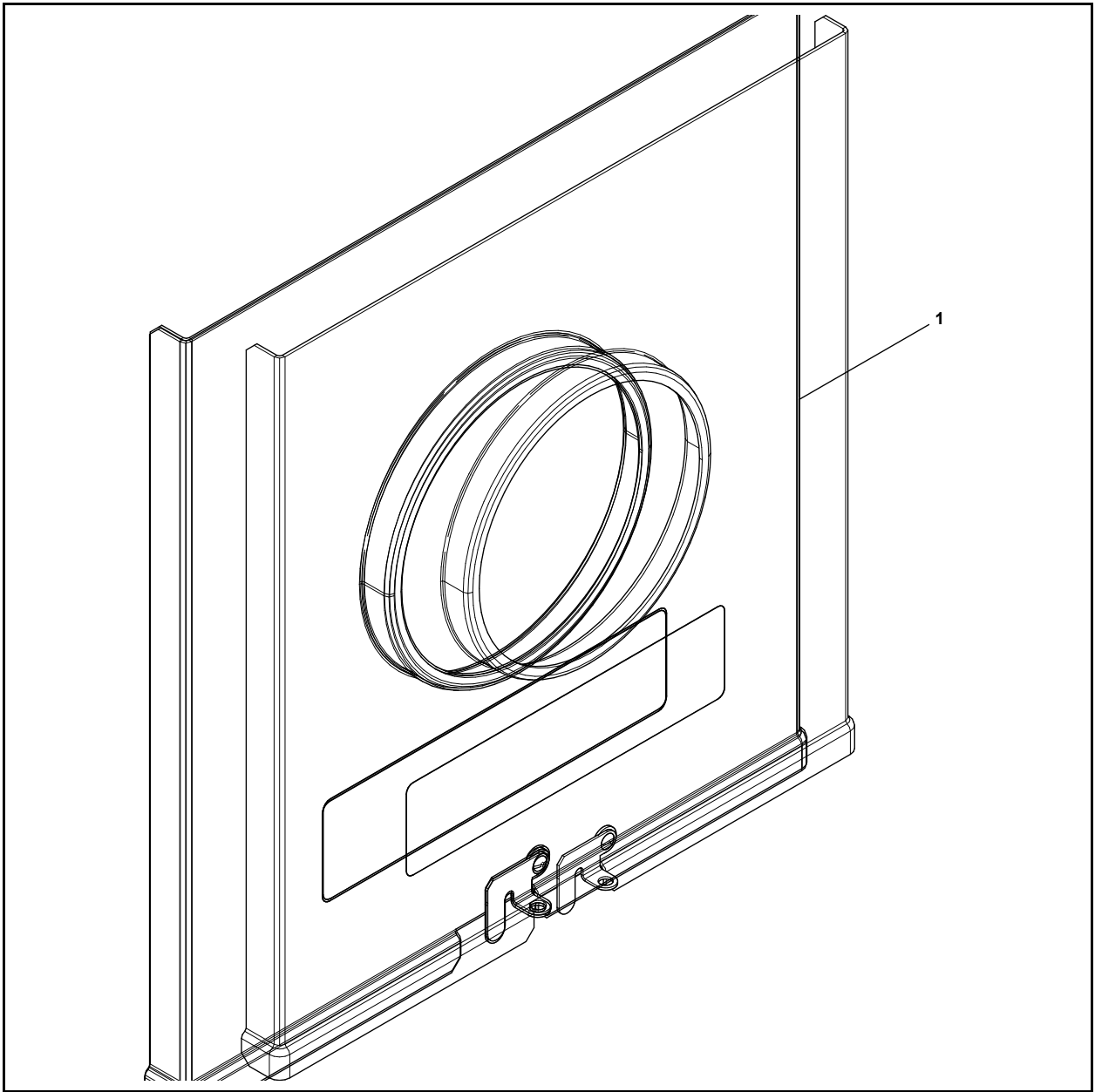

Accessory Kit Tamper Proof Upper Cover G0074100

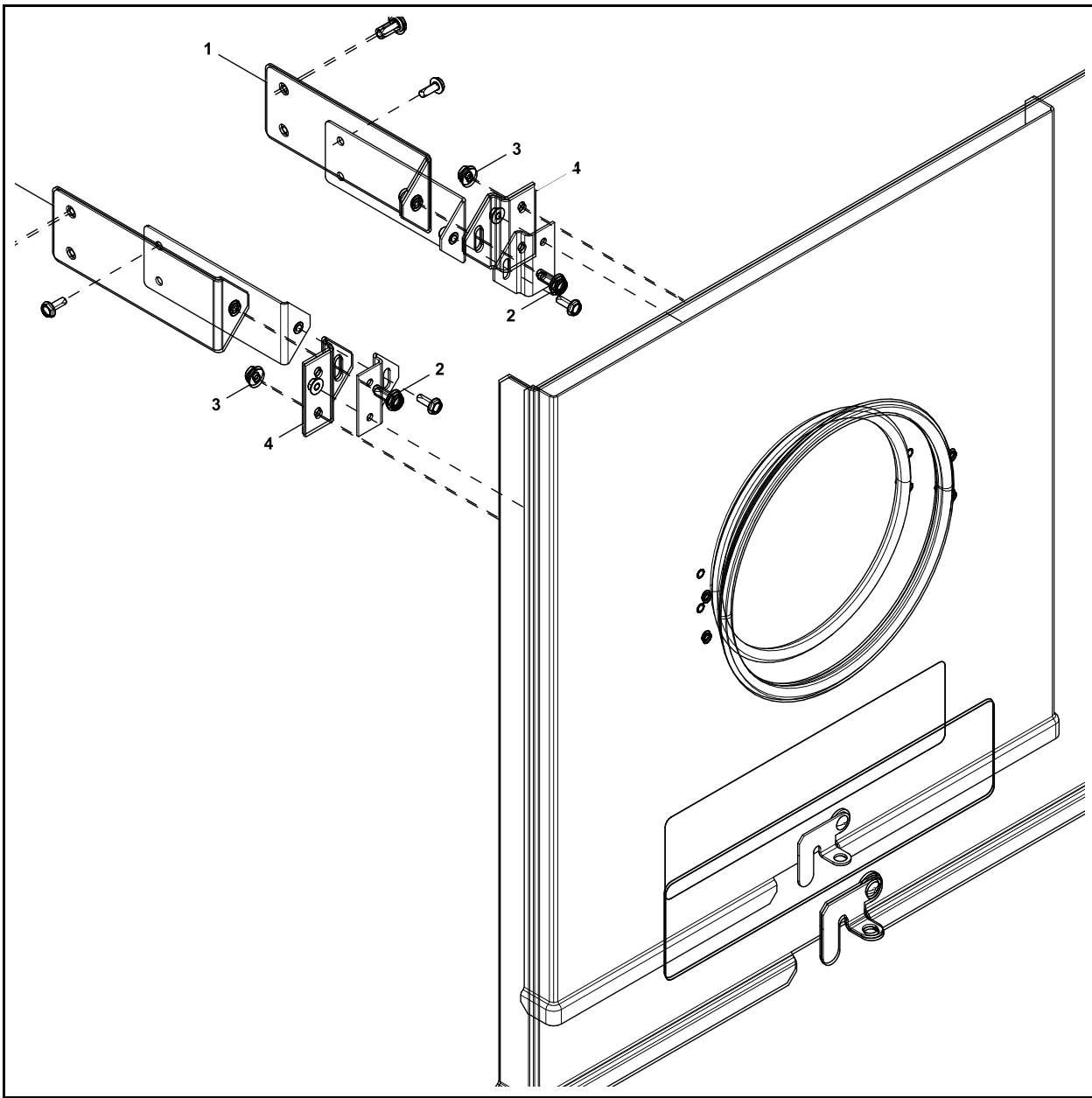

Accessory Kit Utility Barrel Lock G0074130

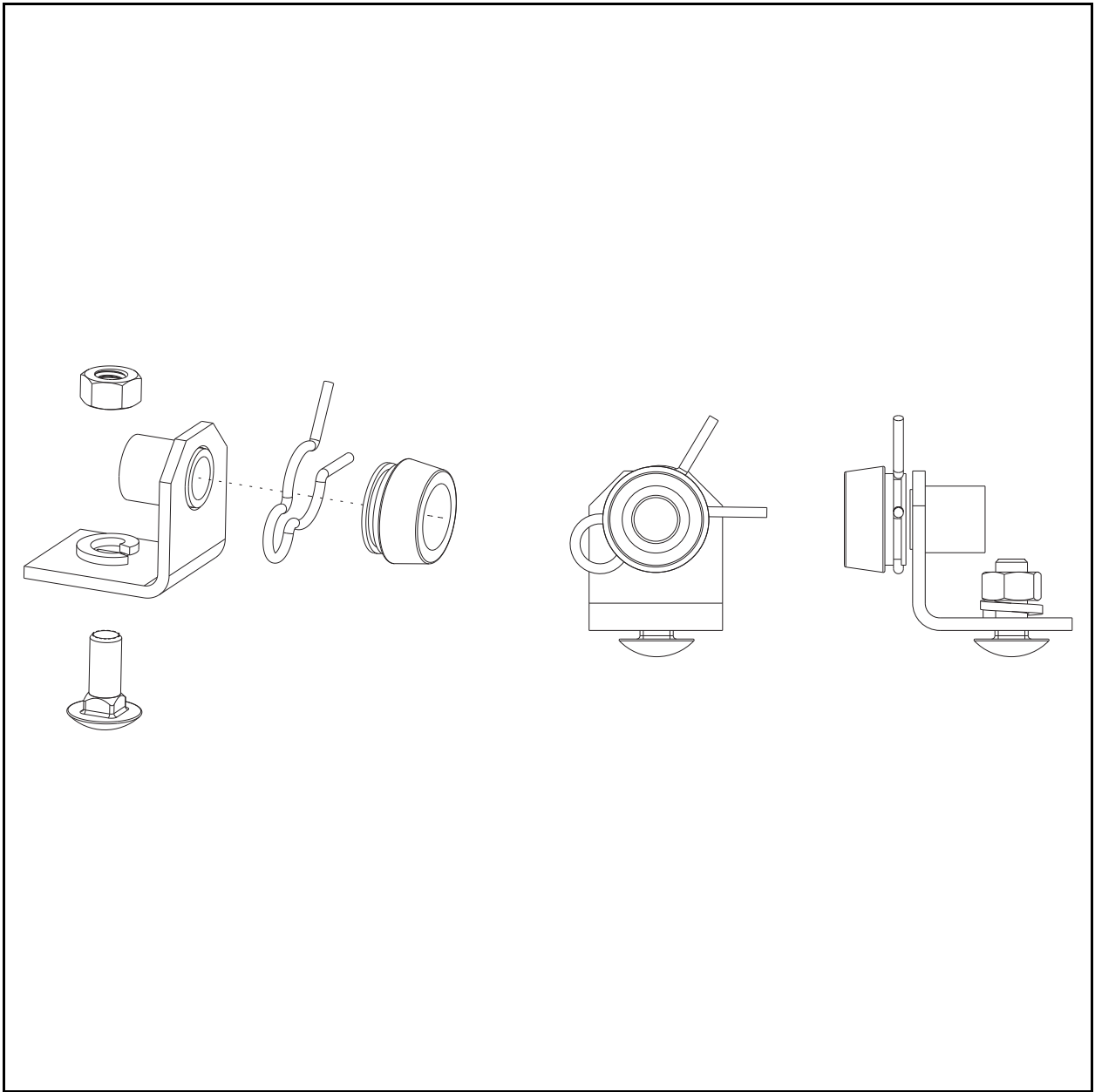

This page intentionally left blank.

Part No. A0000243082 Rev. G 2/23/2024
© 2024 Generac Power Systems, Inc.
All rights reserved
Specifications are subject to change without notice.
No reproduction allowed in any form without prior written
consent from Generac Power Systems, Inc



Generac Power Systems, Inc.
S45 W29290 Hwy. 59
Waukesha, WI 53189
1-888-GENERAC (1-888-436-3722)
www.generac.com